

Instruction Manual For Dodge® MIMA Wrapper SCXT 225 Speed Reducer

These instructions must be read thoroughly before installation or operation. This instruction manual was accurate at the time of printing. Please see dodgeindustrial.com for updated instruction manuals.

WARNING: To ensure the drive is not unexpectedly started, turn off and lock-out or tag power source before proceeding. Failure to observe these precautions could result in bodily injury.

WARNING: All products over 25 kg (55 lbs) are noted on the shipping package. Proper lifting practices are required for these products.

WARNING: Equipment being removed may be too heavy to control manually. Support it by external means. Failure to observe these precautions could result in bodily injury.

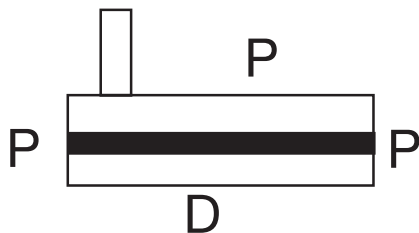

MIMA Mounting Position

WARNING: Because of the possible danger to person(s) or property from accidents which may result from the improper use of products, it is important that correct procedures be followed. Products must be used in accordance with the engineering information specified in the catalog. Proper installation, maintenance and operation procedures must be observed. The instructions in the instruction manuals must be followed. Inspections should be made as necessary to assure safe operation under prevailing conditions. Proper guards and other suitable safety devices or procedures as may be desirable or as may be specified in safety codes should be provided, and are neither provided by Dodge nor are the responsibility of Dodge. This unit and its associated equipment must be installed, adjusted and maintained by qualified personnel who are familiar with the construction and operation of all equipment in the system and the potential hazards involved. When risk to persons or property may be involved, a holding device must be an integral part of the driven equipment beyond the speed reducer output shaft.

Guidelines for Torque-Arm Reducer Long-Term Storage

During periods of long storage, or when waiting for delivery or installation of other equipment, special care should be taken to protect a gear reducer to have it ready to be in the best condition when placed in service.

By taking special precautions, problems such as seal leakage and reducer failure due to the lack of lubrication, improper lubrication quantity, or contamination can be avoided. The following precautions will protect gear reducers during periods of extended storage:

Preparation

1. Drain the oil from the unit. Add a vapor phase corrosion inhibiting oil (VCI-105 oil by Daubert Chemical Co.) in accordance with Table 4.
2. Seal the unit air tight.
3. Cover the shaft extension with a waxy rust preventative compound that will keep oxygen away from the bare metal. (Non-Rust X-110 by Daubert Chemical Co.)
4. The instruction manuals and lubrication tags are paper and must be kept dry. Either remove these documents and store them inside or cover the unit with a durable waterproof cover which will keep moisture away.
5. Protect the reducer from dust, moisture, and other contaminants by storing the unit in a dry area.
6. In a damp environment, the reducer should be packed inside a moisture-proof container or an envelope of polyethylene containing a desiccant material. If the reducer is to be stored outdoors, cover the entire exterior with a rust preventative.

When Placing the Reducer into Service

1. Clean the shaft extensions with petroleum solvents.
2. Fill the unit to the proper oil level using a recommended lubricant. The VCI oil will not affect the new lubricant.
3. Follow the installation instructions provided in this manual.

Lubrication

SCXT225MIMA Reducer is shipped with approximately 2 quarts of Mobil SHC 634 ISO 460 VG.

**Table 1- Quantities of VCI #105 Oil
Dodge Part Number 415112-80-DB**

Case Size	Quarts or Liters
SCXT2	.2 QTS.

VCI #105 & #10 are interchangeable.
VCI #105 is more readily available.

Replacement Parts

Using an arbor press, equipment for heating and shrinking bearings and gears on shafts, and the tools normally found in a maintenance department, the MIMA SCXT225 speed reducer can easily be disassembled and reassembled by careful attention to the following instructions.

Cleanliness is very important to prevent the introduction of dirt into the bearings and other parts of the reducer. The oil seals are of the rubbing type and considerable care should be exercised during disassembly or reassembly to avoid damage to the surfaces on which the seals rub. Any sharp edges on the input shaft or output hub should be covered with adhesive tape or paper before performing any work on the unit. Nicks and burrs on surfaces of the input shaft or output hub should be removed.

Ordering Parts

When ordering parts, specify SCXT225 MIMA and part number, part name, and quantity. Parts that must be pressed from shafts or output hub should be removed before ordering parts. This assures that those parts, if damaged during pressing operation, will be replaced.

It is recommended that when a pinion or gear is replaced, its mating gear or pinion be replaced also. This ensures that the gear teeth will mesh properly. If the large gear on the output hub must be replaced, it is suggested that an output hub assembly, consisting of a gear assembled on an output hub, be ordered to secure an output hub with undamaged surfaces on which the oil seals rub. However, if the old output hub is to be used, carefully press the gear and bearing cones off. Thoroughly examine the area under the oil seals for scratches or any other damage resulting from the pressing operation. To prevent oil leakage at the oil seals, the rubbing area must be smooth.

Replacements for the old oil seals should be ordered, due to the probability of these parts being damaged during disassembly.

If replacing a bearing, output hub or a shaft, it is advisable to order a set of shims for adjustment of bearings on the shaft assembly. If replacing a housing, a set of shims should be ordered for each shaft assembly because the adjustment of bearings on each shaft assembly is affected.

Disconnect any electrical power to the drive. Drain lubricant from reducer. Uncouple drive shaft and screw. Remove nuts from trough end studs. Support drive by means of hoist and carefully pull unit away from trough end to slide drive shaft out of screw.

Disassembly:

1. Position reducer on its side and remove bolts. Gently tap the output hub and input shaft with a soft hammer (rawhide not a lead hammer) to separate the housing halves. Open housing evenly to prevent damage to the parts inside
2. Lift shaft, gear and bearing assemblies from housing.
3. Remove seals, seal carriers and bearing cups from housing.
4. Clean all parts in solvent, inspect for damage and coat with oil.

WARNING: Solvents can be toxic and/or flammable. Follow manufacturer's safety procedures and directions. Failure to observe these precautions could result in bodily injury.

Reassembly:

1. **Output Hub Assembly:** Heat gear to 325° to 350°F for shrinking onto output hub. Heat bearing cones to 250° to 270°F for shrinking onto output hub.
2. **Countershaft Assembly:** Heat gear to 325° to 350°F and bearing cones to 250° to 270°F for shrinking onto shaft.
3. **Input Shaft Assembly:** Shaft and pinion are integral. Heat bearing cones to 250° to 270°F for shrinking onto shaft.
4. Drive the dowel pins back into position in the right hand housing half.
5. Install countershaft and input bearing cover in right-hand housing half. Place housing half on blocks to allow for protruding end of output hub. Install bearing cups in right-hand housing half making sure they are properly seated (output only).
6. Mesh output hub gear and small countershaft gear together and set in place in housing. Set input shaft assembly in place in the housing. Make sure bearing rollers (cones) are properly seated in their cups (output only).
7. Clean housing flange surfaces on both halves, making sure not to nick or scratch flange face. Place a new bead of gasket eliminator on flange face and spread evenly over entire flange leaving no bare spots. If too much sealant is used, it will run into the bearing, and too little sealant will result in an ineffective seal. Place other housing half into position and tap with a soft hammer (rawhide not lead hammer) until housing bolts can be used or draw housing halves together. Torque housing bolts to 550-600 in.-lb.

Place output hub seal carrier in position. Shim and torque bolts per special instructions attached.

Apply RTV to all SCAL O.D.'s.

8. Extreme care should be used when installing seals to avoid damage due to contact with any sharp edges on the input shaft or output hub. Possibility of damage and consequent oil leakage can be decreased by covering all sharp edges with tape or paper prior to seal installation. Fill cavity between seal-lips with grease. Seals should be pressed or tapped with a soft hammer evenly into place in the carrier applying pressure only on the outer edge of the seals. A slight oil leakage at the seals may be evident during initial running in but should disappear unless seals have been damaged.
9. Fill with approximately 2 quarts of Mobil SHC 634 oil, ISO 460 VG.

Modified Assembly Procedure: SCXT225 MIMA/ITW (Wrapper Units)

1. All assembly procedures for standard SCXT225 should be followed except for the following changes in shimming of output bearing.
2. New output bearing shimming procedures:
 - a. Place output bearing cup in left half of housing. Ensure the bearing cup is correctly seated.
 - b. Position output hub seal carrier (without shims) and install two carrier screws diametrically opposed.
 - c. Torque each screw to 50 in.-lb. Rotate the output hub to roll in the bearings, then torque each screw to 100 in.-lb. Rotate the output hub again to roll in the bearings.
 - d. Seat output bearings by tapping the seal carrier with a hammer; turning the output hub again to further roll in the bearings. Torque carrier bolts again to 100 in.-lb. Repeat this process of hammering, turning the output hub, and torquing to 100 in.-lb. until bearings are completely seated (3-4 seatings may be required).
 - e. With a feeler or taper gauge, measure the gap between the housing and the carrier, clockwise from and next to each screw.
 - f. To determine the required shim pack thickness, subtract 0.010 in. from the average of the two gauge readings (Pack Thickness = Gauge Average - 0.010 in.)
 - g. Remove the output hub seal carrier and install the required shims (shim pack thickness should be inspected with a 0-1" micrometer). Note: Total shim thickness per carrier should not include more than 0.009" plastic shims. All other shims should be metal, and each plastic shim should be inserted between two metal shims.
 - h. Continue with normal assembly procedure from this point. (Carrier bolt torque should be 360 in.-lb.)

Table 2 — Manufacturers' Part Numbers for Replacements

Input Shaft Bearings				
Screw Conveyor Drive Size SCXT225	Input Shaft Bearing Input Side		Input Shaft Bearing Adapter Side	
	DODGE Part Number	NSK Part Number	DODGE Part Number	NSK Part Number
	392078	BL206	392075	6305
	Countershaft Bearings			
	Countershaft Bearing Input Side		Countershaft Bearing Adapter Side	
	DODGE Part Number	NSK Part Number	DODGE Part Number	NSK Part Number
	392075	BL305	392075	BL305
	Output Hub Bearing			
	DODGE Part Number		New Departure Number	
	Cone	Cup	Cone	Cup
390812	390816	JLM710949	JLM710910	

Parts for MIMA SCXT225 Speed Reducers

Reference	Name of Part	Number Required	Part No.
1	HOUSING	1	D6653
1A	Housing Gasket ①	1	242219
2	Housing Bolt	7	411724
3	Washer	14	419199
4	Hex Nut	7	407285
5	Dowel Pin	2	420091
②	Pipe Plug	5	430031
②	Magnetic Drain Plug	1	430060
6	Countershaft Bearing Cover – Input Side	1	242212
7	Input Shaft Bearing Cover (Backstop Side)	1	354112
8	Input Shaft and Pinion 25:1 Ratio	1	242187
9	Input Shaft Key	1	443013
11	Input Shaft Bearing – Input Side ③	1	424019
12	Input Shaft Bearing – Adapter Side ③	1	424090
	COUNTERSHAFT ASSEMBLY 25:1 Ratio ④	1	392093
13	⑤ Countershaft and Pinion	1	242185
14	⑤ First Reduction Gear 25:1 Ratio	1	242005
15	⑤ Gear Key	1	242218
16	Countershaft Bearing – Input Side ③ ⑥	1	424000
17	Countershaft Bearing – Adapter Side ③	1	424000
	OUTPUT HUB ASSEMBLY ④	1	392105
18	⑤ Output Hub	1	352112
19	⑤ Output Hub Gear	1	242181
20	⑤ Output Hub Gear Key ⑦	1	443399
21	⑤ Snap Ring	1	421017
22	Output Hub Seal Carrier	1	C15035
23	Carrier Screw	4	411407
24	Carrier Screw	4	A38868
25	Lockwasher	4	419011
27	Output Hub Bearing – Cone ③	2	490812
28	Output Hub Bearing – Cup ③	2	390816
	Output Hub Shim Pack	1 Set ⑧	391059
	Output Shaft Key		
	SEAL KIT ④	1	272712
10	⑤ Input Seal	1	242211 Rubber
26	⑤ Output Hub Seal	2	352113 Steel

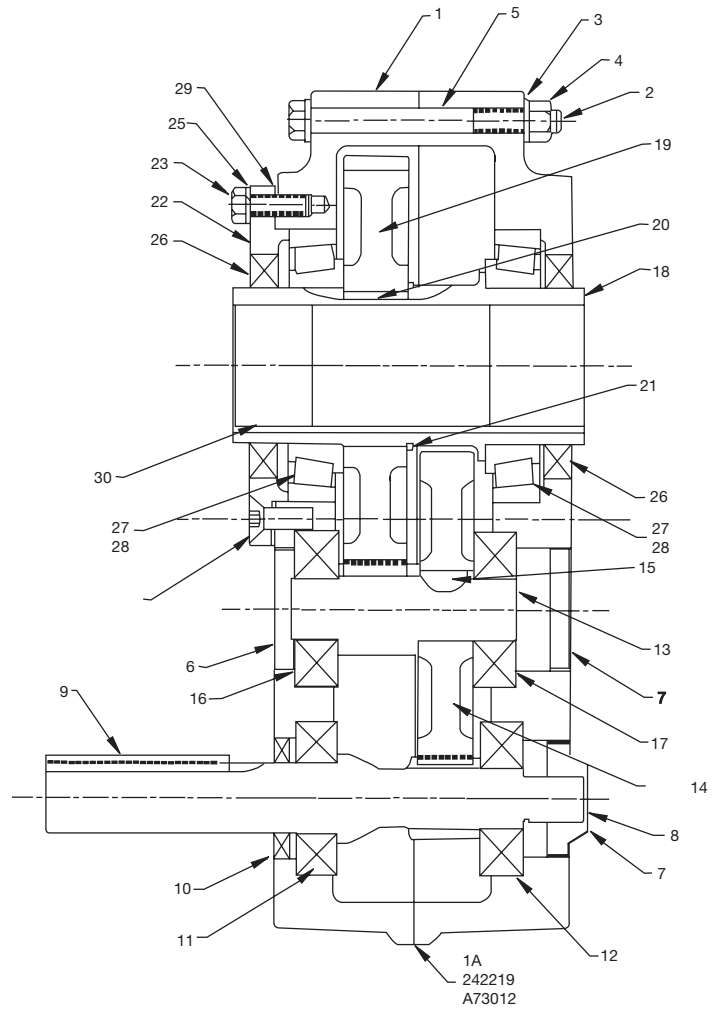

① Apply A73012 Pertmatex Form "A" Gasket 1B to both sides of housing flange with gasket

② Not shown on drawing

③ For manufacturers' part number see Table 2.

④ Recommended spare parts. Includes parts listed immediately below. Housing Assembly also includes two-piece housing

⑤ These parts make up the assemblies under which they are listed.

⑥

⑦

⑧ One set consist of one each of the shims listed immediately below

Dodge Industrial, Inc.

1061 Holland Road
Simpsonville, SC 29681
+1 864 297 4800

