



Cool Lube 2 for Sleeveoil Pillow Blocks

Part Numbers 063487, 063488, 078289, 078290

Instruction Manual

These instructions must be read thoroughly before installation or operation. This instruction manual was accurate at the time of printing. Please see dodgeindustrial.com for updated instruction manuals.

WARNING: To ensure the drive is not unexpectedly started, turn off and lock-out or tag power source before proceeding. Failure to observe these precautions could result in bodily injury.

WARNING: Only qualified personnel familiar with hydraulic and electrical installations, the construction and operation of this equipment, and the hazards involved should install, adjust, operate, and/or service it. Read and understand this manual in its entirety before proceeding. Failure to observe this precaution could result in severe bodily injury or loss of life.

SYSTEM SPECIFICATIONS

System Part Number	Motors Information	Approximate Weights (lbs)
063488	Single Phase—115/230 VAC	257
063487	Three Phase—230/460 VAC	257
078289	Three Phase—208-230/460 VAC (Explosion Proof Motors)	257
078290	Three Phase—575 VAC (Canada)	257

NOTE: For Cool Lube 2 Material Details, please refer to cut sheets.

Air to oil heat exchanger: Thermal Transfer BOL-8-2

* Pump Relief valve setting: 150 psi

* Bearing Relief valve setting: 65 psi

Pump flow rate: 2 GPM

Flow meter range: 0.5 – 4.0 GPM

Oil supply line connection: Two 1/2" NPT connections at the flow meter outlets (female)

Oil return line connection: Two 1" NPT connections (female)

* Relief valves are preset at the factory, but are field adjustable. If other settings are required, consult Dodge Engineering

WARNING: Because of the possible danger to person(s) or property from accidents which may result from the improper use of products, it is important that correct procedures be followed. Products must be used in accordance with the engineering information specified in the catalog. Proper installation, maintenance and operation procedures must be observed. The instructions in the instruction manuals must be followed. Inspections should be made as necessary to assure safe operation under prevailing conditions. Proper guards and other suitable safety devices or procedures as may be desirable or as may be specified in safety codes should be provided, and are neither provided by Dodge® nor are the responsibility of Dodge. This unit and its associated equipment must be installed, adjusted and maintained by qualified personnel who are familiar with the construction and operation of all equipment in the system and the potential hazards involved. When risk to persons or property may be involved, a holding device must be an integral part of the driven equipment beyond the speed reducer output shaft.

WARNING: All products over 25 kg (55 lbs) are noted on the shipping package. Proper lifting practices are required for these products.

RECEIVING & INSPECTION

- Carefully unpack the Cool Lube 2 system. Inspect the system for any damage during shipping.
- Report any damage to the carrier for claims.
- Make sure that available voltage supply is within 10% of the system voltage.
- Check all hydraulics to ensure that nothing came loose during shipping. Tighten as needed.
- Changes to this unit may void the warranty.



Figure 1 - Cool Lube 2

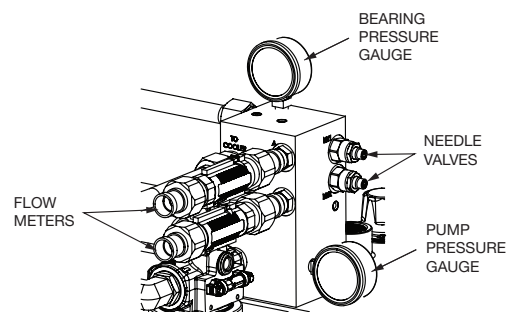

Figure 2 - Controls

INSTALLATION

- Place the unit in the designated area and anchor it down using the 4 mounting holes in the base plate. The unit should be positioned below the circulating oil drain holes in the bearings so that at least a 15° drain line slope is achieved to allow for adequate oil return (see Figure 1).
- Make sure that there is enough space around the unit to allow for servicing.
- Connect oil supply lines (not included) from the two 1/2" NPT (female) outputs of the flow meters to the circulating oil inlets on the housings. Connection details for each type of Sleeveoil bearing are provided in sections following (see Figure 2).

NOTE: All plumbing should be cleaned and flushed before being connected to the bearings.

R-Series 1-7/16" through 3-7/16"

The circulating oil inlet is a tapped hole through the plunger screw. Check Table 1 to ensure that the bearings have the correct plunger screw. If replacement is necessary, install the new plunger screw per appropriate Sleeveoil Instruction Manual.

Table 1–R-Series Oil Inlets 1-7/16" through 3-7/16"

Bore Size	Plunger Screw Modified For Circulating Oil (Part Number)
1-7/16"	422392*
1-11/16" - 1-15/16"	422393*
2-3/16"	422394*
2-7/16"	422395*
2-11/16" - 2-15/16"	422397*
3-7/16"	422398*

*Only if pillow block was manufactured prior to 1988 is new plunger screw required.

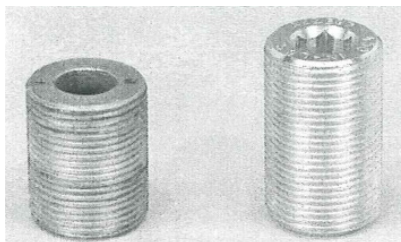

Plunger Screw Prior to 1988 – Plunger Screw 1988 to Present

Figure 3 - Plunger Screw

The user is required to provide connection adapters to connect the supply lines to the Sleeveoil circulating oil inlets (see Table 2).

Table 2–R-Series 1-7/16" through 3-7/16"

Bore Size	Number of Circulating Oil Inlets	Circulating Oil Inlet NPT Size (Female)	Circulating Oil Drain Hole NPT Size	Alternate Oil Gauge Hole NPT Size
1-7/16"	1	1/4 - 18	-	1/2 - 14
1-11/16"	1	1/4 - 18	-	1/2 - 14
1-15/16"	1	1/4 - 18	-	1/2 - 14
2-3/16"	1	1/4 - 18	-	1/2 - 14
2-7/16"	1	1/4 - 18	-	1/2 - 14
2-11/16"	1	1/4 - 18	-	1/2 - 14
2-15/16"	1	1/4 - 18	-	1/2 - 14
3-7/16"	1	1/4 - 18	1 - 11-1/2	3/4 - 14

R-Series 3-15/16" through 14"

A Circulating Oil Inlet Kit is required for each pillow block for the Cool Lube 2 installation. Install the Circulating Oil Inlet Kit as shown in the appropriate Sleeveoil Instruction Manual.

R-Series Circulating Oil Inlet Kit	Part No.
R-Series 3-15/16" Circulating Oil Inlet Kit	432153
R-Series 4-7/16" through 4-15/16" Circulating Oil Inlet Kit	430198
R-Series 5-7/16" through 12" Circulating Oil Inlet Kit	430155

The user shall provide connection adapters and Tee fittings to connect the supply lines to the circulating oil inlets. A Tee fitting is required at the inlet connection because these pillow blocks have 2 circulating oil inlets. The Tee fitting ensures both oil inlets receive an equal amount of oil. Flexible connections from the Tee fitting to the oil inlets are recommended (see Table 3 for inlet connection size).

Table 3–R-Series 3-15/16" through 14"

Bore Size	Number of Circulating Oil Inlets	Circulating Oil Inlet NPT Size (Female)	Circulating Oil Drain Hole NPT Size		Alternate Oil Gauge Hole NPT Size
			STL	SSL	
3-15/16" PLXC	2	1/4 - 18	3/4 - 14	3/4 - 14	1/2 - 14
4-7/16" PLXC	2	1/4 - 18	3/4 - 14	1 - 11-1/2	1/2 - 14
4-15/16" PLXC	2	1/4 - 18	1 - 11-1/2	1 - 11-1/2	1/2 - 14
5-7/16" PLXC	2	1/4 - 18	1 - 11-1/2	1 - 11-1/2	3/4 - 14
6" PLXC	2	1/4 - 18	1 - 11-1/2	1 - 11-1/2	3/4 - 14
7" PLXC	2	1/4 - 18	1 - 11-1/2	1 - 11-1/2	3/4 - 14
8" PLXC	2	1/4 - 18	1 - 11-1/2	1 - 11-1/2	3/4 - 14
9" PL	2	1/4 - 18	1 - 11-1/2	1 - 11-1/2	3/4 - 14
9" XC	2	1/4 - 18	1 - 11-1/2	1 - 11-1/2	3/4 - 14
10" PL	2	1/4 - 18	1 - 11-1/2	1 - 11-1/2	3/4 - 14
10" XC	2	1/4 - 18	1 - 11-1/2	1 - 11-1/2	3/4 - 14
12" PL	2	1/4 - 18	1 - 11-1/2	1 - 11-1/2	3/4 - 14
14" PL	2	1/4 - 18	1 - 11-1/2	1 - 11-1/2	3/4 - 14



Figure 4 - PLXC Circulating Oil Inlet

RTL Series

A Circulating Oil Inlet Kit is required for each pillow block for the Cool Lube 2 installation. Install the Circulating Oil Inlet Kit as shown in the Sleeveoil Instruction Manual (see Figure 5).

RTL Circulating Oil Inlet Kit	Part No.
RTL 2-15/16" thru 5-7/16" Circulating Oil Inlet Kit	132203
RTL 6" thru 12" Circulating Oil Inlet Kit	132205

The user shall provide connection adapters and tee fittings to connect the supply lines to the circulating oil inlets. A tee fitting is required at the inlet connection because these pillow blocks have 2 circulating oil inlets. The tee fitting ensures both oil inlets receive an equal amount of oil. Flexible connections from the tee fitting to the oil inlets are recommended (see Table 4 for inlet connection size).

Table 4-RTL Series

Bore Size	Number of Circulating Oil Inlets and Outlets	Circulating Oil Inlet NPT Size (Female)	Circulating Oil Drain Hole NPT Size	Alternate Oil Gauge Hole NPT Size
2-15/16"	2	3/4 - 14	1 - 11-1/2	3/4 - 14
3-7/16"	2	3/4 - 14	1 - 11-1/2	3/4 - 14
3-15/16"	2	3/4 - 14	1 - 11-1/2	3/4 - 14
4-7/16"	2	3/4 - 14	2 - 11-1/2	3/4 - 14
4-15/16"	2	3/4 - 14	2 - 11-1/2	3/4 - 14
5-7/16"	2	3/4 - 14	2 - 11-1/2	3/4 - 14
6"	2	1 - 11-1/2	2 - 11-1/2	3/4 - 14
7"	2	1 - 11-1/2	2 - 11-1/2	3/4 - 14
8"	2	1 - 11-1/2	2 - 11-1/2	3/4 - 14
9"	2	1 - 11-1/2	2 - 11-1/2	3/4 - 14
10"	2	1 - 11-1/2	2-1/2 - 8	3/4 - 14
12"	2	1 - 11-1/2	2-1/2 - 8	3/4 - 14



Figure 5 - RTL Circulating Oil Inlets

RXT Series

A Circulating Oil Inlet Kit is NOT required for these pillow blocks. The circulating oil inlets are machined into the housing and are plugged with pipe plugs as shown in the Sleeveoil Instruction Manual (see Figure 6).

The supply line should be connected to the two inlets on the downswing side of the pillow block for base loaded applications, or to the two inlets on the upswing side for cap loaded applications.

The user shall provide connection adapters and tee fittings to connect the supply lines to the Sleeveoil circulating oil inlets. A tee fitting is required at the inlet connection because these pillow blocks have 2 circulating oil inlets. The tee fitting ensures both oil inlets receive an equal amount of oil (see Table 5 for inlet connection size).

Table 5-RXT Series

Bore Size	Number of Circulating Oil Inlets	Circulating Oil Inlet NPT Size (Female)	Circulating Oil Drain Hole NPT Size	Alternate Oil Gauge Hole NPT Size
2-15/16"	2	1/2 - 14	1-1/4 - 11-1/2	1-1/4 - 11-1/2
3-7/16"	2	1/2 - 14	1-1/4 - 11-1/2	1-1/4 - 11-1/2
3-15/16"	2	1/2 - 14	2 - 11-1/2	2 - 11-1/2
4-7/16"	2	1/2 - 14	2 - 11-1/2	2 - 11-1/2
4-15/16"	2	1/2 - 14	2 - 11-1/2	2 - 11-1/2
5-7/16"	2	1/2 - 14	2 - 11-1/2	2 - 11-1/2
6"	2	3/4 - 14	2-1/2 - 8	2-1/2 - 8
7"	2	3/4 - 14	2-1/2 - 8	2-1/2 - 8
8"	2	3/4 - 14	2-1/2 - 8	2-1/2 - 8
9"	2	3/4 - 14	2-1/2 - 8	2-1/2 - 8
10"	2	1 - 11-1/2	2-1/2 - 8	2-1/2 - 8
12"	2	1 - 11-1/2	2-1/2 - 8	2-1/2 - 8

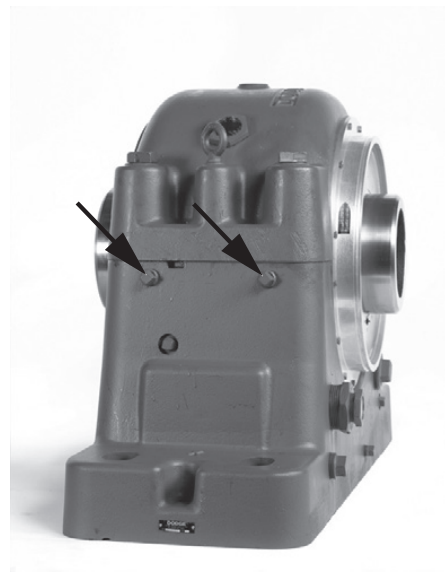

Figure 6 - RXT Circulating Oil Inlets

4. Connect oil return lines (not included) from the circulating oil drain holes in the bearing housings (not the housing drains) to the 1" NPT (female) returns on the Cool Lube 2 reservoir. Circulating oil drain hole locations are designated in the Sleeveoil Instruction Manuals. Drain hole sizes for each type of pillow block are provided in tables above.

NOTE: All housing drains for circulating oil should be used, if possible. Do not use housing drains.

NOTE: The circulating oil drain holes are positioned to maintain the proper static oil level in the housings if the circulating oil is off and the circulating oil drain holes are open. This allows the oil rings to operate and supply oil to the bearing in case the Cool Lube 2 is shut down or stops.

NOTE: Drain piping should be vented and as large as possible to drain oil from the bearings at the same rate as the incoming oil flow. The circulating oil drains must be directed straight down into a return drain sloping away at a 15° or greater angle.

5. Fill up the Cool Lube 2 reservoir by monitoring the oil level gauge on the tank. The Cool Lube 2 reservoir will hold 5 gallons of oil.
NOTE: Since the satisfactory operation of the bearing depends almost entirely on the oil film being maintained between the shaft and bearing liner surface, the use of a high quality oil from a reputable manufacturer cannot be overemphasized. Use a high grade straight mineral oil with rust and oxidation (R & O) inhibitors and antifoam agents. Check construction drawings or equipment instruction manual for proper oil. Oil viscosity is determined by the equipment manufacturer and normally specified on the construction drawing or in the operating manual.
6. Fill the bearings with oil to the recommended level (see Sleeveoil Instruction Manual).

Electrical Hook Up

Connect the two electric motors to a power supply through the proper fuses, starters and overload protection using NEC and local electrical codes.

Optional Heater/Thermostat Assembly

260W X 120V, 1 PH—Part # 434725

260W X 240V, 1 PH—Part # 434726

Optional Temperature/Oil Level Switch

Part # 434941. Connects to a control system (not provided by Dodge) in order to monitor oil level and temperature.

Replacement Filter

Use Cool Lube 2 replacement oil filter Part # 078358.

Optional Filter Additions

1. Duplex filter head with two filters
2. Water absorbing filter with moisture absorbing capability can be added in series after the standard filter.

CAUTION: This product is not be used for person moving application.

OPERATION

1. Observe the oil level gauge on the tank to ensure that oil is at the proper level.
2. Quickly jog both motors on and off to see if they are rotating in the correct directions (reference the rotation arrows on the top of the motors). Correct the wiring if necessary (reverse direction will cause damage to the pump). Before starting the Cool Lube 2, jog the pump motor four or more times to prime the pump.
3. Start the Cool Lube 2 and allow the oil to circulate. Be sure to monitor the oil level in the tank to ensure that the oil returns from the bearing housings. If air in the return lines becomes a problem, it may be necessary to bleed the air out of the lines by loosening a fitting close to where the problem is.
4. Visually check the system for leaks and correct if necessary.
5. Confirm that there is flow by using the flow meters. If there is no flow, check for leaks.
6. Adjust the oil flow rates to desired flow by adjusting the needle valves while observing the flow meters (see Figure 2). To adjust the needle valves, first loosen the locknut, then use an Allen wrench to open and close the valves. Make sure that the pump pressure does not exceed 200 psi by watching the system pressure gauge.
7. Make sure there are no leaks of any kind.
8. Turn off the pump.
9. Check oil level in the tank. The oil level will go down as the oil fills the bearing lines. If the lines are lengthy, additional oil may be needed to restore the proper level.
10. Once the flows to the bearings are confirmed, the unit is ready for operation.
11. Monitor the pressure gauges and oil level closely the first few hours of operation.
12. To change the filter while the unit is running, pull and rotate the filter bypass valve 90°.

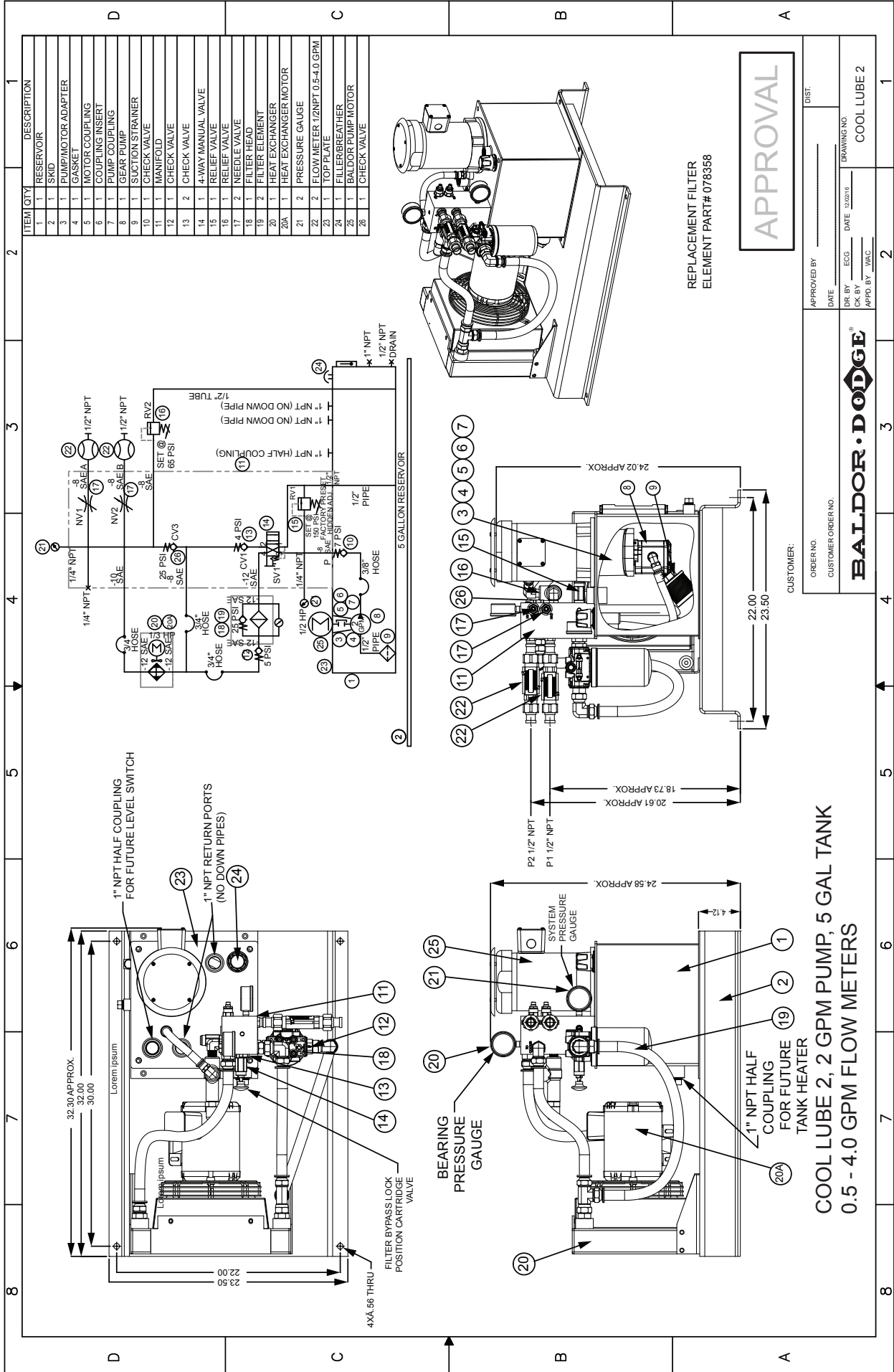

ITEM	QTY	DESCRIPTION
1	1	RESERVOIR
2	1	SKID
3	1	PUMP/MOTOR ADAPTER
4	1	GASKET
5	1	MOTOR COUPLING
6	1	COUPLING INSERT
7	1	PUMP COUPLING
8	1	GEAR PUMP
9	1	SUCTION STRAINER
10	1	CHECK VALVE
11	1	MANIFOLD
12	1	CHECK VALVE
13	2	CHECK VALVE
14	1	4-WAY MANUAL VALVE
15	1	RELIEF VALVE
16	1	RELIEF VALVE
17	2	NEEDLE VALVE
18	1	FILTER HEAD
19	2	FILTER ELEMENT
20	1	HEAT EXCHANGER
20A	1	HEAT EXCHANGER MOTOR
21	2	PRESSURE GAUGE
22	2	FLOW METER 1/2NPT 0.5-4.0 GPM
23	1	TOP PLATE
24	1	FILLER/BREATHER
25	1	BALDOR PUMP MOTOR
26	1	CHECK VALVE

APPROVED BY _____ DATE _____

DIR BY _____ ECG _____ DATE 10/20/15

CK BY _____ WAC _____

APPD BY _____

COOL LUBE 2

CUSTOMER: _____

ORDER NO. _____

CUSTOMER ORDER NO. _____

BALDOR-DODGE

APPROVED BY _____ DATE _____

DIR BY _____ ECG _____ DATE 10/20/15

CK BY _____ WAC _____

APPD BY _____

COOL LUBE 2

Hydraforce RV08-20H-0-N5/.75

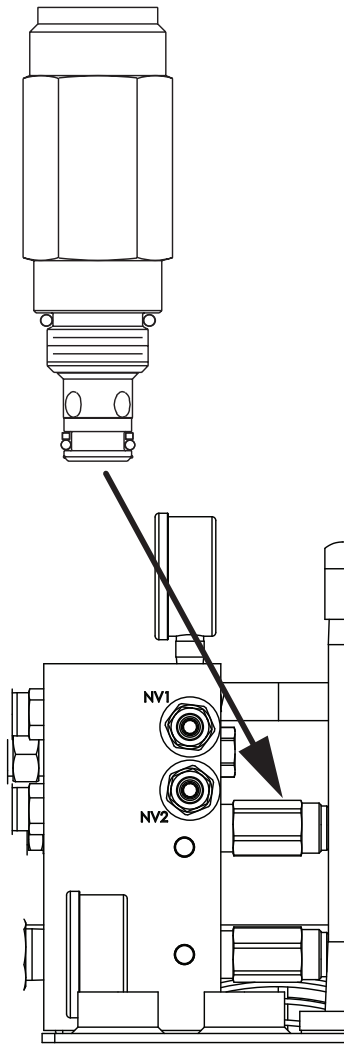

Fulflo VJ-3R/HS/WS

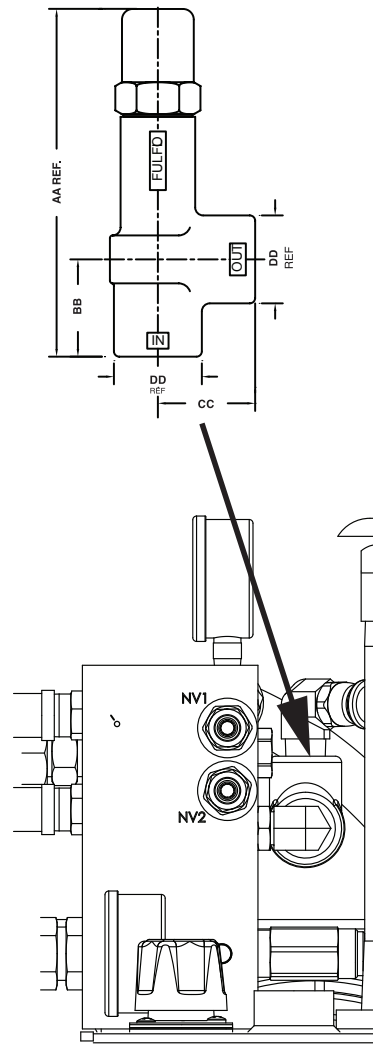

Figure 7 - Relief Valves

CAUTION: Dodge recommends the oil temperature to be 70°F or above before equipment operation.

MAINTENANCE

Periodically check the oil level in the bearing housings and the Cool Lube 2 to ensure proper operation.

Most foreign material in a system flushes to the reservoir after the first few hours of operation. We recommend that you drain the tank, replace the fluid, change the filter, and clean the suction strainer after 3-5 hours of operation. After the initial cleaning, the strainer should be cleaned at a minimum of every 4000 hours of operation. More frequent cleaning is required if the system is used in a highly contaminated atmosphere such as a foundry or paper mill.

After the initial replacement, the supply line filter should be replaced periodically as required by operating conditions. Check the visual clog indicator on the filter head between filter changes to ensure the filter is not being bypassed.

NOTE: Cool Lube 2 Units manufactured after September 2016 utilize a new relief valve for the pressure line only.

Previous Relief Valve: Hydraforce RV08-20H-0-N-5/.75

New Relief Valve: Fulflo VJ-3R/HS/WS

For Cut Sheets of each valve, contact manufacturers.

Dodge Industrial, Inc.
1061 Holland Road
Simpsonville, SC 29681
+1 864 297 4800

