

## Installation and Parts Replacement Manual For No. 188D BIO-DISC Reducer

These instructions must be read thoroughly before installation or operation. This instruction manual was accurate at the time of printing. Please see [dodgeindustrial.com](http://dodgeindustrial.com) for updated instruction manuals.

**WARNING:** To ensure the drive is not unexpectedly started, turn off and lock-out or tag power source before proceeding. Failure to observe these precautions could result in bodily injury.

**WARNING:** All products over 25 kg (55 lbs) are noted on the shipping package. Proper lifting practices are required for these products. Use supplied lifting brackets where applicable to lift reducer.

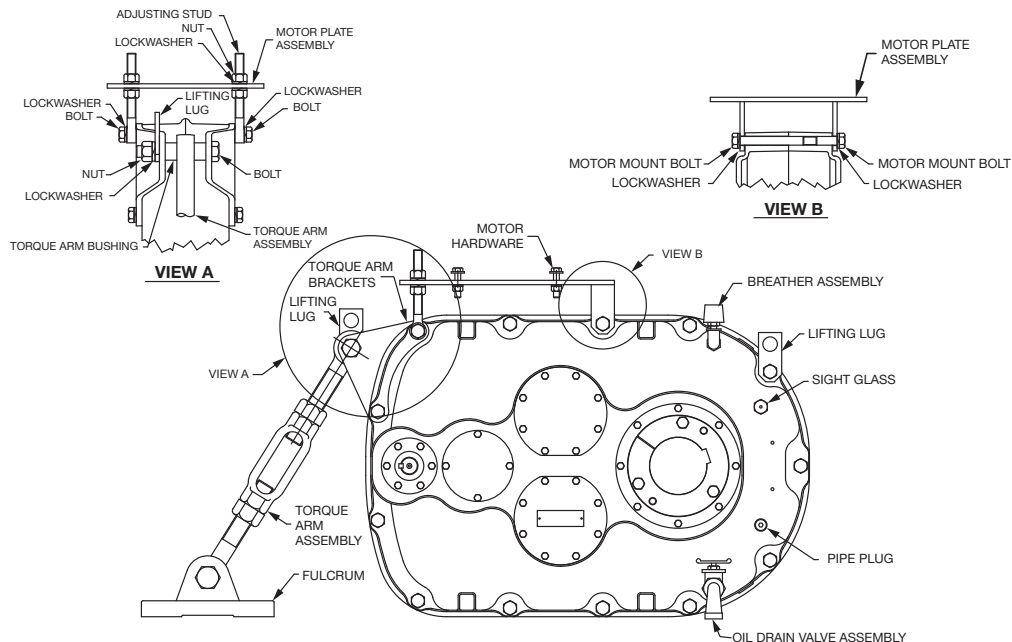

**Figure 1 - Left Hand Reducer Configuration**

**WARNING:** Because of the possible danger to person(s) or property from accidents which may result from the improper use of products, it is important that correct procedures be followed. Products must be used in accordance with the engineering information specified in the catalog. Proper installation, maintenance and operation procedures must be observed. The instructions in the instruction manuals must be followed. Inspections should be made as necessary to assure safe operation under prevailing conditions. Proper guards and other suitable safety devices or procedures as may be desirable or as may be specified in safety codes should be provided, and are neither provided by Dodge nor are the responsibility of Dodge. This unit and its associated equipment must be installed, adjusted and maintained by qualified personnel who are familiar with the construction and operation of all equipment in the system and the potential hazards involved. When risk to persons or property may be involved, a holding device must be an integral part of the driven equipment beyond the speed reducer output shaft.

The Bio-Disc reducer can be assembled for right hand or left hand configuration as shown in Figure 1 and Figure 2 below. Refer to reference below to determine proper placement of motor mount, torque arm brackets, oil drain assembly, sight gage, and breather assembly. See Table 1 for recommended bolt torques. The Bio-Disc reducer is shipped from the factory pre-filled with the proper amount of oil for horizontal installation. **If the reducer is mounted on an angle or incline, please consult Engineering for correct oil level.**

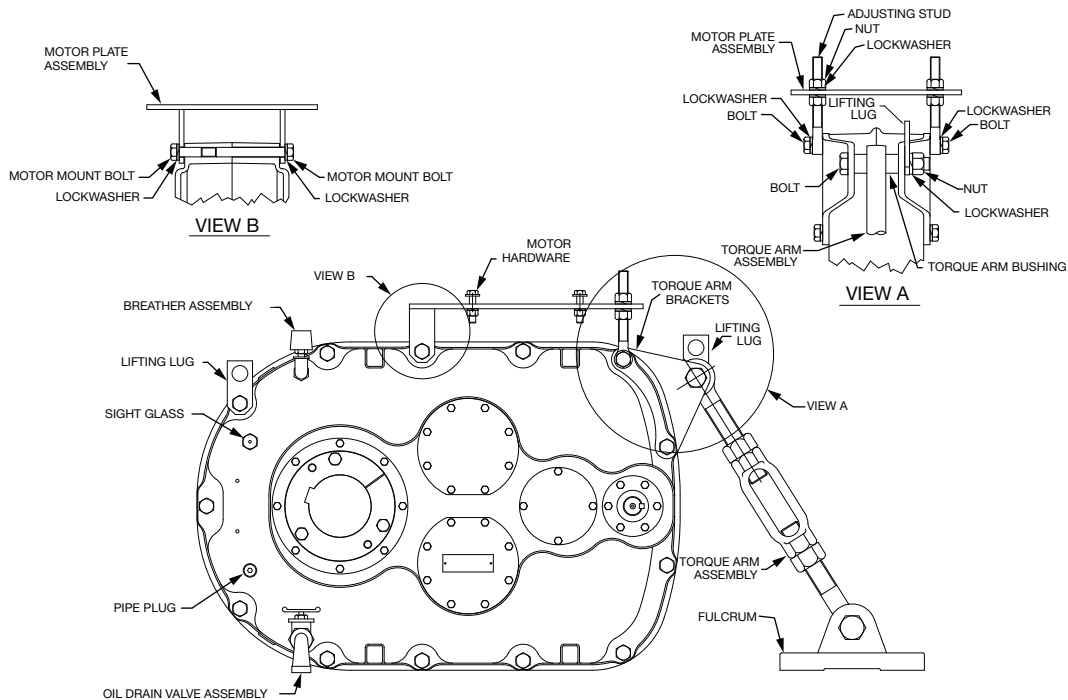

**Figure 2 - Right Hand Reducer Configuration**

## Reducer Installation

**NOTE: This reducer is compatible with the Dodge Ability Smart Sensor that can be installed in the adapter plug labelled “smart sensor”. The plug and sensor can be moved to different locations as required by mounting position.**

The Bio-Disc reducer is furnished with severe duty TDNC plated bushings to fit a 4-15/16” diameter driven shaft. Included with the reducer are two plated bushings, plated hardware, and a bushing-to-shaft key. Using proper lifting equipment, mount the reducer on the driven shaft per instructions below.

The driven shaft must extend through the full length of the reducer. The minimum shaft length, measured from the end of the shaft to the edge of the driven equipment, should be 18-1/4”. This dimension include 2-7/16” for ease of installing and removing the bushing screws. The required shaft keyseat length should be 16”.

Place one bushing, flange end first, onto the driven shaft and position 2-7/16” from the face of the driven equipment. This will allow the screws to be threaded into the bushing and for future bushing and reducer removal. If the reducer must be positioned closer to the equipment than 2-7/16”, place the screws, with washers installed, into the unthreaded holes of the bushing flange prior to placing the bushing on the shaft and position as required.

Insert the output key in the shaft and bushing. For ease of installation, rotate the driven shaft so that the shaft keyseat is at the top position.

Mount the reducer on the driven shaft and align the shaft key with the reducer hub keyway. Maintain 2-7/16” from the face of the driven equipment.

Insert the screws, with washers installed, in the unthreaded holes in the bushing flange and align with the threaded holes in the bushing backup plate. If necessary, rotate the bushing backup plate to align with the bushing screws. Tighten the screws lightly.

Place the second outer tapered bushing in position on the shaft and align the bushing keyway with the shaft key. Align the unthreaded holes in the bushing with the threaded holes in the bushing backup plate. If necessary, rotate the bushing backup plate to align with the bushing holes. Insert bushing screws, with washers installed, in the unthreaded holes in the bushing. Tighten screws lightly.

Finish tightening both tapered bushings using a two-step process. Step one, alternate and evenly tighten the screws in the inner bushing nearest the equipment to 475 lb in. Repeat the procedure on the outer bushing. Step two, alternate and evenly tighten the screws in the inner bushing nearest the equipment to 950 lb in. Repeat the procedure on the outer bushing.

## Belt Guard Installation

A universal belt guard assembly is available and can be configured as either a right hand or a left hand guard. Refer to Figure 3 for right hand universal belt guard configuration and Figure 4 for left hand universal belt guard configuration.

Using the appropriate figure below, position and attach the brackets to the belt guard back plate. Loosely tighten the brackets onto the back plate using the hardware provided. Position belt guard back plate to the reducer and loosen the appropriate reducer housing bolts. Locate the back plate to the reducer and tighten all housing bolts to 1,600 lb in. Tighten all belt guard bolts to 225 lb in.

Using the BIO DR KIT, install the large sheave on input shaft as close to the reducer as practical. Mount the motor on the adjustable motor plate assembly and install the small sheave on the motor shaft.

Install the three drive belts included in the BIO DR KIT and adjust belt tension using the motor mount adjusting nuts.

Verify belts are in-line with the reducer and motor sheaves. Do not overtighten the three drive belts.

Install the front belt guard cover with provided hardware.

Install torque arm fulcrum on a flat and rigid support so that the torque arm will be approximately at right angles to the centerline through the driven shaft and the torque arm anchor screw as shown below.

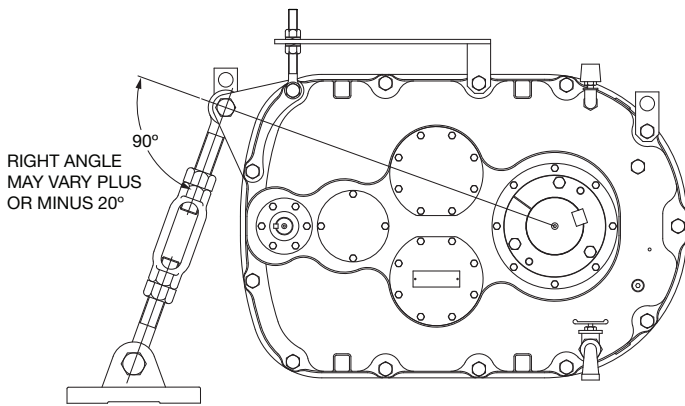

### Torque Arm Rod Angle

**CAUTION: Unit is shipped with oil however check oil level prior to operation. If reducer is installed on an angle or incline, oil may need to be added. If needed, add the proper amount of Mobil 600XP ISO 150 lubricant before operating. Failure to observe this precaution could result in damage to or destruction of the equipment.**

## BUSHING AND REDUCER REMOVAL

Remove the six (6) bushing screws.

Using the screws removed from the bushings, place two screws in the threaded holes provided in the bushing flanges. Note the two threaded holes are 180 degrees apart on the bushing flange. Tighten the screws alternately and evenly until the bushings are free on the shaft. For ease of tightening the screws, make sure the screw threads and the threaded holes in bushing flanges are clean and undamaged. If needed, a 5/8-11 UNC tap can be used to chase the bushing threaded holes.

If the reducer was positioned closer than the recommended distance to the driven equipment, loosen the inboard bushing screws until they are clear of the bushing flange by 1/8". Locate two wedges at 180 degrees between the bushing flange and the bushing backup plate. Drive the wedges alternately and evenly until the bushing is free on the shaft.

Follow the procedure above to remove the outer bushing. Once the outer bushing is removed, using proper lifting equipment, remove the reducer, the shaft key, and the inboard bushing.

## ORDERING PARTS

When ordering parts for reducer, specify reducer size number, reducer serial number, part name, part number, (where available) and quantity.

It is strongly recommended in replacing a gear that the mating gears also be replaced. Hence, for the high speed gear the input pinion and input countershaft first reduction gear should be ordered together.

For the intermediate gears, the R.H. and L.H. spiral second reduction gears and input countershaft pinion should be ordered together. And for the low speed gears, the large output gear and the two output countershaft pinions should be ordered together.

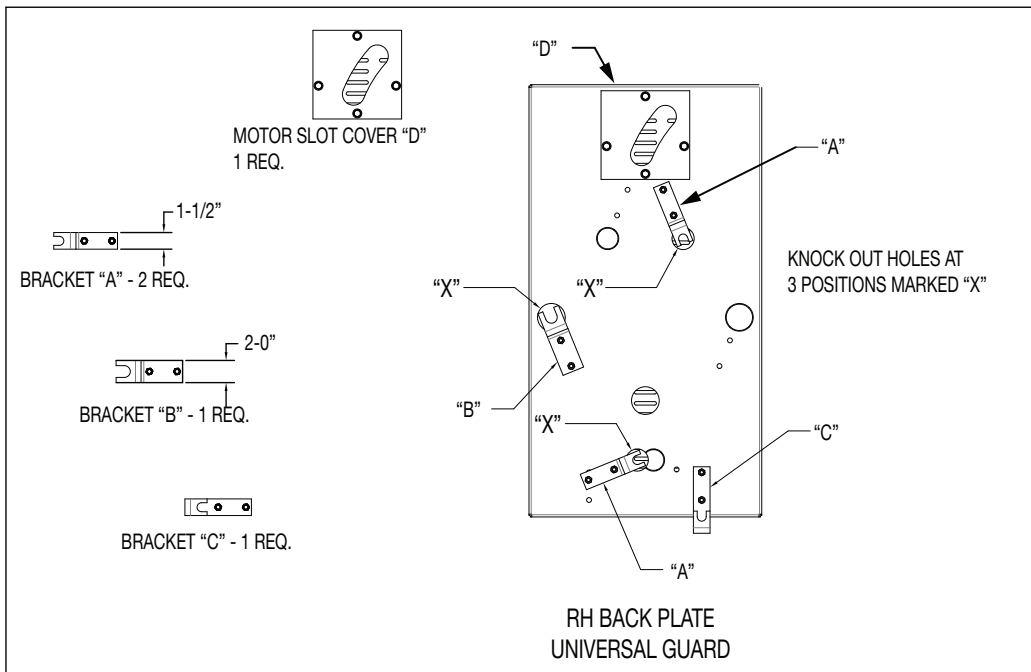
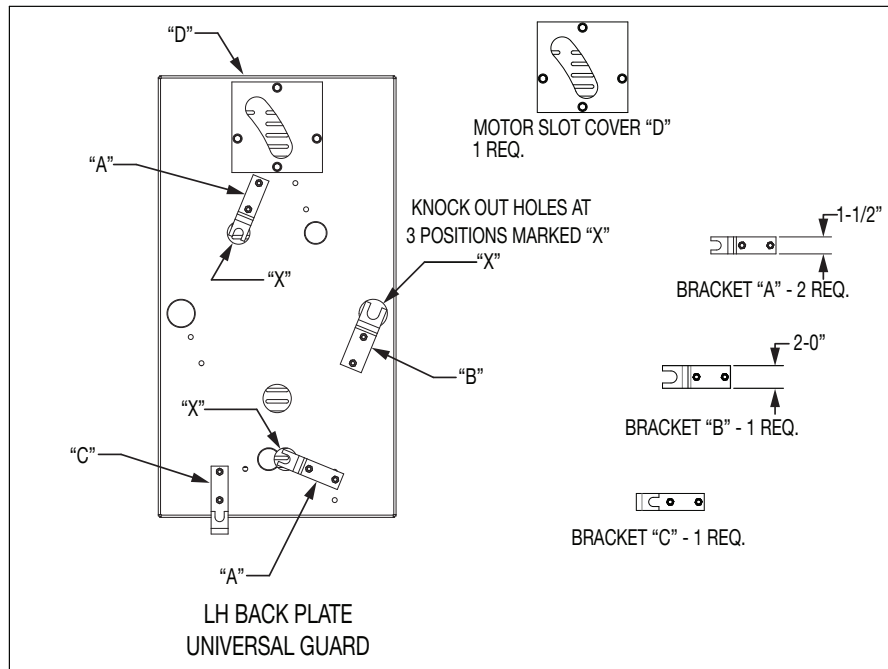

Figure 4 - Right Hand Back Plate for Universal Belt Guard



**Figure 5 - Left Hand Back Plate for Universal Belt Guard**

If the large gear on the output hub must be replaced it is recommended that an output hub assembly of a gear assembled on a hub be ordered to secure undamaged surfaces on the output hub where the oil seals rub. However, if it is desired to use the old output hub, press the gear and bearing off and examine the rubbing surface under the oil seal carefully for possible scratching or other damage resulting from the pressing operation. To prevent oil leakage at the shaft oil seals the smooth surface of the output hub must not be damaged.

If any parts must be pressed from a shaft or from the output hub, it should be done before ordering parts to make sure that none of the parts are damaged in removal.

Because old shaft oil seals may be damaged in disassembly it is advisable to order replacements for these parts.

If replacing a bearing or a shaft it is advisable to order a set of shims for adjustment of the bearing in the shaft assembly. If replacing the housing it is advisable to order a set of shims for each shaft assembly because the adjustment of the bearings in each shaft assembly is affected.

## REPLACEMENT OF PARTS

Using tools normally found in a maintenance department, a Dodge TORQUE-ARM reducer can be disassembled and reassembled by careful attention to the instruction.

Cleanliness is very important to prevent the introduction of dirt into the bearings and other parts of the reducer. A tank of clean solvent, an arbor press, and equipment for heating bearings and gears, should be available for shrinking these parts on shafts.

The oil seals are of the rubbing type and considerable care should be used during disassembly and reassembly to avoid damage to the surface which the seals rub on.

The keyseat in the input shaft as well as any sharp edges on the output hub should be covered with scotch tape or paper before disassembly or reassembly. Also be careful to remove any burrs or nicks on surfaces of input shaft and output hub before disassembly or reassembly.

## LUBRICATION INSTRUCTIONS

NOTE: Reducer is shipped with oil. With sight gauge installed, verify correct oil level prior to operation. If reducer is installed on an angle or incline, oil may need to be added. If needed, add the proper amount of Mobil 600XP ISO 150 lubricant before operating. Failure to observe this precaution could result in damage to or destruction of the equipment.

When changing oil use a Mobil 600XP ISO 150 lubricant or an equivalent high grade petroleum-base, rust and oxidation inhibited (R & O) gear oil. See table below for guidelines. Follow instructions on reducer nameplate, warning tags and installation manual.

Oil Recommendations for Average Operating Conditions			
Ratio and Output RPM	Room Temp. °Fahrenheit	Oil	
		ISO VG	AGMA Number
170:1-1.5 rpm	0° to 100°	150	4
	101° to 125°	220	5

Under average industrial operating conditions, the lubricant should be changed every year. Intermittent operation requires increased maintenance at which time lubricant should be changed every 2500 hours of operation or every 6 months, whichever occurs first. Drain reducer and flush with kerosene, clean magnetic drain plug and then refill unit to proper level with new lubricant. Mounting position may vary up to +/- 15 degrees on a horizontal shaft without modifying the standard oil fill of 45 quarts. If installing the reducer on an incline, contact Dodge Engineering for the correct oil fill.

**CAUTION: Too much oil will cause overheating and too little will result in gear failure. Check oil level regularly.**

Extreme pressure (EP) lubricants are not recommended for average operating conditions.

Pour point of lubricant selected should be at least 10° F. lower than expected minimum ambient starting temperature.

**NOTE: Horizontal Oil Level Capacity - Approximately 45 quarts. If the reducer is mounted on an angle or incline, please consult Dodge Engineering for correct oil level.**

## Recommended Bolt Torque

Table 1 - Bio-Disc Recommended Bolt Torque

Bolt Location	Fastener Size	Torque (lb in)
Belt Guard Bracket Bolts	3/8-16	225
Tapered Bushings	5/8-11	950
Motor Mount to Housing	3/4-10	1600
Housing Bolts	3/4-10	1600
TA Bracket to Housing	3/4-10	1600

**Parts for Number 188D Bio-Disc Reducer**

Reference	Name of Part	Number Required	Part Number
2	HOUSING ASSEMBLY ②	1	021835
①	③ Air Vent ④	1	964366
6	③ Housing Bolt ⑤	12	411542
8	③ Adapter/Motor Mount - Housing Bolt ⑤	1	411499
10	③ Adapter/Motor Mount Bolt ⑥	2	411268
12	③ Adapter/Motor Mount Bolt ⑥	1	411496
14	③ Lockwasher	16	419016
①	③ Plain Washer	2	034017020AB
①	③ Dowel Pin	2	420132
16	③ Pipe Plug	2	430035
①	③ Smart Sensor Adapter	1	966907
①	③ Magnetic Plug	1	430064
22	Input Shaft Seal Carrier	1	021769
23	Input Shaft Bearing Shim Pack	2 sets ⑦	389921
24	Carrier and Cover Screws	34	032018010CJ
25	Lockwasher	34	419011
26	Input Shaft with Pinion	1	259162
28	Input Shaft Key	1	443053
30	Input Shaft Seal	1	021771
①	Input Shaft V-Ring	1	905261
	Input Shaft Bearing - Left Side	1	
32	Cone	1	402275
33	Cup	1	403103
	Input Shaft Bearing - Right Side	1	
34	Cone	1	402276
35	Cup	2	403103
125	Output Seal Wear Sleeve		390000
	INPUT COUNTERSHAFT ASSEMBLY ②	1	
36	③ Countershaft with Pinion (R.H.)	1	021761
38	③ First Reduction Gear	1	021762
40	③ Gear Key	1	443385
42	③ Countershaft Pinion (L.H.)	1	021760
44	③ Pinion Key	1	443386
46	Input Countershaft Spacer	2	021834
48	Retaining Ring	1	421005
50	Input Countershaft Bearing	2	424233
52	Retaining Ring	3	421032
54	Input Countershaft Cover - Left Side	1	021767
	OUTPUT COUNTERSHAFT ASSEMBLY		
	Left-Hand Spiral ②	1	
56	③ Countershaft with Pinion	1	021759
57	③ L.H. Spiral Second Reduction Gear	1	249005
58	③ Key	2	301491
	Right-Hand Spiral ②	1	
56	③ Countershaft with Pinion	1	021759
60	③ R.H. Spiral Second Reduction Gear	1	021763
58	③ Key	2	248218
	Output Countershaft Bearing		
	Cone	4	402109
	Cup	4	403078
64	Output Countershaft Cover - Right Side	2	247224
66	Output Countershaft Cover - Left Side (R.H.)	1	021765
68	Output Countershaft Cover - Left Side (R.H.)	1	021791
	Output Countershaft Bearing Shim Pack	4 sets ⑦	389922
	OUTPUT HUB ASSEMBLY ②	1	
70	③ Output Hub	1	021757
72	③ Output Gear	1	021764
74	③ Key	2	443387

**Parts for Number 188D Bio-Disc Reducer**

Reference	Name of Part	Number Required	Part Number
76	Bushing Back-Up Plate	2	272082HD
78	Retaining Ring	2	421097HD
80	Output Hub Seal	2	021733
82	Output Hub Seal Carrier	1	249221
84	Output Hub Spacer Output	1	021772
	Output Hub Bearing		
86	Cone	2	402160
87	Cup	2	403110
88	Output Hub Bearing Shim Pack Seal	1 set ⑦	249139
125	Wear Sleeve (s)	⑦	390000
	BUSHING ASSEMBLY ②	1	021832DNC
89	③ Bushing	2	272080
90	③ Bushing Screw	6	032018016EK
91	③ Lockwasher	6	034017018AB
①	③ Key Bushing to Shaft	1	443388
	TORQUE-ARM ASSEMBLY ②		
92	③ Rod End	1	021837
94	③ Hex Nut	1	407107
96	③ Turnbuckle	1	272447
98	③ Extension	1	021838
99	③ Hex Nut	1	965051
100	③ Fulcrum	1	272445
102	③ Fulcrum Screw	1	411303
104	③ Lockwasher	1	03401728AB
106	③ Hex Nut	1	407103
108	Adapter Plate	2	249241P
110	Adapter Bushing	1	021785
112	Adapter Bolt	1	411532
114	Lockwasher	1	419141
116	Hex Nut	1	407101
118	Motor Mount Base Plate Assembly	1	259163
120	Rod End	2	021788
122	Plain Washer	4	419082
124	Hex Nut	4	407095

① Not shown on drawing

② Includes parts listed immediately below

③ These parts make up the assemblies under which they are listed

④ Includes bushing and elbow

⑤ Bolts are located on Left Housing half

⑥ Bolts are located on Right Housing half

⑦ If replacing a bearing or a shaft It is advisable to order a set of shims for adjustment of the bearing in the shaft assembly. If replacing the housing it is advisable to order a set of shims for each shaft assembly because the adjustment of the bearings in each shaft assembly is affected.

# Parts for No. 188D Bio-Disc Reducer

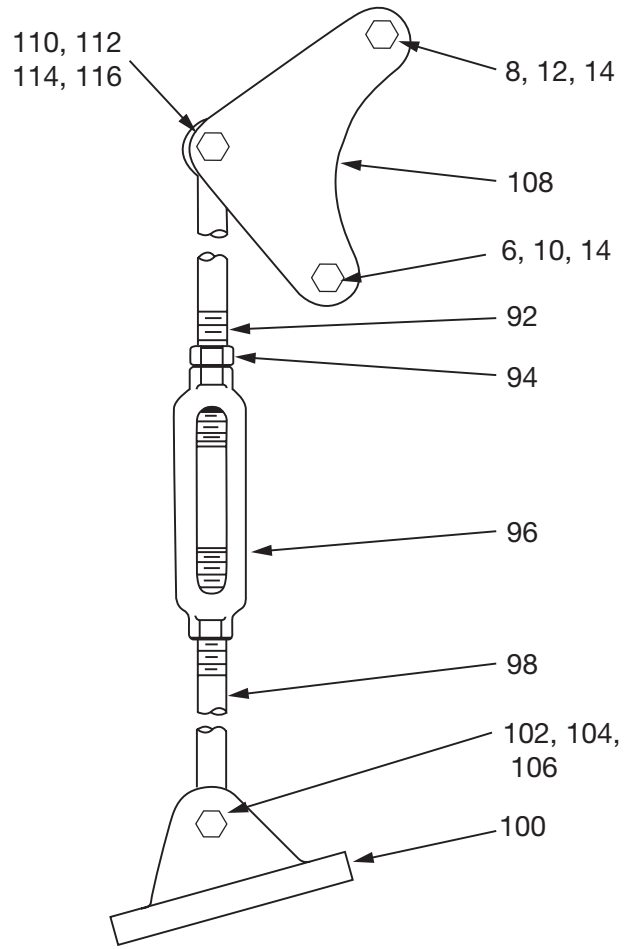
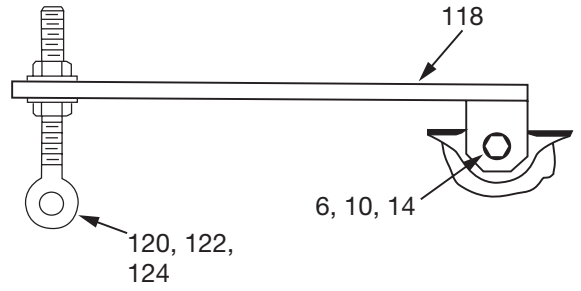
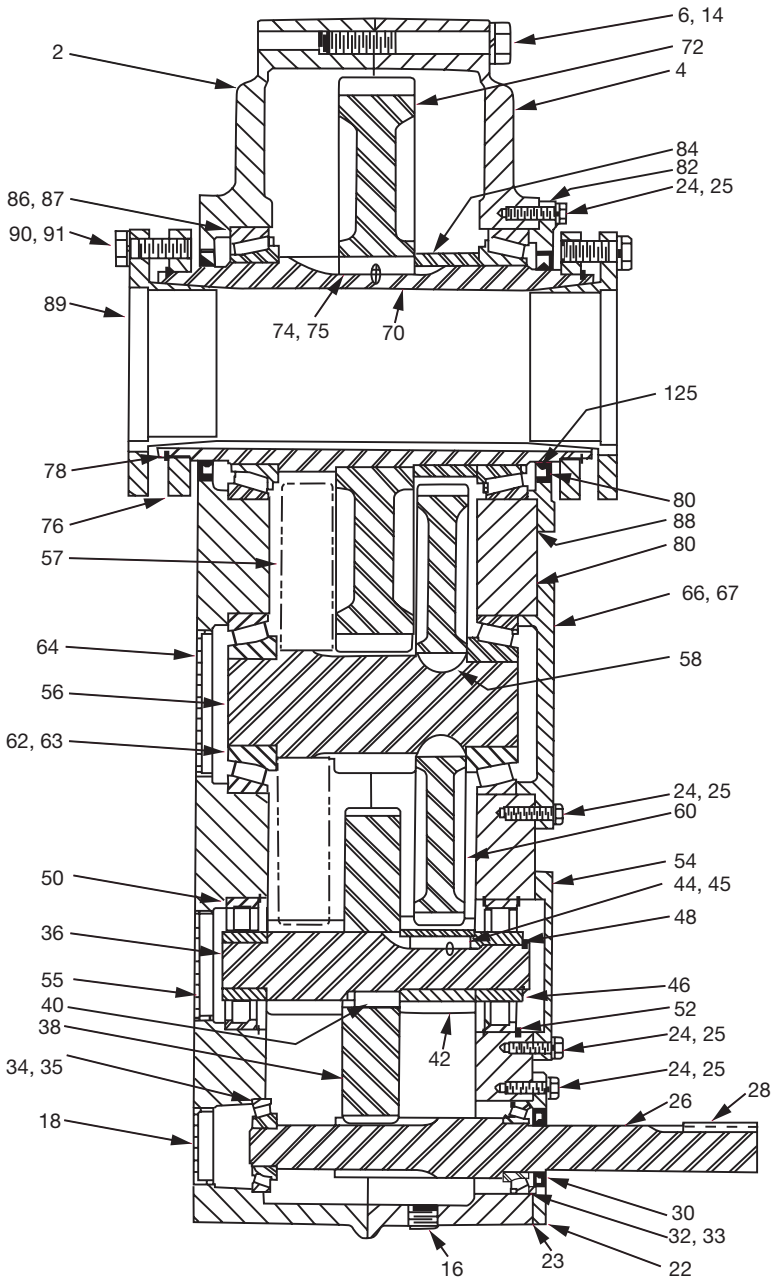

**Dodge Industrial, Inc.**  
1061 Holland Road  
Simpsonville, SC 29681  
+1 864 297 4800

