



# Instruction Manual for DODGE PARA-FLEX® High Speed and Flywheel Couplings

These instructions must be read thoroughly before installation or operation.

**WARNING: TO INSURE THAT DRIVE IS NOT UNEXPECTEDLY STARTED, TURN OFF AND LOCK OUT OR TAG POWER SOURCE BEFORE PROCEEDING. FAILURE TO OBSERVE THESE PRECAUTIONS COULD RESULT IN BODILY INJURY.**

## PARA-FLEX® High Speed Couplings

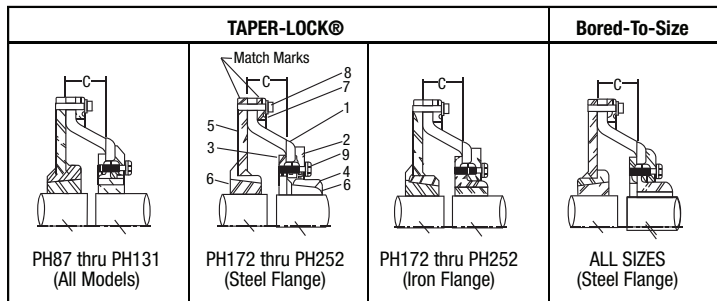

- (1) Flexible Element
- (2) External Clamp Ring\*
- (3) Internal Clamp Ring\*
- (4) Flange Assembly
- (5) Disc Assembly
- (6) TAPER-LOCK® Bushing
- (7) Bolt Ring
- (8) Screws (Disc. Assy.)
- (9) Screws (Clamp Ring)
- (10) Flange Spacer Ring (See Fig. 1)

\*Clamp rings are included in the flange assembly.

**Note: Use only SAE grade 8 screws and hardened washers.**

## PARA-FLEX® Flywheel Couplings

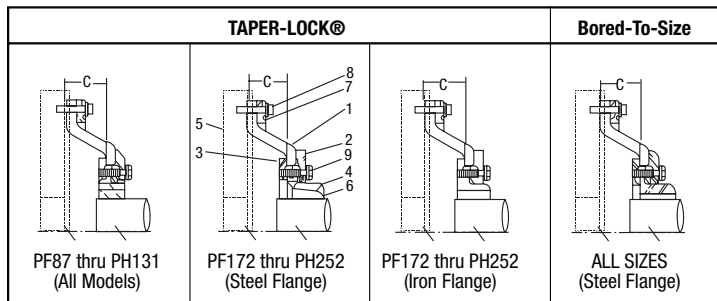

- (1) Flexible Element
- (2) External Clamp Ring\*
- (3) Internal Clamp Ring\*
- (4) Flange Assembly
- (5) Flywheel
- (6) TAPER-LOCK® Bushing
- (7) Bolt Ring
- (8) Screws (Bolt Ring)
- (9) Screws (Clamp Ring)
- (10) Flange Spacer Ring (See Fig. 1)
- (11) Adapter (See Fig. 2)

\*Clamp rings are included in the flange assembly.

**Note: Use only SAE grade 8 screws and hardened washers.**

### INSTALLATION:

1. **Disc Assembly Installation:** Install disc assembly on shaft with TAPER-LOCK® bushing. Disc assembly can be installed with bushing screws toward either side. Tighten the TAPER-LOCK® bushing in accordance with the instructions packed with the bushings. Note balancing match marks on disc and bolt ring O.D.

**NOTE:** Disregard Step 1 when installing PARA-FLEX Flywheel Couplings.

2. **Flange Installation:** Press or shrink straight bored flange assemblies on the shafts. Install TAPER-LOCK® flanges per instructions packed with the bushings. TAPER-LOCK® flanges on coupling sizes 87 thru 131 are reversible to permit locating bushing screws on the inside or outside of the coupling as desired or convenient. Note: The PX140 flange assembly (used on the 172 coupling) requires a flange spacer ring which must be installed before mounting flange assembly on the shaft. On models with iron flanges the spacer ring is installed between the flange assembly and external clamp ring, and on models with steel flanges it is installed between the flange assembly and internal clamp ring. See Fig. 1.

**WARNING: Because of the possible danger to persons(s) or property from accidents which may result from the improper use of products, it is important that correct procedures be followed: Products must be used in accordance with the engineering information specified in the catalog. Proper installation, maintenance and operation procedures must be observed. The instructions in the instruction manuals must be followed. Inspections should be made as necessary to assure safe operation under prevailing conditions. Proper guards and other suitable safety devices or procedures as may be desirable or as may be specified in safety codes should be provided, and are neither provided by Dodge nor are the responsibility of Dodge. This unit and its associated equipment must be installed, adjusted and maintained by qualified personnel who are familiar with the construction and operation of all equipment in the system and the potential hazards involved. When risk to persons or property may be involved, a holding device must be an integral part of the driven equipment beyond the speed reducer output shaft.**

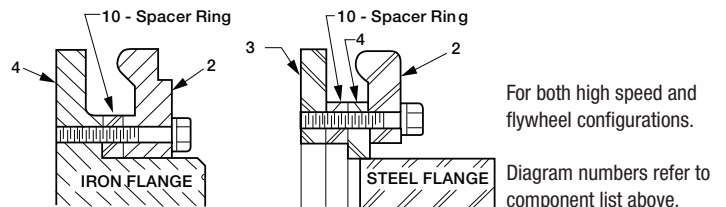

**Fig. 1 Flange Spacer Ring Location**

3. **Align Shafts:** Position shafts for angular and parallel alignment within  $\pm 1/64$ " for normal industrial applications. Position flange assembly so that dimension "C" will be maintained. If shaft end float is to occur, locate shaft at the mid-position of end float\*. Measure dimension "C", in Table 1, at four places around the diameter. These measurements should not vary more than dimension "D".  
\*Where limited end float is required or sleeve bearings are used, consult DODGE.
4. **Flexible Element Installation:** Slip bolt ring over flange and rest it on shaft. Remove clamp ring screws and internal clamp ring. Place internal clamp ring inside the element and reassemble to flange seating the bead of the element on the flange. Tighten clamp ring screws alternately and evenly to the torque values shown in column "A" of Table 1.

On coupling sizes 172 thru 252 (PH or PF) iron construction only, remove external clamp ring and rest it on shaft. Turn element sideways to shaft and push over flange. Seat element on flange and reassemble clamp ring and screws. Place bolt ring and screws in position.

On size PF213 place adapter between flexible element and flywheel (See Fig. 2). Line up unthreaded holes in adapter with threaded holes in flywheel and place long screws in these holes. Fasten element to adapter with short screws. Tighten screws alternately and evenly and torque to values shown in column "B", in Table 1.

**NOTE:** On PH style couplings match marks on O.D. of bolt ring and disc must be aligned.

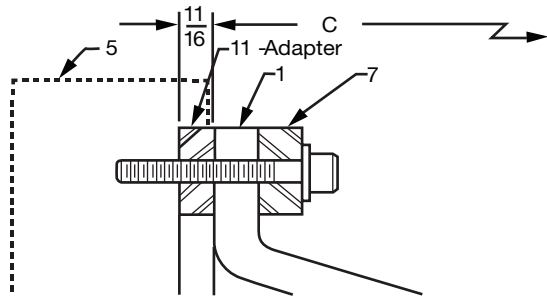

**PF213 Coupling Only**  
**Fig. 2 Adapter Location**

- 5. Check Shaft Alignment:** Although shafts may be perfectly aligned at installation, some parallel and angular misalignment usually develops in usage because of shift of the driving and driven units. Check both parallel and angular alignments by mounting indicators near the O.D. of the flange as shown in Fig. 3 and rotate the coupling thru 360°. For good installation neither indicator reading should exceed the value shown in column "D" in Table 1. Both alignments should be rechecked after any repositioning.

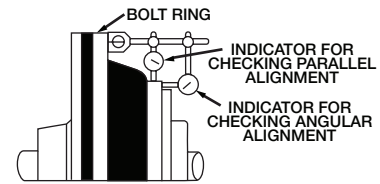

**Fig. 3**

Coupling Size	Flange Assembly Size	Wrench Torque Pound - Inches		B	C	D
		A				
		Steel	Iron			
		Plain	Plain	Plain		
87	PX70	290	290	180	1-5/8	.020
96	PX80	290	290	300	1-15/16	.025
116	PX100	480	480	360	2	.030
131	PX110	480	480	420	2-1/2	.035
172	PX140	1150	1080	600	2-15/16	.045
192	PX160	1150	2160	780	3-5/16	.050
213	PX190	2400	2160	840	3-5/8	.055
252	PX220	4020	3600	2880	5-5/8	.060

**Table 2 - PARA-FLEX® Couplings High Speed & Flywheel Bolt Ring Screws and Washers**

COUPLING SIZE	PH/PF QUANTITY	PH (Disc Ass'y) SOCKET HEAD CAP SCREW	PF (Bolt Ring Ass'y) SOCKET HEAD CAP SCREW	PF/PH HI COLLAR LOCK WASHER	PX FLANGE (REF.)
87	8	5/16-18 x 1-1/4" 417331	5/16-18 x 1-1/2" 417332	5/16" 419046	P X 70
96	6	3/8-16 x 1-1/2" 417336	3/8-16 x 1-3/4" 417311	3/8" 419047	P X 80
116	8	3/8-16 x 1-1/2" 417336	3/8-16 x 1-3/4" 417311	3/8" 419047	P X 100
131	8	3/8-16 x 2" 417334	3/8-16 x 1-3/4"	3/8" 419047	P X 110
172	8	1/2-13 x 2" 417306	1/2-13 x 2-1/4" 417310	1/2" 419050	P X 140
192	8	1/2-13 x 2" 417306	1/2-13 x 2-1/4" 417310	1/2" 419050	P X 160
213	12	5/8-11 x 2-1/4" 417307	(6) 5/8-11 x 3" 417312	5/8" 419052	P X 190
252	12	5/8-11 x 2-1/2" 417308	5/8-11 x 2-3/4" 417309	5/8" 419052	P X 220

**NOTE:** PH Bolt Rings are matched and balanced with Disc and are not sold separately. PF Bolt Rings may be used if customer assumes balance responsibility.

**Dodge Industrial, Inc.**  
1061 Holland Road  
Simpsonville, SC 29681  
+1 864 297 4800

