



Special Duty Bearings

Instruction Manual

3-11/16" to 6" Bore

These instructions must be read thoroughly before installation or operation. This instruction manual was accurate at the time of printing. Please see dodgeindustrial.com for updated instruction manuals.

WARNING: To ensure the drive is not unexpectedly started, turn off and lock-out or tag power source before proceeding. Failure to observe these precautions could result in bodily injury.

WARNING: All products over 25 kg (55 lbs) are noted on the shipping package. Proper lifting practices are required for these products.

INSTALLATION

1. Shaft should be within commercial tolerances, straight, smooth, and clean. Apply a coating of light oil or other rust inhibitor to the shaft in the bearing area.
2. Loosen lockscrews in adapter nuts to prevent damage to adapter. (If necessary to expand adapter, loosen adapter nut at closed end of housing approximately two turns and tap on the end of the nut). Apply silicone sealant to the split in the adapter sleeve. This provides protection against contaminants.
3. Slide bearing to desired position on the shaft.
4. Do not bolt outer housing to support until bearing is tightened on shaft.
5. Block up shaft to remove weight from bearing. This is extremely important where the bearing and shaft are large and where heavy equipment is mounted on shaft.
6. Loosen (turn counterclockwise 2-3 turns) adapter nut at open end of housing (end opposite the instruction plate).
7. Tighten (turn clockwise) adapter nut at closed end of housing (end with the instruction plate). Check other nut periodically to see that it is loose as in step 6. Make sure this nut does not touch end of bearing cone during tightening operation.

When considerable effort is required to turn adapter nut, use sledge and brass bar as shown in illustrations. Keep tightening nut with barring rod or spanner wrench while hitting on brass bar.

The adapter nut is nearly tight when a solid sound or ring, such as is made by hitting directly on the end of a solid shaft, develops in the adapter nut. If possible, tighten more by hitting on the barring rod or spanner wrench and the brass bar simultaneously.

(Refer to Figures 2 through 5 for installation methods.)

NOTE: When installing the bearing, it is very important that the split tapered adapter (bearing sleeve) be drawn down on the shaft as tightly as possible. Use one of the following illustrated methods to overcome friction between the tapered adapter and the taper-bored cone and between the threads of the adapter and the adapter nut. The sudden jar developed by the sledge and brass bar (while the tightening force is being applied to the adapter nut) helps to overcome the friction, allowing the nut to be tightened to a greater degree than otherwise possible.

WARNING: Because of the possible danger to person(s) or property from accidents which may result from the improper use of products, it is important that correct procedures be followed. Products must be used in accordance with the engineering information specified in the catalog. Proper installation, maintenance and operation procedures must be observed. The instructions in the instruction manuals must be followed. Inspections should be made as necessary to assure safe operation under prevailing conditions. Proper guards and other suitable safety devices or procedures as may be desirable or as may be specified in safety codes should be provided, and are neither provided by Dodge® nor are the responsibility of Dodge. This unit and its associated equipment must be installed, adjusted and maintained by qualified personnel who are familiar with the construction and operation of all equipment in the system and the potential hazards involved. When risk to persons or property may be involved, a holding device must be an integral part of the driven equipment beyond the speed reducer output shaft.

8. If possible, line up one lockscrew hole in adapter nut with a slot in end of adapter. If adapter nut can no longer be tightened, do not back off to line up with slot in adapter.
9. Tighten (turn clockwise) adapter nut at open end of housing until it is snug against end of bearing cone. Tighten lockscrew in this nut onto shaft or onto adapter.
10. Check hold-down bolts in outer housing to see they are loose and free. (If too tight, an excessive thrust load could be imposed on bearing.) If bolts are very tight, it may be advisable to loosen adapter to move slightly on shaft.
11. Tighten hold-down bolts to secure outer housing to support. Mount a dial indicator on the shaft near the bearing. Place the indicator probe so that it contacts the face of the inner unit housing on the closed end (end with instruction plate). See Figure 1.
12. Zero the indicator and sweep the entire face, noting the total indicator runout (TIR).
13. If the TIR is greater than the value shown in Table 2, gently tap the face of the inner unit housing to correct the runout. Repeat steps 3 and 4 until the TIR is less than the value shown in Table 2.
14. If the TIR is less than or equal to the value in Table 2, tighten the cap bolts per values in Table 1.
15. The non-expansion bearing is now installed. Repeat steps 1-15 for the expansion bearing.

16. The expansion bearing is now installed.

EXPANSION BEARING: Inner unit should be located in center of outer housing. For maximum expansion, shift inner unit to the side of the outer housing closest to the non-expansion bearing.

17. After a short run make sure adapter is tight: loosen lock screws; loosen hold-down bolts; perform steps 5 to 10 inclusive. Tighten down bolts.

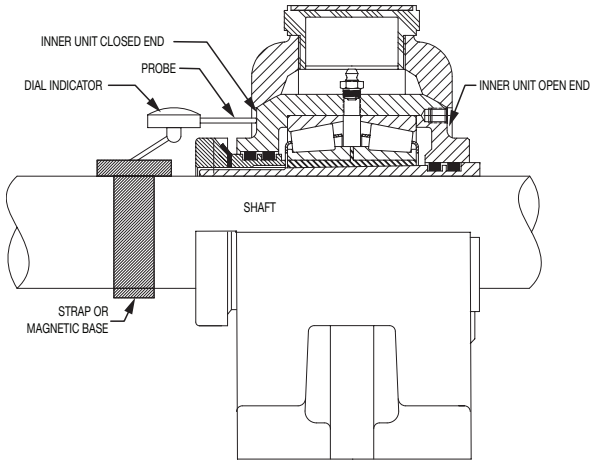

Figure 1

Table 1 - Recommended Tightening Torques

Pillow Block Size	Cap Bolts		
	Quantity	Size	Torque (Ft.-Lbs.)
3-11/16-4 NE & Exp.	2	1-1/8-7	350
4-7/16-4-1/2 NE	4	7/8-9	175
4-7/16-4-1/2 Exp.	2	1-1/8-7	350
4-15/16-5 NE	4	1-8	250
4-15/16-5 Exp.	2	1-1/4-7	500
5-7/16-6 NE & Exp.	2	1-8	250

Flange Size	Cap Bolts		
	Quantity	Size	Torque (Ft.-Lbs.)
3-11/16-4-1/2	2	1-8	250
4-15/16-5	4	1-8	250
5-7/16-6	2	1-1/4-7	500

Table 2- Total Indicator Runout (TIR)

Shaft Size (in.)	TIR (in.)
3-11/16 thru 4	0.0090
4-7/16 thru 4-1/2	0.0105
4-15/16 thru 5	0.0110
5-7/16 thru 6	0.0135

REMOVAL INSTRUCTIONS

1. Loosen lockscrew in both adapter nuts and loosen hold-down bolts. Block up shaft to remove weight from bearing.
2. Loosen (turn counterclockwise) adapter nut at closed end of housing approximately two turns.
3. Tighten (turn clockwise) nut at open end of housing. Use sledge and brass bar as in Figure 5 to break the cones loose on the adapter, thus allowing the adapter to loosen on shaft.

UNIT REPLACEMENT INSTRUCTIONS

1. Remove bearing from shaft per removal instructions.
2. Match mark cap and base of each outer housing before removing cap.
3. Fit each unit to its outer housing before putting on shaft.
4. Add or remove shims between cap and base as required to obtain "snug" fit of unit in outer housing with cap bolts drawn down securely. See Table 1 for tightening torques.
5. Check fit by prying against lubrication stud in unit through the lubrication hole in housing cap with a screw driver or small pinch bar depending upon the size of the pillow blocks.
6. The "snug" fit becomes a matter of judgment. A "loose or sloppy" fit may allow a unit to move in its outer housing thus wearing the mating surfaces. Too "tight" a fit will not allow the unit to move and compensate for misalignment and for shaft deflection caused by belt pull and dead weight.
7. When reassembling pillow blocks, make sure match marks (step 2) on cap and bases match.
8. Install bearing on shaft per instructions.

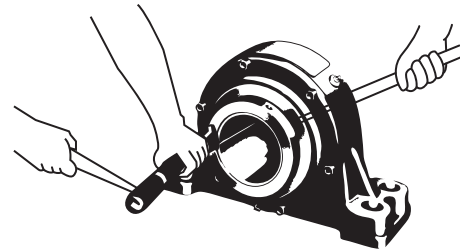

Figure 2 - Preferred Method

Hitting directly on face of adapter nut with brass bar parallel to shaft, while applying torque with barring rod to tighten nut. ★▲

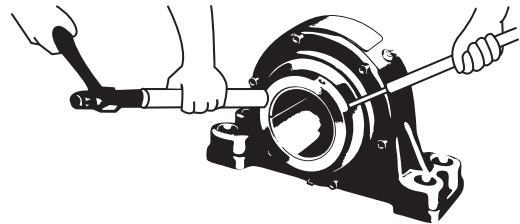

Figure 3

Hitting on nut at an angle where unable to hit at right angle to face. This method is not as effective as the method shown in Figure 2. ★▲

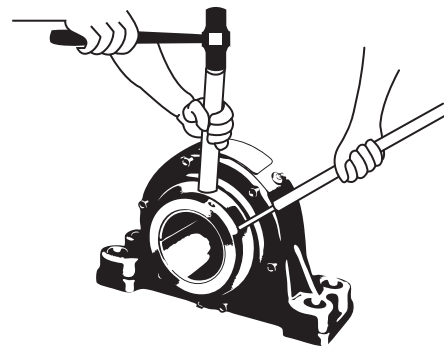

Figure 4

Hitting on O.D. of nut with brass bar held at right angle to shaft. This method is not as effective as the methods shown in Figures 2 or 3. ★▲

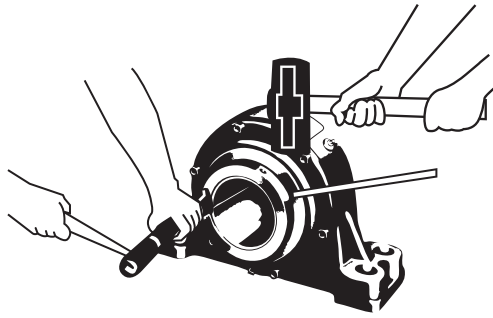

Figure 5

This is an alternate method to those shown in Figures 2-4 in that a spanner wrench is used in place of the barring rod.★■

- ★ For 3-11/16" to 5" shaft sizes not less than 1-1/4" diameter: for 5-7/16" to 6" shaft sizes not less than 1-1/2" diameter.
- ▲ A 12" length of drill rod which is 1/64" less in diameter than the barring pockets is recommended for use as barring rod. Pipe should be used as shown for additional leverage.
- Pin in spanner wrench should be 1/64" less in diameter than the barring pockets.

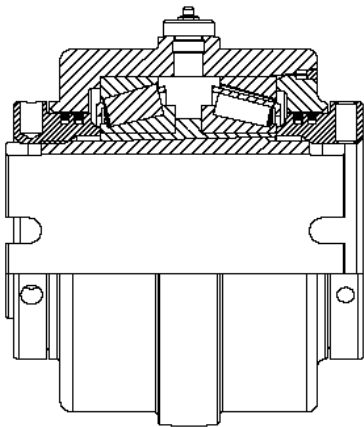

Figure 6 - Expansion Type

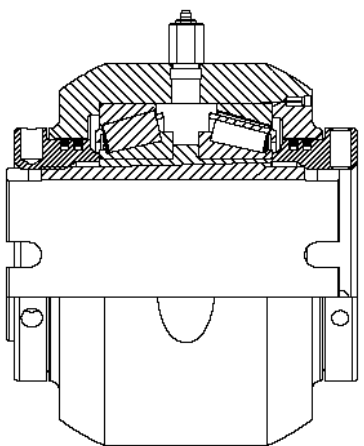

Figure 7 - Non-Expansion Type

LUBRICATION INSTRUCTIONS

Storage or Special Shutdown: If exposed to wet or dusty conditions or to corrosive vapors, extra protection is necessary: Add grease until it shows at the seals; rotate the bearing to distribute grease; cover the bearing. After storage or idle period, add a little fresh grease before running.

High Speed Operation: In the higher speed ranges too much grease will cause overheating. The amount of grease that the bearing will take for a particular high speed application can only be determined by experience — see "Operating Temperature." If excess grease in the bearing causes overheating, it will be necessary to remove grease fitting (also drain plug when furnished) to permit excess grease to escape. The bearing has been greased at the factory and is ready to run. When establishing a relubrication schedule note that a small amount of grease at frequent intervals is preferable to a large amount at infrequent intervals.

Operation in Presence of Dust, Water or Corrosive Vapors: Under these conditions the bearing should contain as much grease as speed will permit, since a full bearing with consequent slight leakage is the best protection against entrance of foreign material. In the higher speed ranges too much grease will cause overheating—see "High Speed Operation" above. In the lower speed ranges it is advisable to add extra grease to a new bearing before putting into operation. Bearings should be greased as often as necessary (daily if required) to maintain a slight leakage at the seals.

Normal Operation: This bearing has been greased at the factory and is ready to run. Table 3 is a general guide for relubrication. However, certain conditions may require a change of lubricating periods as dictated by experience. See "High Speed Operation" and "Operation in Presence of Dust, Water or Corrosive Vapors" above.

Table 3 - Lubrication Guide

Hours Run per Day	Suggested Lubrication in Weeks				
	1 to 250 RPM	251 to 500 RPM	501 to 750 RPM	751 to 1000 RPM	1001 to 1250 RPM
8	12	12	10	7	5
16	12	7	5	4	2
24	10	5	3	2	1

Operating Temperature: Abnormal bearing temperature may indicate faulty lubrication. Normal temperature may range from "cool to warm to the touch" up to a point "too hot to touch for more than a few seconds," depending on bearing size and speed, and surrounding conditions. Unusually high temperature accompanied by excessive leakage of grease indicates too much grease. High temperature with no grease showing at the seals, particularly if the bearing seems noisy, usually indicates too little grease. Normal temperature and a slight showing of grease at the seals indicate proper lubrication.

Kind of Grease: Many ordinary cup greases will disintegrate at speeds far below those at which Dodge bearings will operate successfully if proper grease is used. Dodge bearings have been lubricated at the factory with an NLGI #2 lithium complex base grease. Relubricate with lithium or lithium complex base grease, or a grease which is compatible with the original lubricant and suitable for roller bearing service. In unusual or doubtful cases the recommendation of a reputable grease manufacturer should be secured.

Special Operating Conditions: Refer acid, chemical, extreme or other special operating conditions to Dodge Industrial Engineering in Greenville, SC at (864)284-5700.

Dodge Industrial, Inc.
1061 Holland Road
Simpsonville, SC 29681
+1 864 297 4800

