

D-Mount Adapter System Instruction Manual

These instructions must be read thoroughly before installation or operation. This instruction manual was accurate at the time of printing. Please see dodgeindustrial.com for updated instruction manuals.

WARNING: To ensure the drive is not unexpectedly started, turn off and lock-out or tag power source before proceeding. Failure to observe these precautions could result in bodily injury.

WARNING: All products over 25 kg (55 lbs) are noted on the shipping package. Proper lifting practices are required for these products.

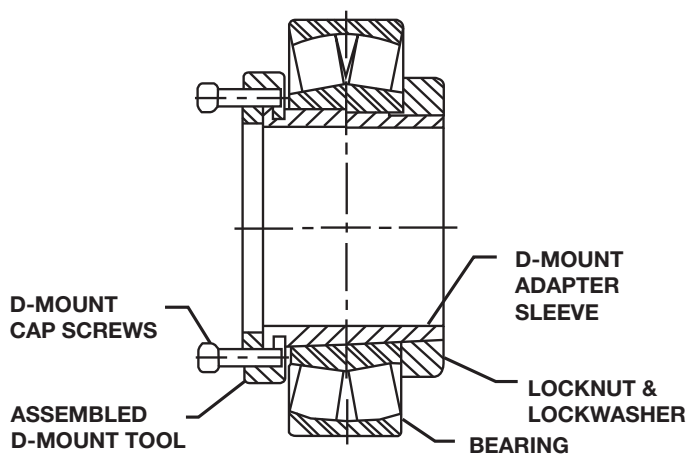

Figure 1

WARNING: Because of the possible danger to person(s) or property from accidents which may result from the improper use of products, it is important that correct procedures be followed. Products must be used in accordance with the engineering information specified in the catalog. Proper installation, maintenance and operation procedures must be observed. The instructions in the instruction manuals must be followed. Inspections should be made as necessary to assure safe operation under prevailing conditions. Proper guards and other suitable safety devices or procedures as may be desirable or as may be specified in safety codes should be provided, and are neither provided by Dodge® nor are the responsibility of Dodge. This unit and its associated equipment must be installed, adjusted and maintained by qualified personnel who are familiar with the construction and operation of all equipment in the system and the potential hazards involved. When risk to persons or property may be involved, a holding device must be an integral part of the driven equipment beyond the speed reducer output shaft.

DESCRIPTION

The purpose of the Dodge D-Mount Adapter and D-Mount tool is to facilitate removal of tapered bore spherical roller bearings from the shaft. The Dodge D-Mount tool can be used only in conjunction with a Dodge D-Mount adapter sleeve.

INSTALLATION

1. Remove cap from pillow blocks, then lift shaft so that backside of mounted bearing is exposed to receive D-Mount tool.
2. With a screw driver pry up tang of lockwasher engaged with locknut.
3. Turn locknut counterclockwise two to three turns.
4. Remove socket head cap screws (1) from the D-Mount tool to separate the two halves.
5. Wrap the two halves (2) around the grooved back side of the adapter, stamped side away from bearing. Prior to wrapping around adapter, make sure cap screws are backed off flush with the unstamped side (Figure 1).
6. Reinstall the two socket head cap screws (1) to join the two halves securely. Torque cap screws per Table 1.
7. Using the Hex Key supplied with the D-Mount tool, screw in the face mounted socket head cap screws (3) until all just contact the face of the bearing inner ring.
8. Begin turning sequentially, each socket head cap screw 15° at a time in a clockwise direction until the spherical bearing inner ring slides off the adapter. At all times while tightening D-Mount cap screws, make sure locknut is backed off from the front face of the bearing inner ring. For a more efficient method of applying torque to the D-Mount cap screws, use a hardened hex driver and a ratchet type wrench.
9. After the bearing is removed from the shaft, remove D-Mount tool from the adapter sleeve. Reassemble and store ready for the next time it is needed.

Table 1–Cap Screw Torque

D-Mount Tool #	Cap Screw Size (inch)	Hex Key Size (mm)	Torque	
			Nm	ft-lbs
09-10	M5	4 mm	5.1	4.5
11-17	M6	5 mm	10.5	7.74
18-22	M8	6 mm	26	19.2
24-36	M12	10 mm	89	65.65
38-44	M16	14 mm	215	158.6

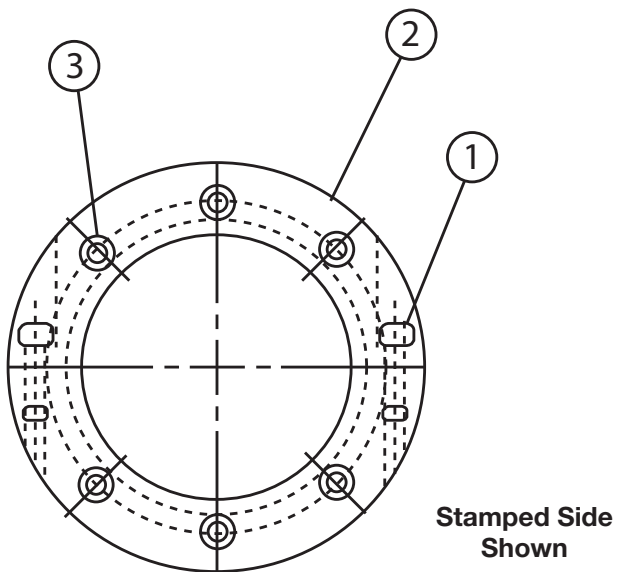

Figure 2

Dodge Industrial, Inc.
 1061 Holland Road
 Simpsonville, SC 29681
 +1 864 297 4800

