

Instruction Manual for Dodge® Screw Conveyor Drive

MIMA Wrapper SCXT325A Speed Reducer

These instructions must be read thoroughly before installation or operation. This instruction manual was accurate at the time of printing. Please see dodgeindustrial.com for updated instruction manuals.

WARNING: To ensure the drive is not unexpectedly started, turn off and lock-out or tag power source before proceeding. Failure to observe these precautions could result in bodily injury.

WARNING: All products over 25 kg (55 lbs) are noted on the shipping package. Proper lifting practices are required for these products.

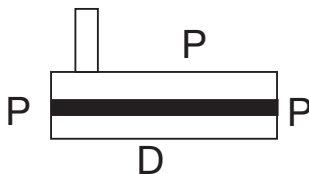

Figure 1 - MIMA Mounting Positions
Lubrication

SCT325A MIMA Reducer is shipped with 3-1/4 quarts of Mobil SHC 634 ISO 460 VG. This is the recommended oil for use with the MIMA reducer.

WARNING: Because of the possible danger to person(s) or property from accidents which may result from the improper use of products, it is important that correct procedures be followed. Products must be used in accordance with the engineering information specified in the catalog. Proper installation, maintenance and operation procedures must be observed. The instructions in the instruction manuals must be followed. Inspections should be made as necessary to assure safe operation under prevailing conditions. Proper guards and other suitable safety devices or procedures as may be desirable or as may be specified in safety codes should be provided, and are neither provided by Dodge nor are the responsibility of Dodge. This unit and its associated equipment must be installed, adjusted and maintained by qualified personnel who are familiar with the construction and operation of all equipment in the system and the potential hazards involved. When risk to persons or property may be involved, a holding device must be an integral part of the driven equipment beyond the speed reducer output shaft.

Guidelines for Torque-Arm Reducer Long Term Storage

During periods of long storage, or when waiting for delivery or installation of other equipment, special care should be taken to protect a gear reducer to have it ready to be in the best condition when placed in service.

By taking special precautions, problems such as seal leakage and reducer failure due to the lack of lubrication, improper lubrication quantity, or contamination can be avoided. The following precautions will protect gear reducers during periods of extended storage:

Preparation

1. Drain the oil from the unit. Add a vapor phase corrosion inhibiting oil (VCI-105 oil by Daubert Chemical Co.) in accordance with Table 4.
2. Seal the unit air tight.
3. Cover the shaft extension with a waxy rust preventative compound that will keep oxygen away from the bare metal (Non-Rust X-110 by Daubert Chemical Co.).
4. The instruction manuals and lubrication tags are paper and must be kept dry. Either remove these documents and store them inside or cover the unit with a durable waterproof cover which will keep moisture away.
5. Protect the reducer from dust, moisture, and other contaminants by storing the unit in a dry area.
6. In damp environments, the reducer should be packed inside a moisture-proof container or an envelope of polyethylene containing a desiccant material. If the reducer is to be stored outdoors, cover the entire exterior with a rust preventative.

When Placing the Reducer into Service

1. Clean the shaft extensions with petroleum solvents.
2. Fill the unit to the proper oil level using a recommended lubricant. The VCI oil will not affect the new lubricant.
3. Follow the installation instructions provided in this manual.

Table 4 — Quantities of VCI #105 Oil

Case Size	Quarts or Liters
SCXT3A	.1

VCI #105 & #10 are interchangeable.

VCI #105 is more readily available.

REPLACEMENT PARTS

With access to an arbor press, equipment for heating and shrinking bearings and gears on shafts, and the tools normally found in a maintenance department, the MIMA SCXT325A speed reducer can easily be disassembled and reassembled by careful attention to the following instructions.

Cleanliness is very important to prevent the introduction of dirt into the bearings and other parts of the reducer. The oil seals are of the rubbing type and considerable care should be exercised during disassembly or reassembly to avoid damage to the surfaces on which the seals rub. Any sharp edges on the input shaft or output hub should be covered with adhesive tape or paper before performing any work on the unit. Nicks and burrs on surfaces of the input shaft or output hub should be removed.

Ordering Parts

When ordering parts, specify MIMA SCXT325A and part number, part name, and quantity.

Parts that must be pressed from shafts or output hub should be removed before ordering parts. This assures that those parts, if damaged during pressing operation, will be replaced.

It is recommended that when a pinion or gear is replaced, its mating gear or pinion be replaced also. This ensures that the gear teeth will mesh properly. If the large gear on the output hub must be replaced, it is suggested that an output hub assembly, consisting of a gear assembled on an output hub, be ordered to secure an output hub with undamaged surfaces on which the oil seals rub. However, if the old output hub is to be used, carefully press the gear and bearing cones off. Thoroughly examine the area under the oil seals for scratches or any other damage resulting from the pressing operation. To prevent oil leakage at the oil seals, the rubbing area must be smooth.

Replacements for the old oil seals should be ordered, due to the probability of these parts being damaged during disassembly.

If replacing a bearing, output hub or a shaft, it is advisable to order a set of shims for adjustment of bearings on the shaft assembly. If replacing a housing, a set of shims should be ordered for each shaft assembly because the adjustment of bearings on each shaft assembly is affected.

WARNING: Equipment being removed may be too heavy to control manually. Support it by external means. Failure to observe these precautions could result in bodily injury.

Disconnect any electrical power to the drive. Drain lubricant from reducer. Uncouple drive shaft and screw. Remove nuts from trough end studs. Support drive by means of hoist and carefully pull unit away from trough end to slide drive shaft out of screw.

Disassembly

1. Position reducer on its side and remove bolts. Gently tap the output hub and input shaft with a soft hammer (rawhide, not a lead hammer) to separate the housing halves. Open housing evenly to prevent damage to the parts inside
2. Lift shaft, gear and bearing assemblies from housing.
3. Remove seals, seal carriers and bearing cups from housing.
4. Clean all parts in solvent, inspect for damage and coat with oil.

WARNING: Solvents can be toxic and/or flammable. Follow manufacturer's safety procedures and directions. Failure to observe these precautions could result in bodily injury.

Reassembly:

1. **Output Hub Assembly:** Heat gear to 325° to 350°F for shrinking onto output hub. Heat bearing cones to 250° to 270°F for shrinking onto output hub.
2. **Countershaft Assembly:** Heat gear to 325° to 350°F and bearing cones to 250° to 270°F for shrinking onto shaft.
3. **Input Shaft Assembly:** Shaft and pinion are integral. Heat bearing cones to 250° to 270°F for shrinking onto shaft.
4. Drive the dowel pins back into position in the right hand housing half.
5. Install countershaft cover and input bearing cover in right-hand housing half. Place housing half on blocks to allow for protruding end of output hub. Install bearing cups in right-hand housing half making sure they are properly seated.
6. Mesh output hub gear and small countershaft gear together and set in place in housing. Set input shaft assembly in place in the housing. Make sure bearing rollers (cones) are properly seated in their cups. Set bearing cups for left-handed housing half in place on their rollers.
7. Clean housing flange surfaces on both halves, making sure not to nick or scratch flange face. Place a new bead of gasket eliminator on flange face and spread evenly over entire flange leaving no bare spots. Place other housing half into position and tap with a soft hammer (rawhide, not lead hammer) until housing bolts can be used to draw housing halves together. Torque housing bolts to 720 lb-ins.

CAUTION: If too much sealant is used, it will run into the bearing, and too little sealant will result in an ineffective seal.

8. Apply RTV to all seal O.D.s. Extreme care should be used in installing seals on input shaft and output hub to avoid damage to seals due to contact with sharp edges of the keyseat in the input shaft or the retaining ring groove in the output hub. This danger of damage and consequent oil leakage can be decreased by covering the keyseat and groove with tape or paper which can be removed subsequently. Chamfer or burr housing bore if end of bore is sharp or rough. Fill cavity between lips of seal with grease. Seats should be pressed or tapped with a soft hammer evenly into place in the housing, applying force only on outer corner of seals. A slight oil leakage at the seals may be evident during initial running in, but will disappear unless the seals have been damaged.

Place output hub seal carrier in position, shim and torque bolts per special procedures.

9. Fill with approximately 3¼ quarts of Mobil SHC 634 oil, ISO 460 VG.

MODIFIED ASSEMBLY PROCEDURE SCXT325A MIMA/ITW (WRAPPER UNITS)

1. 1. All assembly procedures for standard SCXT325A should be followed except for the following changes in shimming of output bearing.
2. 2. New output bearing shimming procedures:
 - a. Place output bearing cup in left half of housing. Ensure the bearing cup is correctly seated.
 - b. Position output hub seal carrier (without shims) and install two carrier screws diametrically opposed.
 - c. Torque each screw to 50 lb.-in. Rotate the output hub to roll in the bearings, then torque each screw to 100 lb.-in. Rotate the output hub again to roll in the bearings.
 - d. Seat output bearings by tapping the seal carrier with a hammer; turning the output hub through 360 degrees to further roll in the bearings. Torque carrier bolts again to 100 lb.-in. Repeat this process of hammering, turning the output hub, and torquing to 100 lb.-in. until bearings are completely seated (3-4 seatings may be required).
 - e. With a feeler or taper gauge, measure the gap between the housing and the carrier, clockwise from and next to each screw.
 - f. To determine the required shim pack thickness, subtract .005 in. from the average of the two gauge readings (Pack Thickness = Gauge Average - .005 in.).
 - g. Remove the output hub seal carrier and install the required shims (shim pack thickness should be inspected with a 0-1" micrometer).

Note: Total shim thickness per carrier should not include more than .009" plastic shims. All other shims should be metal, and each plastic shim should be inserted between two metal shims.
 - h. Continue with normal assembly procedure from this point. (Carrier bolt torque should be 204 lb.-in.)
3. Place countershaft bearing carrier in position without shims and install two carrier screws diametrically opposed. Torque each screw to 25 lb.-ins. Rotate the output hub to roll in the bearings and then torque each screw once to 50 lb.-ins. Do not retorquer screws. Again turn countershaft to roll in the bearings. With a feeler or taper gauge, measure the gap between the housing and the carrier, clockwise from and next to each screw. To determine the required shim thickness, take the average of the two feeler gauge readings. Remove carrier and install the required shims.

Note: Total shim thickness per carrier should not include more than .009" plastic shims, and each plastic shim should be inserted between two metal shims. Place a diameter bead of Dow Corning RTV732 sealant on the face around the I.D. of the end shim (sealant is to be between reducer housing and shim) and install carrier on reducer housing. Torque carrier bolts to 204 lb.-ins. Countershaft should have an axial end play of .001" to .003".
4. Using the same procedure as in step 3 adjust the input shaft bearings, except the axial end play should be .002" to .003". Torque bearing carrier to 204 lb.-ins.

Table 5 — Manufacturers' Part Numbers For Replacement Output Shaft Bearings

TORQUE-ARM Reducer Drive Size	Output Hub Bearing	
	DODGE Part Number	Manufacturer's Part Number
SCXT3A	402272	LM814849
	403127	LM814810

Table 6 — Manufacturers' Part Numbers For Replacement Countershaft Bearings

TORQUE-ARM Size	Countershaft Bearing Input Side		Countershaft Bearing Adapter Side	
	Dodge Part No.	Manufacturer's Part Number	Dodge Part No.	Manufacturer's Part Number
SCXT3A	402273	15102	402273	15012
	403094	15245	403094	15245

Table 7 - Manufactures' Part Numbers For Replacement Input Shaft Bearings

TORQUE-ARM Size	Input Bearing Input Side		Input Bearing Adapter Side	
	Dodge Part No.	Manufacturer's Part Number	Dodge Part No.	Manufacturer's Part Number
SCXT3A	402204	LM48548A	402273	15102
	403139	LM48510	403094	15245

Parts For SCXT325 MIMA Reducer			
Reference	Name of Part	Number Required	SCXT3A
16	HOUSING	1	961405
19	Housing Bolt	8	411463
	Washer	16	419057
22	Hex Nut	8	407268
24	Dowel Pin	2	420055
①	Pipe Plug	5	430031
①	Magnetic Plug	1	430060
21	Countershaft Cover Screws (Backstop Side)	4	416519
26	Countershaft Bearing Cover (Backstop Side)	1	243559
28	Input Shaft Seal Carrier	1	243543
30 ②	Input Shaft Bearing Shim Pack	2 ③	389704
	.002" Thick	④	427841
	.005" Thick	④	427842
	.010" Thick	④	427843
	.025" Thick	④	427844
32	Carrier and Cover Screws	14	411390
33	Lockwasher	14	419010
34	Backstop Cover	1	361062
40 ②	Input Shaft		
	with Pinion 25:1 Ratio	1	961404
41	Input Shaft Key	1	443032
44 ②	Input Shaft Bearing	Cone	1 402204
45 ②	(Input Side)	Cup	1 403139
46 ②	Input Shaft Bearing	Cone	1 402273
47 ②	(Backstop Side)	Cup	1 403094
	COUNTERSHAFT ASSEMBLY ⑤ 25:1 Ratio	1	389701
48	⑥ Countershaft with Pinion	1	243555
50 ②	⑥ First Reduction Gear 25:1 Ratio	1	243239
52 ②	⑥ Key	1	243215
54 ②	Countershaft Bearing	Cone	1 402273
55	(Input Side)	Cup	1 403094
56 ②	Countershaft Bearing	Cone	1 402273
57 ②	(Backstop Side)	Cup	1 403094
58	Countershaft Bearing Cover (Input Side)	1	243545
59 ②	Countershaft Bearing Shim Pack	2 ③	389705
	.002" Thick	④	427845
	.005" Thick	④	427846
	.010" Thick	④	427847
	.025" Thick	④	427848
60 ②	OUTPUT HUB ASSEMBLY ⑤	1	389702
62 ②	⑥ Output Hub	1	961297
64 ②	⑥ Output Gear	1	243570
	⑥ Output Gear Key	2	243216
76	Output Hub Seal Carrier (Input Side)	1	C15073
77	Roll Pin	1	409022
80 ②	Output Hub	Cone	2 402272
81 ②	Bearing	Cup	2 403127
82 ②	Output Hub Bearing Shim Pack	2 ③	389706
	.002" Thick	④	427849
	.005" Thick	④	427850
	.010" Thick	④	427851
	.025" Thick	④	427852
42 ②	SEAL KIT ⑤ ②	1	389720
78 ②	⑥ Input Shaft Seal	1	243558
	⑥ Output Shaft Seal	2	243578

Parts For SCXT325 MIMA Reducer			
Reference	Name of Part	Number Required	SCXT3A
①	RTV Sealant, Tube	1	465044
①	⑥ Key (Output)	1	443089

- ① Not shown on drawing
- ② Recommended spare parts
- ③ One set consists of one each of the shims listed immediately below marked
- ④ If replacing a bearing, output hub or a shaft, it is advisable to order a set of shims for adjustment of bearings on the shaft assembly. If replacing a housing, a set of shims should be ordered for each shaft assembly because the adjustment of bearings on each shaft assembly is affected.
- ⑤ Includes parts listed immediately below.
- ⑥ Parts marked make up the assemblies under which they are listed

Parts For SCXT325 MIMA Reducer

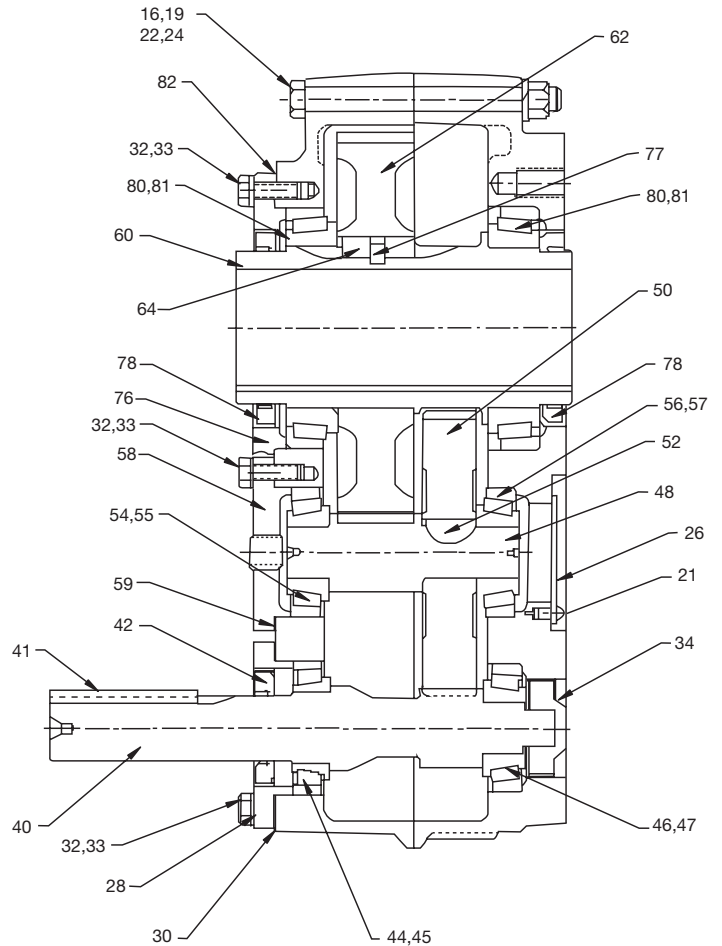

Dodge Industrial, Inc.
 1061 Holland Road
 Simpsonville, SC 29681
 +1 864 297 4800

