

DODGE ISAF Bearings Hydraulic Mount Patent # 7,866,894

Instruction and Lubrication Manual

These instructions must be read thoroughly before installation or operation. This instruction manual was accurate at the time of printing. Please see dodgeindustrial.com for updated instruction manuals.

WARNING: To ensure the drive is not unexpectedly started, turn off and lock-out or tag power source before proceeding. Failure to observe these precautions could result in bodily injury.

WARNING: All products over 25 kg (55 lbs) are noted on the shipping package. Proper lifting practices are required for these products.

INSPECTION

Inspect shaft to ensure it is smooth, straight, clean and within commercial tolerances. All weight must be removed from the shaft prior to installing.

TOOLS REQUIRED FOR PROPER INSTALLATION AND REMOVAL

- Hydraulic Hand Pump, Hose and Fluid
- 1/4 - 18 NPT Fitting
- 0-5000 psi Pressure Gauge for Hydraulic Pump
- M6 Allen Wrench
- Magnetic Base Dial Indicator
- Torque Wrench with Appropriate Socket (See Table 3)
- Drift and Hammer
- Rubber Mallet
- Hand File
- Adjustable Wrench
- 1/2 inch diameter Barring Rods (2), approximately 8" in length

WARNING: Because of the possible danger to person(s) or property from accidents which may result from the improper use of products, it is important that correct procedures be followed. Products must be used in accordance with the engineering information specified in the catalog. Proper installation, maintenance and operation procedures must be observed. The instructions in the instruction manuals must be followed. Inspections should be made as necessary to assure safe operation under prevailing conditions. Proper guards and other suitable safety devices or procedures as may be desirable or as may be specified in safety codes should be provided, and are neither provided by Dodge nor are the responsibility of Dodge. This unit and its associated equipment must be installed, adjusted and maintained by qualified personnel who are familiar with the construction and operation of all equipment in the system and the potential hazards involved. When risk to persons or property may be involved, a holding device must be an integral part of the driven equipment beyond the speed reducer output shaft.

MOUNTING PROCEDURE

NOTE: Misalignment must be within $\pm .1/2^\circ$.

Install Non-Expansion (Fixed) Bearing First

1. Remove lubricatable auxiliary seals from OD of Mount and Dismount Nuts. Be careful not to damage the two O-rings in bore of seal. Note orientation of seal.
2. Remove lock clip located on the face of the Mount Nut.

NOTE: The face of the Mount Nut contains 7 sets of equally spaced drilled and tapped holes and an instruction plate. The Dismount Nut contains three sets of drilled and tapped holes located 120° apart.

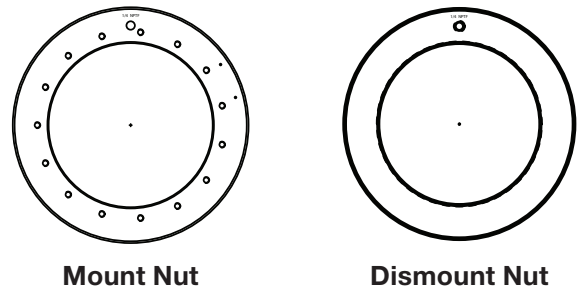

Figure 1 - Mount Nut and Dismount Nut

3. Scribe a line on Adapter face and Dismount Nut.
4. Rotate Dismount Nut counter clockwise two full rotations. The Dismount Nut must remain loose during the mounting procedure but should never be removed. Without loosening the dismount nut, the dismount unit piston will make contact with the bearing unit as it travels up the adapter. (See Figure 3) This will not allow the bearing to move up the adapter and tighten properly.
5. Rotate Mount Nut counter clockwise one full rotation and tap on the face with a rubber mallet. This will drive the adapter toward the Dismount Nut end and ensures the Adapter is fully expanded.
6. Slide one lubricatable auxiliary seal on shaft in same orientation as when it was removed.
7. Slide bearing on shaft and into position. If bearing will not slide onto the shaft repeat Step 5.
8. Using a spanner or barring rod rotate Mount Nut clockwise until snug. This allows the mount nut piston to be in full contact with the bearing unit so that when the mount nut is pressurized with hydraulic fluid, the piston will push the bearing unit up the adapter and properly tighten.

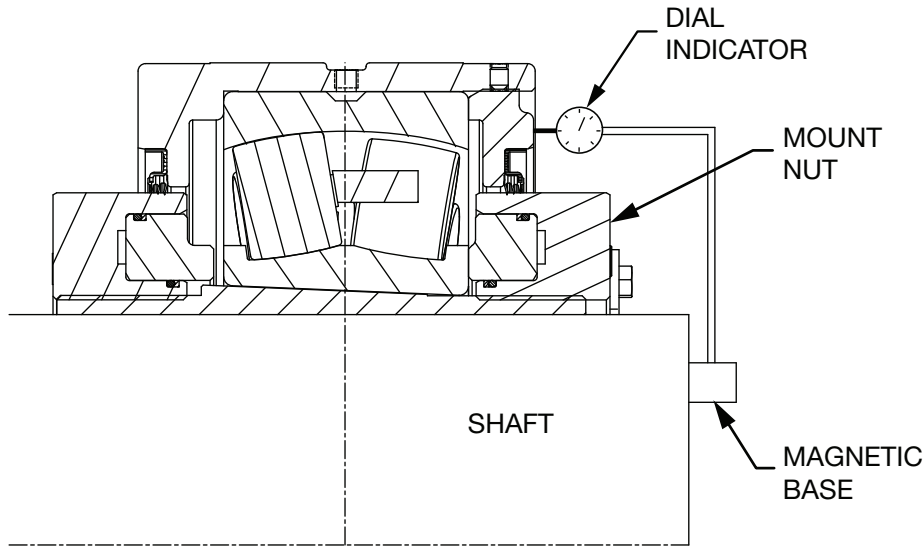

Figure 2 - Magnetic Base Indicator Placement

Table 1 - Starting Position Pressure

Bearing Series	Bore	Starting Position	Final Position	Recommended Shaft Tolerances
		(psi)	(in.)	
22232	5-7/16" - 5-1/2"	200	0.036	+0.000 -0.005
22234	5-15/16" - 6"	220	0.038	
22236	6-7/16" - 6-1/2"	210	0.04	+0.000 -0.006
22238	6-15/16" - 7"	200	0.042	
22244	7-1/2" - 8"	250	0.049	
23048	8-7/16" - 9"	210	0.05	
23056	9-15/16" - 10-1/2"	240	0.057	+0.000 -0.007
23060	10-15/16" - 11"	210	0.061	
23068	12-7/16" - 12-1/2"	240	0.069	+0.000 -0.008
23076	13-15/16" - 4"	225	0.076	
23080	15"	250	0.08	
23152	9-7/16" - 9-1/2"	430	0.054	+0.000 -0.007
23156	10" - 10-1/2"	400	0.058	
23160	10-15/16" - 11"	345	0.062	+0.000 -0.008
23164	11-15/16" - 12"	390	0.066	
23168	12-7/16" - 12-1/2"	440	0.071	
23172	13-7/16" - 13-1/2"	435	0.075	
23176	13-15/16" - 14"	400	0.078	

9. Attach a hydraulic pump to either of the two 1/4 - 18 NPT Fitting hydraulic ports found on the Mount Nut. They contain pipe plugs and are located on the face and OD of the nut 180° apart.
10. Actuate hydraulic pump until Starting Position Pressure (Table 1) is attained.
11. Install a magnetic base indicator or displacement gauge.
 - Displacement Gauge: Install gauge in hydraulic port on face of Mount Nut. Follow instructions included with gauge for proper installation.
 - Magnetic Base Indicator: Place on the shaft with the anvil on face of inner unit as shown in Figure 2.
12. Zero the Indicator.
13. Actuate hydraulic pump until indicator indicates movement as shown in the final position column of Table 1. Periodically check the dismount nut to ensure that it is still loose during the mounting process.

NOTE: If hydraulic pressure reaches 3,000 psi prior to attaining Final Position, abort procedure by releasing pressure to hydraulic nut. Check to ensure Dismount Nut is still loose. If not, rotate it counter clockwise 1 full rotation and repeat Step 13.

14. Remove Indicator from shaft or displacement gauge from mount nut.
15. **Release pressure to hydraulic pump and rotate Mount Nut clockwise until snug. This forces the hydraulic fluid back into the pump. Failure to complete this step may result in the locknut loosening during operation after it is tightened.**
16. Remove hydraulic attachment from Mount Nut and insert supplied pipe plug.
17. Using a spanner or drift and hammer, drive the Mount Nut clockwise until the lock clip can be inserted into one of the adapter slots and aligned with the drilled and tapped lock clip holes.

NOTE: Always tighten, never loosen, the Mount Nut.
18. Insert lock clip and tighten lock clip bolts.
19. Using a barring rod, rotate Dismount Nut clockwise until snug.
20. Align one of the set screws with the slot in the adapter. Rotate the dismount nut COUNTER CLOCKWISE if necessary until a set screw engages the slot.
21. Tighten the set screw to 110 ft-lbs.
22. Place the stabilizing ring over Mount Nut.
23. Install the lubricatable auxiliary seals onto the Mount and Dismount Nuts. Ensure all burrs or sharp edges are filed off the shaft, so that the o-rings in the seals are not damaged.

Install the Expansion (Float) Bearing

1. Follow the same steps as outlined for the Non-Expansion bearing.
2. Skip Step 22 since the stabilizing ring is not needed.

NOTE: Once the bearing is properly mounted, ensure the anti-rotation plug is positioned so that it is aligned with the machined groove in the cap housing. See Figure 3.

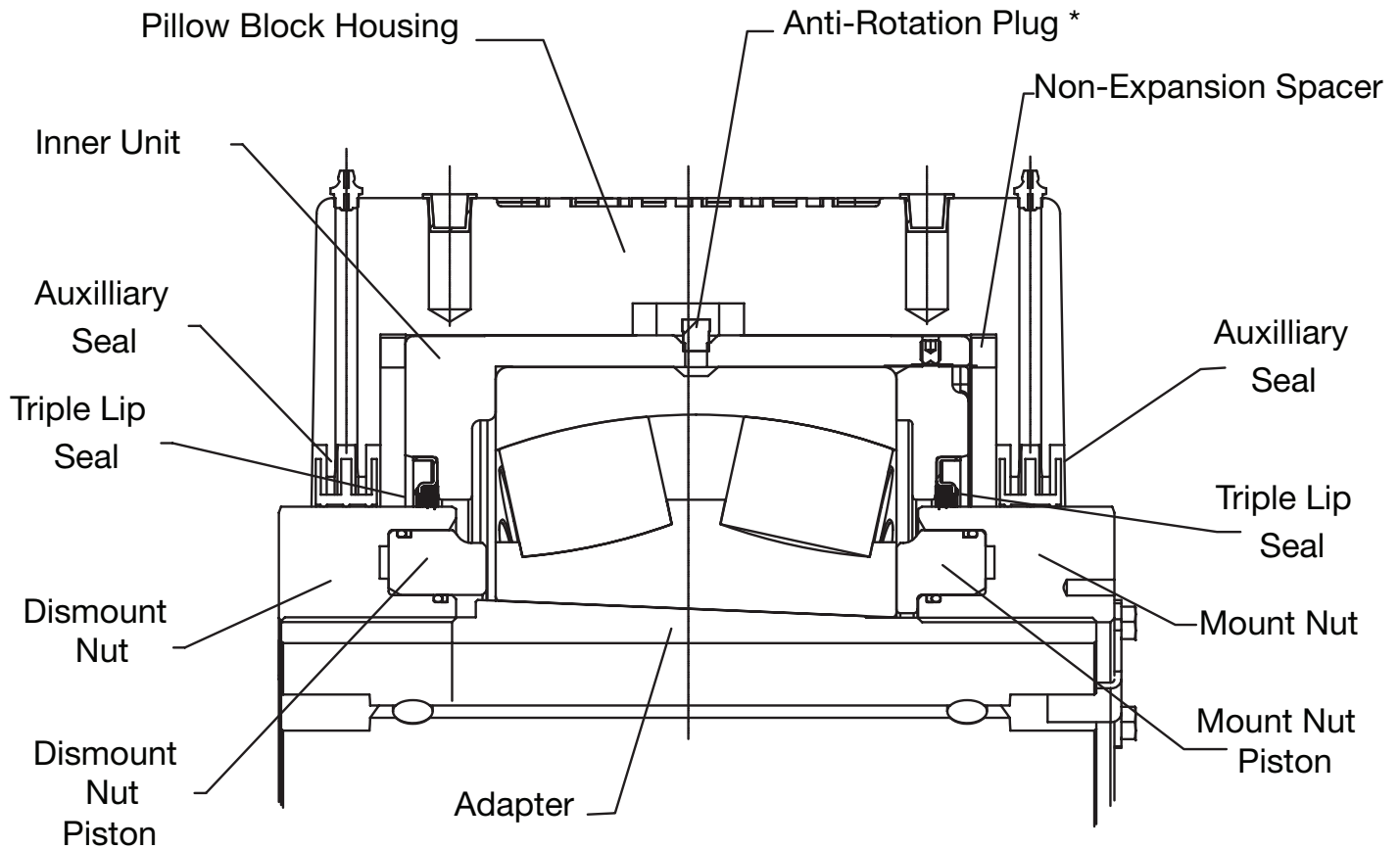

Figure 3 - Cross Section

DISMOUNT PROCEDURE

1. Remove lock clip from the Mount nut and loosen the set screw on dismount nut.
2. Remove lubricatable auxiliary seal from OD of Mount and Dismount Nuts. Be careful not to damage the two O-rings in bore of seal. Remove weight from shaft.
3. Scribe a line on the Adapter face and Mount Nut.
4. Incorporating a spanner or drift and hammer, rotate the Mount Nut counter clockwise two full rotations. The Mount Nut must remain loose during the dismounting procedure, but should never be removed. Without loosening the mount nut, the mount nut piston will make contact with the bearing unit as it travels down the adapter. (See Figure 3) This will not allow the bearing to move down the adapter and loosen from the shaft properly.
5. Using a spanner or barring rod, rotate the Dismount Nut clockwise until snug. This allows the dismount nut piston to be in full contact with the bearing unit so that when the dismount nut is pressurized with hydraulic fluid, the piston will push the bearing unit down the adapter and properly loosen from the shaft.
6. Attach the hydraulic pump to either of two supplied 1/4 - 18 NPT hydraulic ports found on Dismount Nut. The hydraulic ports contain pipe plugs and are located on the face and OD of the nut 180° apart.
7. Actuate the hydraulic pump until the pressure reading rises for initial break away load then decreases to zero. This will require repeated actuation of the pump. Once the pressure reaches zero, the bearing has been fully dismantled. Periodically check the mount nut to ensure that it is loose during the dismantling process.

NOTE: If hydraulic pressure reaches 3,000 psi, abort procedure by releasing pressure to the hydraulic pump. Check to ensure the Mount Nut is still loose. If not, rotate it counter clockwise 1 full rotation and repeat Step 5.

8. Release pressure to the hydraulic pump and rotate Dismount Nut in the clockwise position until snug. This forces the hydraulic fluid back into the pump.

LUBRICATION INSTRUCTIONS

Kinds of Grease: Dodge ISAF Unitized Spherical roller bearings are prepacked with NLGI #2 lithium complex grease. For re-lubrication, select a grease that is compatible with #2 lithium complex. The bearing housing is provided with zerk fittings over the seal grooves. Upon the initial start-up, when exposed to harsh environments, in the presence of dust, moisture or chemicals, it is best practice to grease each seal zerk to generate additional seal protection in the form of a grease dam. This seal area will permeate with additional grease as the bearing is routinely relubricated and the interior seals purge.

Special Operating Conditions: Refer acid, chemical, extreme or other special operating conditions to Mechanical Power Transmission Support in Greenville, SC.

Successful operation is dependent upon adequate lubrication. Precaution should be taken during handling and recycling grease, oil, or water glycol mixtures.

Table 2 - Lubrication Guide in Months				
Bore (in)	1-250 rpm	251-500 rpm	501-750 rpm	751-1000 rpm
5-7/16 - 5-1/2	1.5	1	0.5	0.25
5-15/16 - 7	1	0.5	0.5	0.25
8 - 9-1/2	1	1	0.5	---
10 - 12-1/2	1	0.5	---	---
13-15/16 - 15	0.5	0.25	---	---

Based on 12 hours/day, 150°F Max.
Continuous operation, 24 h/d, decrease by 50%.

Table 3 - Cap Bolt Torque 222xx + 230xx		
Shaft Diameter (in)	Cap Bolt Size	Torque (ft-lbs)
5-7/16 – 5-1/2	7/8	450
5-15/16 – 6-1/2	1	640
6-15/16 – 10-1/2	1-1/4	1120
10-15/16 – 11	1-1/2	1943
12-7/16 – 14	1-3/4	2290
14-15/16 – 15	2	3440

Table 4 - Cap Bolt Torque - Bearing 231XX Series		
Shaft Diameter (in)	Cap Bolt Size	Torque (ft-lbs)
9-7/16" - 9-1/2"	1-1/2	1943
10" - 10-1/2"	1-1/2	1943
10-15/16" - 11"	1-1/2	1943
11-15/16" - 12	1-3/4	2290
12-7/16" - 12-1/2"	2	3440
13-7/16" - 13-1/2"	2	3440
13-15/16" - 14"	2	3440

CHECK FOR ALIGNMENT

Alignment is critical for the Hydraulic ISAF bearing. The bearing has a misalignment capability of +/- 1/2°. Exceeding this value will cause the lubricatable auxiliary seal to interfere with the pillow block housing. Alignment of these bearings is a simple procedure. Using the same magnetic base dial indicator used in mounting the bearing, place the magnetic side on the shaft. Place the probe on the machined flat of the pillow block housing right above the lubricatable auxiliary seal at the 12 o'clock position. Zero out the indicator and rotate the shaft so that the probe is now at the 6 o'clock position. Record the readings from dial indicator. If the value is less than the value on Table 5, the bearing is aligned in the 12 to 6 o'clock position. Do the same procedures for the 3 to 9 o'clock position. If the reading

is outside the allowable misalignment, additional adjustment is needed on the housing. If the alignment is off in the 12 to 6 o'clock position, make sure the base that the bearing is mounted on is flat and free from any debris. Shims can be used, if needed, to assist with the flatness. If the bearing is misaligned in the 3 to 9 o'clock position, tapping on the pillow block in the correct direction will align the housing. After realigning the pillow block, sweep the face of the housing again in the same 12 to 6 o'clock and 3 to 9 o'clock positions to ensure alignment.

Table 5		
H-ISAF Maximum Misalignment Capability		
Bore Sizes (inches)	Housing Series	1/2° Misalignment *
5-7/16 5-1/2	532	.080
5-15/16 6	534	.085
6-7/16 6-1/2	536	.090
6-15/16 7	538	.090
7-15/16 8	544	.105
8-1/2 9	048	.105
10 10-7/16 10-1/2	056	.125
11	060	.130
12-1/2	068	.150
14	076	.160
15	080	.165
9-7/16 9-1/2	3152	.110
10 10-7/16 10-1/2	3156	.120
10-15/16 11	3160	.130
11-15/16 12	3164	.140
12-7/16 12-1/2	3168	.145
13-7/16 13-1/2	3172	.155
13-15/16 14	3176	.160

* The difference in inches between the depth micrometer and dial indicator measurements needs to fall within these values to be aligned.

Dodge Industrial, Inc.
1061 Holland Road
Simpsonville, SC 29681
+1 864 297 4800

