



DODGE COOL LUBE 2 for Mounted Roller Bearings

Part Numbers 063485, 063486, 078327, 078328

These instructions must be read thoroughly before installation or operation. This instruction manual was accurate at the time of printing. Please see dodgeindustrial.com for updated instruction manuals.

WARNING: To ensure the drive is not unexpectedly started, turn off and lock-out or tag power source before proceeding. Failure to observe these precautions could result in bodily injury.

WARNING: All products over 25 kg (55 lbs) are noted on the shipping package. Proper lifting practices are required for these products.

WARNING: Only qualified personnel familiar with hydraulic and electrical installations, the construction and operation of this equipment, and the hazards involved should install, adjust, operate, and/or service it. Read and understand this manual in its entirety before proceeding. Failure to observe this precaution could result in severe bodily injury or loss of life.

WARNING: Because of the possible danger to person(s) or property from accidents which may result from the improper use of products, it is important that correct procedures be followed. Products must be used in accordance with the engineering information specified in the catalog. Proper installation, maintenance and operation procedures must be observed. The instructions in the instruction manuals must be followed. Inspections should be made as necessary to assure safe operation under prevailing conditions. Proper guards and other suitable safety devices or procedures as may be desirable or as may be specified in safety codes should be provided, and are neither provided by Dodge nor are the responsibility of Dodge. This unit and its associated equipment must be installed, adjusted and maintained by qualified personnel who are familiar with the construction and operation of all equipment in the system and the potential hazards involved. When risk to persons or property may be involved, a holding device must be an integral part of the driven equipment beyond the speed reducer output shaft.

System Specifications:

System Part Number	Motors Information	Approximate Weights (lbs.)
063486	Single Phase—115/230 VAC	257
063485	Three Phase—230/460 VAC	257
078327	Three Phase—208-230/460 VAC (Explosion Proof Motors)	257
078328	Three Phase—575 VAC (Canada)	257

Note: For Cool Lube 2 material details, please refer to cut sheets.

Air to oil heat exchanger:	Thermal Transfer BOL-8-2
* Pump Relief valve setting:	150 psi
* Bearing Relief valve setting:	65 psi
Pump flow rate:	2 GPM
Flow meter range:	0.05 – 0.5 GPM
Oil supply line connection:	Two 1/4" NPT connections at the flow meter outlets (female)
Oil return line connection:	Two 1" NPT connections (female)

* Relief valves are preset at the factory, but are field adjustable. If other settings are required, consult Dodge Engineering

Receiving & Inspection:

1. Carefully unpack the Cool Lube 2 system. Inspect the system for any damage during shipping.
2. Report any damage to the carrier for claims.
3. Make sure that available voltage supply is within 10% of the system voltage.
4. Check all hydraulics to ensure that nothing came loose during shipping. Tighten as needed.
5. Changes to this unit may void the warranty.

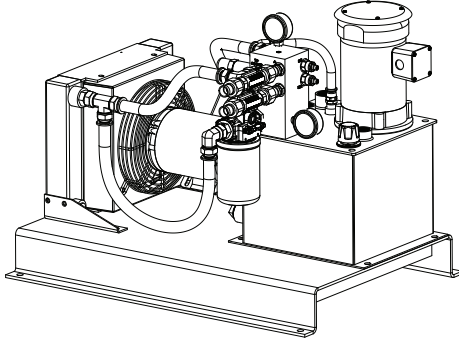

Figure 1 - Cool Lube 2

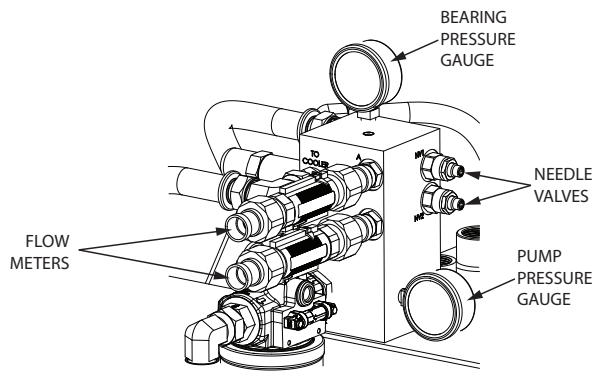

Figure 2 - Controls

Installation Instructions:

1. Place the unit in the designated area and anchor it down using the 4 mounting holes in the base plate. The unit should be positioned below the circulating oil drain holes in the bearings so that at least a 15° drain line slope is achieved to allow for adequate oil return.
2. Make sure that there is enough space around the unit to allow for servicing.
3. Connect oil supply lines (not included) from the two 1/2" NPT (female) outputs of the flow meters to the circulating oil inlets on the housings.
4. Connect oil return lines (not included) from the circulating oil drain holes in the bearing housings to the 1" NPT (female) returns on the Cool Lube 2 reservoir.

NOTE: All plumbing should be cleaned and flushed before being connected to the bearings.

NOTE: Drain piping should be vented and as large as possible to drain oil from the bearings at the same rate as the incoming oil flow. The circulating oil drains must be directed straight down into a return drain sloping away at a 15° or greater angle.

5. Fill up the Cool Lube 2 reservoir with clean oil by monitoring the oil level gauge on the tank. The reservoir will hold 5 gallons of oil.

Electrical Hook Up:

Connect the two electric motors to a power supply through the proper fuses, starters and overload protection using NEC and local electrical codes.

Optional Heater/Thermostat Assembly:

260W X 120V, 1 PH—Part # 434725

260W X 240V, 1 PH—Part # 434726

Optional Temperature/Oil Level Switch:

Part # 434941. Connects to a control system (not provided by Dodge) in order to monitor oil level and temperature.

Replacement Filter:

Use replacement oil filter Part # 078358

Optional Filter Additions:

- Duplex filter head with two filters
- Water absorbing filter with moisture absorbing capability can be added in series after the standard filter.

Operating Instructions:

1. Observe the oil level gauge on the tank to ensure that oil is at the proper level.
2. Quickly jog both motors on and off to see if they are rotating in the correct directions (reference the rotation arrows on top of the motors). Correct the wiring if necessary. (Reverse direction will cause damage to the pump.)
3. Before starting the Cool Lube 2, jog the pump motor four or more times to prime the pump.
4. Start the Cool Lube 2 and allow the oil to circulate. Be sure to monitor the oil level in the tank to ensure that the oil returns from the bearing housings. If air in the return lines becomes a problem, it may be necessary to bleed the air out of the lines by loosening a fitting close to where the problem is.
5. Visually check the system for leaks and correct if necessary.
6. Confirm that there is flow by using the flow meters. If there is no flow, check for leaks.
7. Adjust the oil flow rates to desired flow by adjusting the needle valves while observing the flow meters (See Figure 2). To adjust the needle valves, first loosen the locknut, then use an Allen wrench to open and close the valves. Make sure that the pump pressure does not exceed 200 psi by watching the system pressure gauge.
8. Make sure there are no leaks of any kind.
9. Turn off the pump.
10. Check oil level in the tank. The oil level will go down as the oil fills the bearing lines. If the lines are lengthy, additional oil may be needed to restore the proper level.
11. Once the flows to the bearings are confirmed, the unit is ready for operation.
12. Monitor the pressure gauges and oil level closely the first few hours of operation.
13. To change the filter while the unit is running, pull and rotate the filter bypass valve 90°.

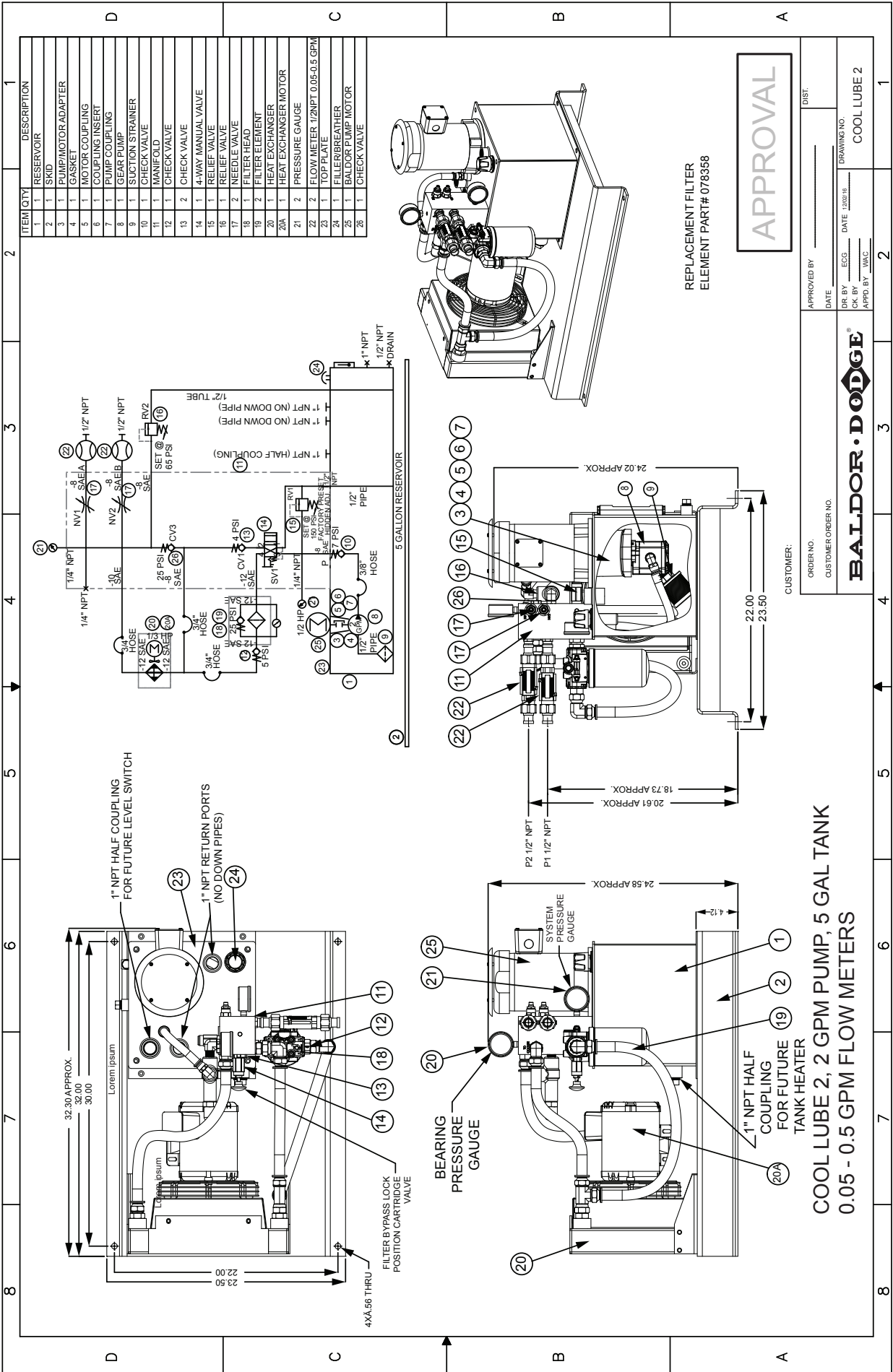

ITEM	QTY	DESCRIPTION
1	1	RESERVOIR
2	1	SKID
3	1	PUMP/MOTOR ADAPTER
4	1	GASKET
5	1	MOTOR COUPLING
6	1	COUPLING INSERT
7	1	PUMP COUPLING
8	1	GEAR PUMP
9	1	SUCTION STRAINER
10	1	CHECK VALVE
11	1	MANIFOLD
12	1	CHECK VALVE
13	2	CHECK VALVE
14	1	4-WAY MANUAL VALVE
15	1	RELIEF VALVE
16	1	RELIEF VALVE
17	2	NEEDLE VALVE
18	1	FILTER HEAD
19	2	FILTER ELEMENT
20	1	HEAT EXCHANGER
20A	1	HEAT EXCHANGER MOTOR
21	2	PRESSURE GAUGE
22	2	FLOW METER 1/2NPT 0.05-0.5 GPM
23	1	TOP PLATE
24	1	FILLER/BREATHER
25	1	BALDOR PUMP MOTOR
26	1	CHECK VALVE

APPROVAL

REPLACEMENT FILTER
ELEMENT PART# 078358

APPROVED BY: _____ DATE: _____

DR. BY: ECG DATE: 2/20/16

APPR. BY: MAC

DIST. _____

BALDOR • DODGE®

CUSTOMER ORDER NO. _____

CUSTOMER: _____

ORDER NO. _____

DATE: _____

DRAWING NO. _____

COOL LUBE 2

COOL LUBE 2, 2 GPM PUMP, 5 GAL TANK
0.05 - 0.5 GPM FLOW METERS

Hydraforce RV08-20H-0-N5/.75

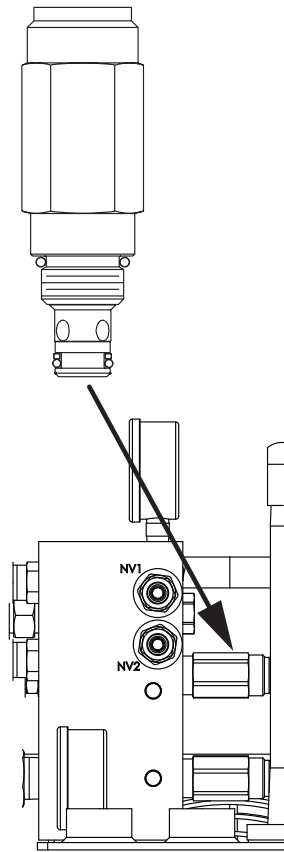

Fulflo VJ-3R/HS/WS

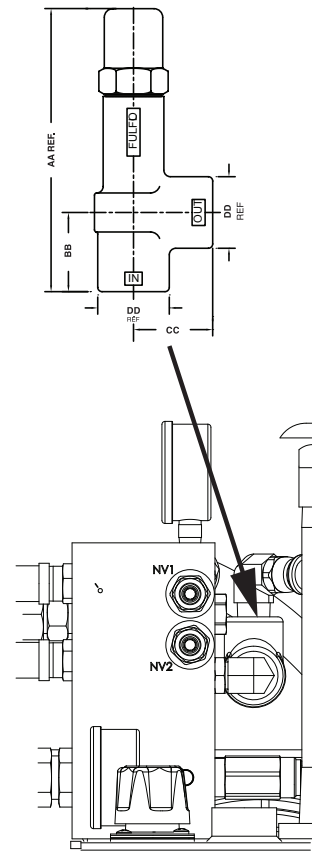

Figure 3 - Relief Valves

Maintenance:

Periodically check the oil level in the bearing housings and the Cool Lube 2 to ensure proper operation.

Most foreign material in a system flushes to the reservoir after the first few hours of operation. We recommend that you drain the tank, replace the fluid, change the filter, and clean the suction strainer after 3-5 hours of operation. After the initial cleaning, the strainer should be cleaned at a minimum of every 4000 hours of operation. More frequent cleaning is required if the system is used in a highly contaminated atmosphere such as a foundry or paper mill.

After the initial replacement, the supply line filter should be replaced periodically as required by operating conditions. Check the visual clog indicator on the filter head between filter changes to ensure the filter is not being bypassed.

Good preventative maintenance is the best insurance against unscheduled downtime. Unscheduled downtime is usually more expensive than preventive maintenance.

NOTE: Cool Lube 2 units manufactured after September 2016 utilize a new relief valve for the pressure line only.

Previous Relieve Valve: Hydraforce RV08-20H-0-N-5/.75

New Relief Valve: Fulflo VJ-3R/HS/WS

For Cut Sheets of each valve, contact manufacturers.

Dodge Industrial, Inc.
1061 Holland Road
Simpsonville, SC 29681
+1 864 297 4800

