



TXT-SCXT BELT GUARD INSTALLATION MANUAL

These instructions must be read thoroughly before installation or operation. This instruction manual was accurate at the time of printing. Please see dodgeindustrial.com for updated instruction manuals.

WARNING: To ensure the drive is not unexpectedly started, turn off and lock-out or tag power source before proceeding. Failure to observe these precautions could result in bodily injury.

WARNING: All products over 25 kg (55 lbs) are noted on the shipping package. Proper lifting practices are required for these products.

WARNING: Ensure that all guards are properly installed before proceeding. Exercise extreme care to avoid contacting rotating parts. Failure to observe these precautions could result in bodily injury.

WARNING: Because of the possible danger to person(s) or property from accidents which may result from the improper use of products, it is important that correct procedures be followed. Products must be used in accordance with the engineering information specified in the catalog. Proper installation, maintenance and operation procedures must be observed. The instructions in the instruction manuals must be followed. Inspections should be made as necessary to assure safe operation under prevailing conditions. Proper guards and other suitable safety devices or procedures as may be desirable or as may be specified in safety codes should be provided, and are neither provided by Dodge nor are the responsibility of Dodge. This unit and its associated equipment must be installed, adjusted and maintained by qualified personnel who are familiar with the construction and operation of all equipment in the system and the potential hazards involved. When risk to persons or property may be involved, a holding device must be an integral part of the driven equipment beyond the speed reducer output shaft.

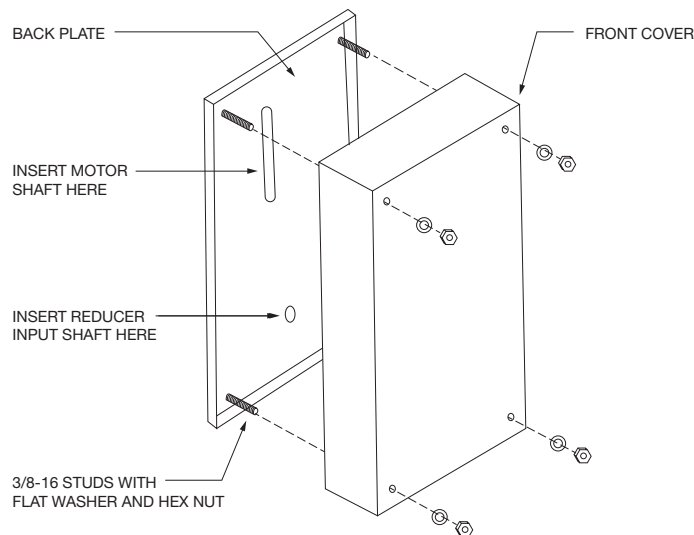

INSTALLATION:

1. Remove belt guard and attaching hardware from box and ensure all parts are available.
2. Remove the front cover by removing the nuts from the four corner studs. Position back section over the motor and reducer shafts.
3. The guard has four mounting straps. Attach the lower straps to the corresponding housing assembly bolts.
4. Attach the two upper straps to the holes provided on the front motor mount support.
5. Install sheaves and belts and adjust accordingly.
6. Install front cover over four corner mounting studs, secure with nuts and washers provided.
7. Check operation of machine.

Dodge Industrial, Inc.
1061 Holland Road
Simpsonville, SC 29681
+1 864 297 4800

