

Dodge® Type E, K, Double-Interlock and TAF End Closure Mounting Procedure and E-Tect Seals Instruction Manual

These instructions must be read thoroughly before installation or operation. This instruction manual was accurate at the time of printing. Please see dodgeindustrial.com for updated instruction manuals.

WARNING: To ensure the drive is not unexpectedly started, turn off and lock-out or tag power source before proceeding. Failure to observe these precautions could result in bodily injury.

WARNING: All products over 25 kg (55 lbs) are noted on the shipping package. Proper lifting practices are required for these products.

TYPE E, K, DOUBLE-INTERLOCK AND TAF END CLOSURE MOUNTING PROCEDURE

NOTE: To use end closures with Dodge Type E, a field modification must be done to the bearing.

Prior to Installing Bearing to Shaft (For Type E End Closures Only - Table 1):

1. Remove and discard the collar on the side that will receive the end closure.
2. Using a sharp point rod, pierce through the seal of the bearing on the side that the collar was removed. Do this carefully so as not to damage the retainer of the bearing. After piercing the seal, pry it out and discard.
3. Install the new collar on the bearing and refer to instruction manual for set screw installation torque.

Installing Bearing and End Closure (For All Type E Family End Closures - Tables 1 and 2):

1. Mount the bearing on the shaft with the end receiving the end closure facing towards the shaft end. The shaft end should be flush with the bearing end.
2. Torque collar set screws to appropriate torque values.
3. Tighten base bolts and insure the system is aligned.
4. For sizes up to 5", guide the end closure over the collar and into the housing bore. (Figure 1 or 2). Hold a piece of wood wide enough to cover the entire end closure face against the face of the end closure. Using a mallet, strike against wood to drive the end into the housing. The end closure is securely mounted when the ridge on the OD of the end closure bottoms against the housing. For Double Interlock, Type-K, and TAF over 5", screws are used to attach the cover. See Figure 3.

WARNING: Because of the possible danger to person(s) or property from accidents which may result from the improper use of products, it is important that correct procedures be followed. Products must be used in accordance with the engineering information specified in the catalog. Proper installation, maintenance and operation procedures must be observed. The instructions in the instruction manuals must be followed. Inspections should be made as necessary to assure safe operation under prevailing conditions. Proper guards and other suitable safety devices or procedures as may be desirable or as may be specified in safety codes should be provided, and are neither provided by Dodge nor are the responsibility of Dodge. This unit and its associated equipment must be installed, adjusted and maintained by qualified personnel who are familiar with the construction and operation of all equipment in the system and the potential hazards involved. When risk to persons or property may be involved, a holding device must be an integral part of the driven equipment beyond the speed reducer output shaft.

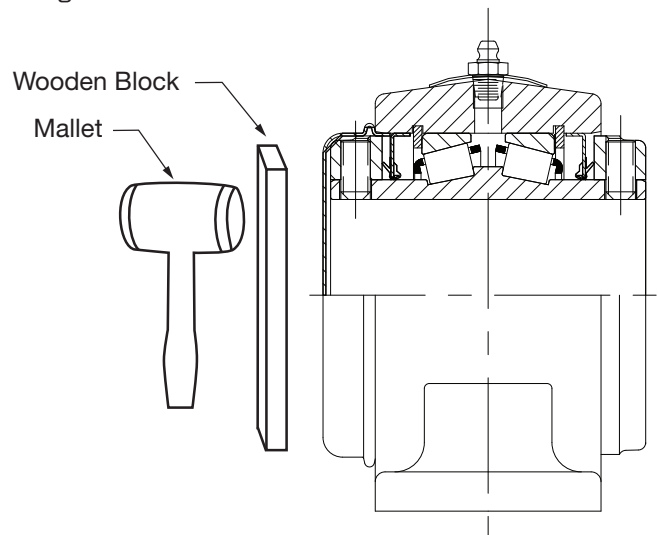

Figure 1 - Type E

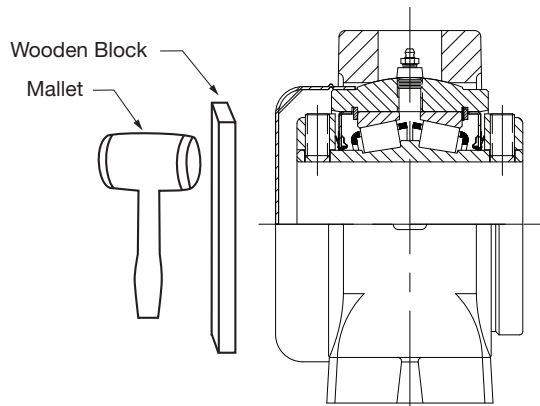

Figure 2 - 1-7/16" to 5" Type K, Double-Interlock, and TAF

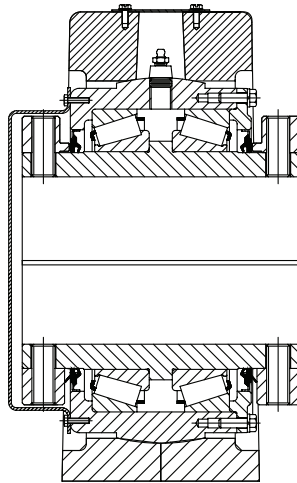

Figure 3 - Double-Interlock Type K and TAF over 5"

Table 1—End Closure Kit Numbers Used with Dodge Type E Mounted Units

Shaft Size	Kit No.
1-3/16 — 1-1/4	023795
1-3/8 — 1-7/16	023796
1-1/2 — 1-11/16	023797
1-3/4 — 2	023798
2-3/16	023799
2-1/4 — 2-1/2	023800
2-11/16 — 3	023801

NOTE: Includes End Closure and Special Collar

Table 2—End Closure Numbers used with Dodge Double-Interlock, K and TAF Mounted Units

Shaft Size	Kit No.
1-3/8 — 1-7/16	037681
1-1/2 — 1-11/16	037682
1-3/4 — 2	037683
2-3/16	037684
2-1/4 — 2-1/2	037685
2-11/16 — 3	037686
3-3/16 — 3-1/2	037687
3-15/16 — 4	037688
4-7/16 — 4-1/2	037689
4-15/16 — 5	037690
5-7/16 — 6	141152
6-7/16 — 7	141153

NOTE: Includes End Closure Only

E-TECT SEALS ASSEMBLY PROCEDURE

Assembly of E-Tect (Auxiliary Seal) seals used with E-Family bearings (E, K, DI & TAF). The E-Tect seal is used as a supplementary seal to the Dodge E-Family bearings with "R" seals in extremely harsh environments at speeds up to 75% of catalog maximum speed.

The E-Tect Seal Kit up to 5" bore consists of a special collar, V-ring seal and two or more cup point set screws. The set screws have different lengths. For a specific bore size, a specific length set screw must be selected per Table 3. Above 5" bore, the kit consists of a modified V-ring seal.

Installation Steps for up to 5" Bore:

1. Remove standard collar (1) from bearing cone (2) by backing off the two standard set screws (3) past the outside diameter of bearing cone (4) then pull on the collar until it slides off the cone.
2. Mount V-ring seal (5) on the special collar supplied with the seal kit. Do not install set screws on the collar (6) at this time. Stretch and mount the V-ring seal tightly against the special collar machined shoulder. V-ring seal lip facing away from shoulder. Apply grease to the V-ring Seal body and lip.
3. Slide special collar and V-ring seal assembly on the bearing cone. Make sure V-ring seal lip locates against the face of the existing seal stamping in the bearing.
4. Align the two holes at the end of the bearing cone with the set screw holes in the special collar. Thread the correct length set screw (see Table 3) up into the collar starting from the bore of the bearing cone for sizes smaller than 3-3/16 shaft size. For the larger shaft sizes thread the correct length set screw from the outside diameter of the special collar. Thread the set screws until they just clear the bore of the bearing Cone (7).
5. Repeat steps 2, 3 and 4 for the opposite side of the bearing if an E, DI or TAF bearing. Type K bearing has only one collar. Type E piloted flanges up to 3-1/2 bore are also fitted with only one collar.
6. Rotate the bearing cone to insure that the seals are not binding and are seated properly against collar shoulder.
7. The bearing fitted with E-Tect seals or seal is now ready to be mounted on the shaft. Follow the appropriate instruction manual.

Installation Steps for Over 5" Bore:

1. Remove standard collar (1) from bearing cone (2) by backing off the two standard set screws (3) past the outside diameter of bearing cone (4) then pull on the collar until it slides off the cone.
2. Slide special V-ring seal on the outside diameter of the bearing cone until the V-ring seal lip contacts existing seal face.
3. Reinstall collar previously removed under step 1.
4. Rotate the bearing cone to insure that the seal is not binding and is seated properly against collar.
5. Repeat steps 1-4 for the opposite side if applicable.

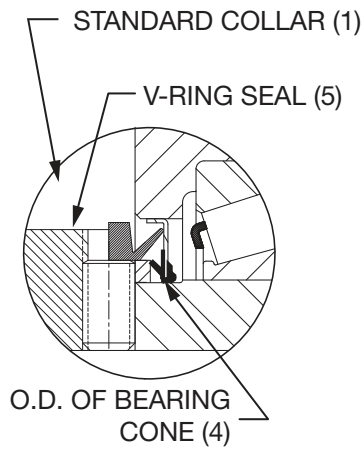

Standard "R" Seal

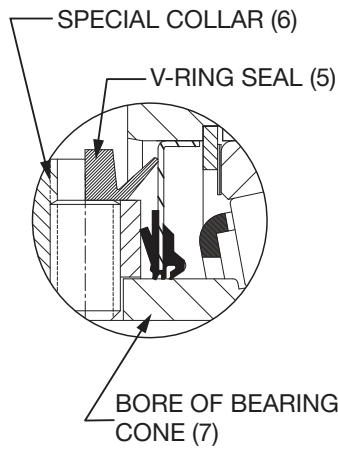

**E-Tect Seal
1-3/16" through 5"**

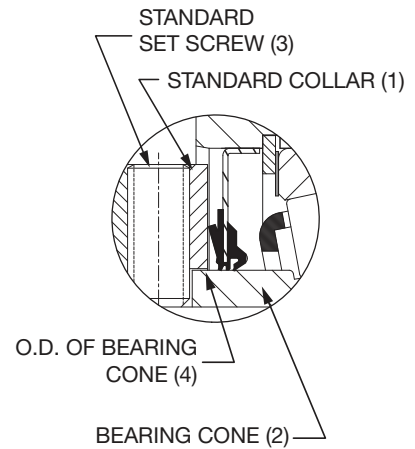

**E-Tect Seal
5-7/16" through 7"**

Table 3-E-Tect Seals Kit Ordering Numbers and Parts Description

Resale P/N	Description	Comp. P/N	Quantity.	Description
037650	E-TECT SEAL KIT 103-104	040465	1	V-50AM V-RING
		037661	1	103 E-TECT COLLAR 65°
		400050	2	5/16 X 3/8 SSCP
037651	E-TECT SEAL KIT 106-107	042226	1	V-60A V-RING
		037662	1	107 E-TECT COLLAR 65°
		400277	2	5/16 X 7/16 SSCP
037652	E-TECT SEAL KIT 108-111	045994	1	V-70A V-RING
		037663	1	111 E-TECT COLLAR 65°
		400058	2	5/16 X 5/8 SSCP
		400054	2	5/16 X 1/2 SSCP
037653	E-TECT SEAL KIT 112-200	040466	1	V-75AM V-RING
		037664	1	115 E-TECT COLLAR 65°
		400090	2	3/8 X 5/8 SSCP
		400129	2	316 X 9/16 SSCP
		400086	2	3/8 X 1/2 SSCP
037654	E-TECT SEAL KIT 203	040467	1	V-85AM V-RING
		037665	1	203 E-TECT COLLAR 65°
		400129	2	3/8 X 9/16 SSCP
037655	E-TECT SEAL KIT 204-208	040468	1	V-90AM V-RING
		037666	1	207 E-TECT COLLAR 65°
		400090	2	3/8 X 5/8 SSCP
		400129	2	3/8 X 9/16 SSCP
037656	E-TECT SEAL KIT 211-300	040469	1	V-110AM V-RING
		037667	1	215 E-TECT COLLAR 65°
		400139	2	1/2 X 13/16 SSCP
		400146	2	1/2 X 3/4 SSCP
		400136	2	1/2 X 11/16 SSCP
037657	E-TECT SEAL KIT 303-308	040470	1	V-130AM V-RING
		037668	1	307 E-TECT COLLAR 65°
		400154	2	1/2 X 1 SSCP
037658	E-TECT SEAL KIT 315-400	040471	1	V-130AM V-RING
		037669	1	307 E-TECT COLLAR 65°
		400186	2	5/8 X 1 SSCP
037659	E-TECT SEAL KIT 407-408	040472	1	V-150AM V-RING
		037670	1	407 E-TECT COLLAR 65°
		400186	2	5/8 X 1 SSCP
037660	E-TECT SEAL KIT 415-500	040473	1	V-180AM V-RING
		037671	1	415 E-TECT COLLAR 65°
		400190	2	5/8 X 1-1/4 SSCP
037673	E-TECT SEAL KIT 507-600	040304	1	V-180A MOD - V-RING
037674	E-TECT SEAL KIT 607-700	040305	1	V-199A MOD - V-RING

Dodge Industrial, Inc.
1061 Holland Road
Simpsonville, SC 29681
+1 864 297 4800

