

INSTRUCTION MANUAL FOR DODGE® CHAIN TENSIONER FRAME

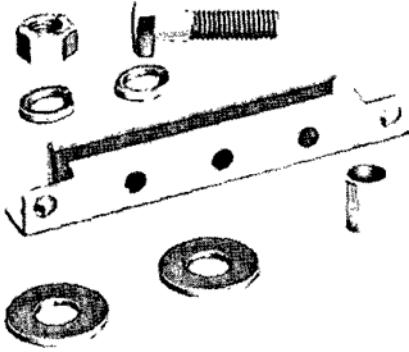

The chain tensioner frame may be mounted on surfaces parallel to or at 90° to the plane of the chain drive. Mounting is accomplished by using two 5/16" dia. bolts, provided by the user. Parallel surface mounting provides a full 4" of adjustment. Installation on a surface 90° to the chain drive, will limit adjustment to 2½" or 1½", depending on which intermediate mounting hole is used.

Refer to the assembly drawing on the back side of this sheet. When using an idler sprocket with a 5/8" bore, press the adapter into the bore of the sprocket to allow proper assembly on the ½" bolt.

Up to a 1/2" of washers may be used between the mounting surface and the bracket for spacing purposes, if necessary. Special adaptations must be made if the application requires greater spacing.

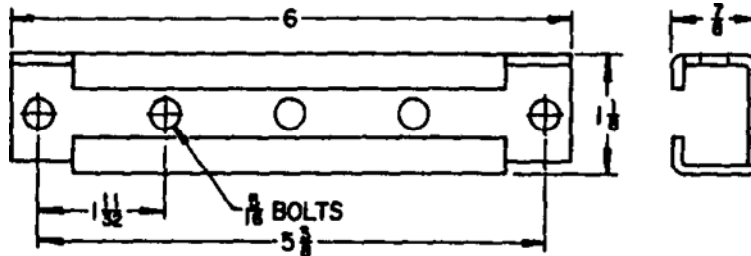

BALDOR

World Headquarters
P.O. Box 2400, Fort Smith, AR 72902-2400 U.S.A., Ph: (1) 479.646.4711, Fax (1) 479.648.5792, International Fax (1) 479.648.5895
Dodge Product Support
6040 Ponders Court, Greenville, SC 29615-4617 U.S.A., Ph: (1) 864.297.4800, Fax: (1) 864.281.2433
www.baldor.com

© Baldor Electric Company

MN4043
(Replaces 499659)



All Rights Reserved. Printed in USA.

06/30/09

Chain Pitch	Number of spacer washers to be used between bracket and bronze bushed Idler sprocket		Distance from mounting surface to centerline of sprocket
	Plain Washers	Lock Washers	
35, 40, 41, 2040	0	1	$1^{15}/_{32}$
50, 2050	1	1	$1^{19}/_{32}$
60, 60H, 2060	2	1	$1^{11}/_{16}$

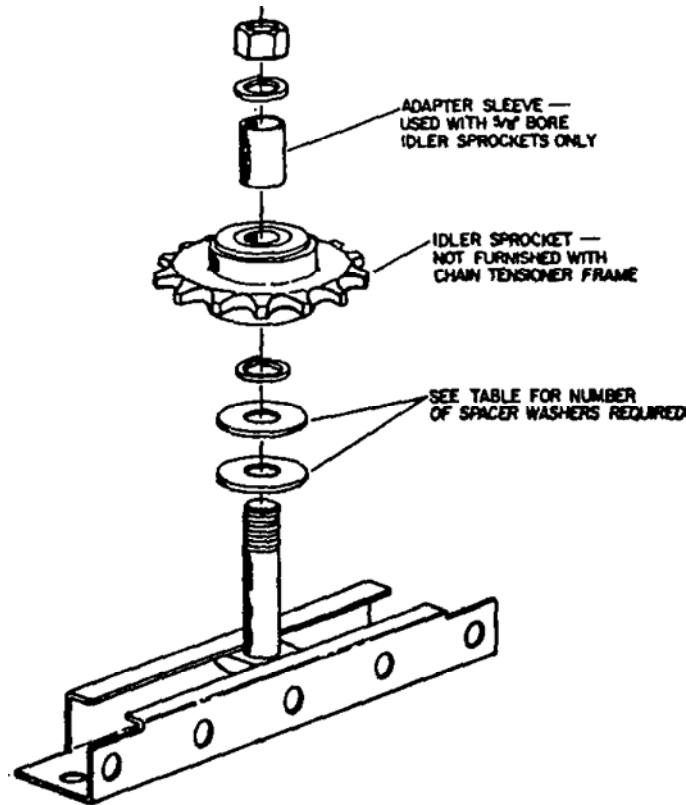

WARNING: Because of the possible danger to persons(s) or property from accidents which may result from the improper use of products, it is important that correct procedures be followed. Products must be used in accordance with the engineering information specified in the catalog. Proper installation, maintenance and operation procedures must be observed. The instructions in the instruction manuals must be followed. Inspections should be made as necessary to assure safe operation under prevailing conditions. Proper guards and other suitable safety devices or procedures as may be desirable or as may be specified in safety codes should be provided, and are neither provided by Baldor Electric Company nor are the responsibility of Baldor Electric Company. This unit and its associated equipment must be installed, adjusted and maintained by qualified personnel who are familiar with the construction and operation of all equipment in the system and the potential hazards involved. When risk to persons or property may be involved, a holding device must be an integral part of the driven equipment beyond the speed reducer output shaft.