



Dodge® Screw Conveyor and Hydroil Screw Conveyor Drive SCXT105 thru SCXT705 Single Reduction Screw Conveyor Drive HSCXT105 thru HSCXT505A Single Reduction Hydroil Screw Conveyor Drive

These instructions must be read thoroughly before installation or operation. This instruction manual was accurate at the time of printing. Please see dodgeindustrial.com for updated instruction manuals.

WARNING: To ensure the drive is not unexpectedly started, turn off and lock-out or tag power source before proceeding. Failure to observe these precautions could result in bodily injury.

WARNING: All products over 25 kg (55 lbs) are noted on the shipping package. Proper lifting practices are required for these products.

NOTE: A Screw Conveyor Drive consists of two subassemblies and drive shaft listed below.

1. **Reducer** – Includes speed reducer, shaft retainer, retainer bolt and lockwasher.
2. **Adapter Assembly** – Includes adapter bolts, lockwashers, a lip type seal, a seal retaining ring and drive shaft key.

Make certain none of the parts have been damaged in shipment. Any shipping damage should be promptly reported to the carrier. Read all instructions in this manual before attempting to assemble or install the Screw Conveyor Drive. It is important that assembly be performed in the following sequence and that each step be completed before continuing to the next.

WARNING: Because of the possible danger to person(s) or property from accidents which may result from the improper use of products, it is important that correct procedures be followed. Products must be used in accordance with the engineering information specified in the catalog. Proper installation, maintenance and operation procedures must be observed. The instructions in the instruction manuals must be followed. Inspections should be made as necessary to assure safe operation under prevailing conditions. Proper guards and other suitable safety devices or procedures as may be desirable or as may be specified in safety codes should be provided, and are neither provided by Dodge nor are the responsibility of Dodge. This unit and its associated equipment must be installed, adjusted and maintained by qualified personnel who are familiar with the construction and operation of all equipment in the system and the potential hazards involved. When risk to persons or property may be involved, a holding device must be an integral part of the driven equipment beyond the speed reducer output shaft.

NOTE: This reducer is compatible with the Dodge Ability Smart Sensor that can be installed in the adapter plug labeled “smart sensor”. The plug and sensor can be moved to different locations as required by mounting position.

ASSEMBLY

1. Place reducer on blocks so that it lays flat with the input shaft down.
2. Position adapter on reducer output hub so that small end (end with 12 holes) rests on reducer. Select the 4 mounting holes to match the shaft used (Figure 1).
3. Place adapter screws and lockwashers through adapter and thread into reducer. Do not tighten.
4. Place seal in adapter so that spring faces out. Seal should be tapped evenly into place in the adapter with a soft hammer, applying force only on the outer corner of the seal. Fill cavity between lips of seal with grease. Install seal retainer ring by tapping with a hammer. Apply grease to adapter section of shaft (middle section). Slide shaft, keyseated end first, into adapter and through reducer.

NOTE: Be extremely careful when sliding adapter section of shaft through seal to prevent seal lips from being damaged or rolled over.

5. Carefully place reducer on its side. Rotate shaft to align keyseats in shaft and output hub and install key. Install shaft retainer, lockwasher and bolt. Tighten bolt to torque specified in Table 4.
6. Lay reducer on blocks with input shaft down and tighten adapter bolts to torque specified in Table 4.
7. If waste packing is to be used, it may be installed through access hole provided in the adapter. Waste packing, not furnished with the screw conveyor drive, may be used as a separate seal option or in combination with the lip seal.

OPTIONAL ADJUSTABLE PACKING ADAPTER - ASSEMBLY

1. Place reducer on blocks so that it lays flat with the input shaft down.
2. Position adapter on reducer output hub so that small end (end with 12 holes) rests on reducer. Select the 4 mounting holes to match the shaft used (Figure 1).
3. Place adapter screws and lockwashers through adapter and thread into reducer. Do not tighten.
4. Install 2 screws in studs in the adapter. Use Loctite on threads. See Figure 2.

Flatten braided seals with a soft hammer. Place seals in adapter, one of top of the other with joints offset from each other. Lay retaining ring loosely on top of seals. Slide shaft, keyseated end first, into adapter and through adjusting flange into reducer. Take care to clear the seals with the adapter section of the shaft. Once shaft has bottomed, seat retainer ring by tapping with a hammer. Install adjustable flange and secure with hex nuts provided.

5. Carefully place reducer on its side. Rotate shaft to align keyseats in shaft and output hub and install key. Install shaft retainer, lockwasher, and bolt. Tighten bolts per Table 4.
6. Lay reducer on input shaft down and tighten adapter bolts per Table 4.

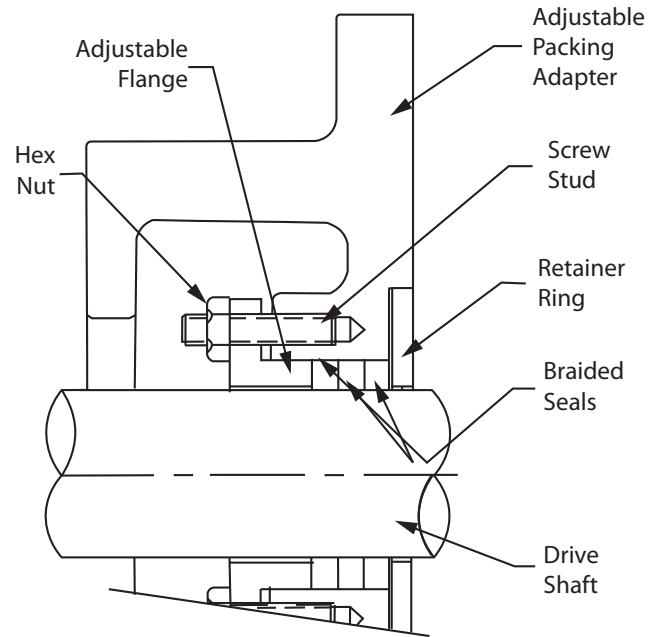

Figure 1 - Assembly

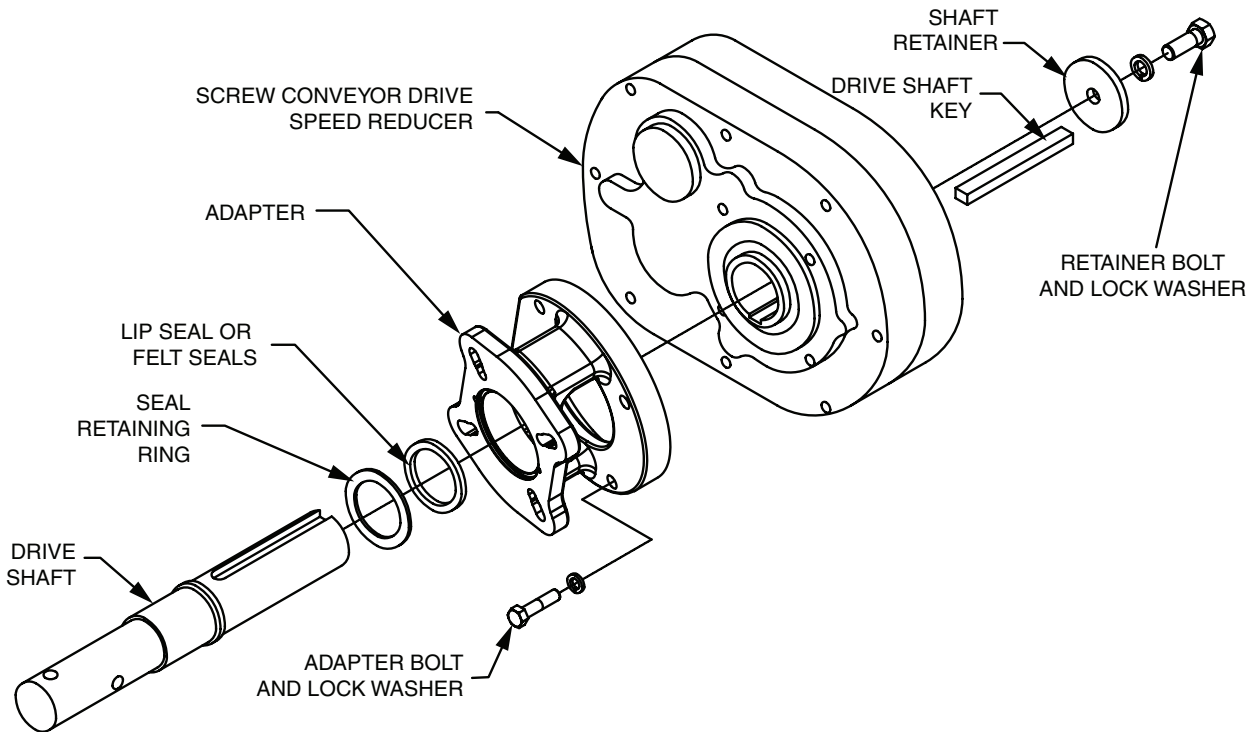

Figure 2- Optional Adjustable Packing Adapter

INSTALLATION

1. Determine the running positions of the reducer (Figure 3). Note that the reducer is supplied with 7 plugs; 5 around the sides for horizontal installations and 1 on each face for vertical installations. These plugs must be arranged relative to the running positions as follows:

Horizontal Installations – Install the magnetic drain plug in the hole closest to the bottom of the reducer. Throw away the tape that covers the filter/ventilation plug in shipment and install plug in topmost hole. Of the 3 remaining plugs on the sides of the reducer, the lowest one is the minimum oil level plug.

Vertical Installations – Install the filter/ventilation plug in the hole provided in the top face of the reducer housing. Use the hole in the bottom face for the magnetic drain plug. Of the 5 remaining holes on the sides of the reducer, use a plug in the upper housing half for the minimum oil level plug.

WARNING: To ensure that drive is not unexpectedly started, turn off and lock out or tag power source before proceeding. Failure to observe these precautions could result in bodily injury.

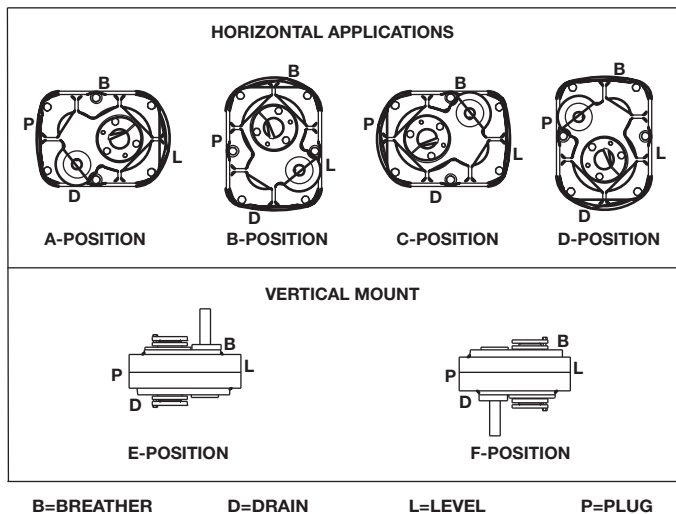

Figure 3 - Mounting Positions

NOTE: If motor mount, motor and sheaves are to be installed on reducer before mounting screw conveyor drive to trough end, bypass step 2; perform steps 3 and 4, and then return to step 2.

1. Use lifting tab to hoist screw conveyor drive into position. Slide shaft into screw and adapter over trough end studs. Only one set of adapter holes will fit over the trough end studs. If the mounted position of the screw conveyor varies more than 15° from any of the four horizontal mounting positions (Figure 1), an incorrect set of holes has been selected for coupling adapter to reducer. This can be corrected by removing adapter screws and rotating reducer to its proper position. Reinstall and tighten adapter screws to torque specified in Table 4. Install lockwashers and tighten nuts on trough end studs. Attach drive shaft to screw
2. Remove the three bolts from reducer housing required for mounting the SCD Motor Mount. Place the motor mount in position and install the three housing bolts supplied with the motor mount. Tighten bolts to torque specified in Table 4.

3. Install motor, drive sheave and driven sheave so that driven sheave is as close to the reducer housing as practical. Install V-belt and tension with the four adjusting screws provided on the SCD Motor Mount. Install belt guard. Make required electrical connections for motor.

WARNING: The user is responsible for conforming with the National Electrical Code and all other applicable local codes. Wiring practices, grounding, disconnects and overcurrent protection are of particular importance. Failure to observe these precautions could result in severe bodily injury or loss of life.

4. Because reducer is shipped without oil, it is necessary to add the proper amount before operating the drive. Use a high grade petroleum base, rust and oxidation inhibited (R & O) gear oil –see lubrication tables.

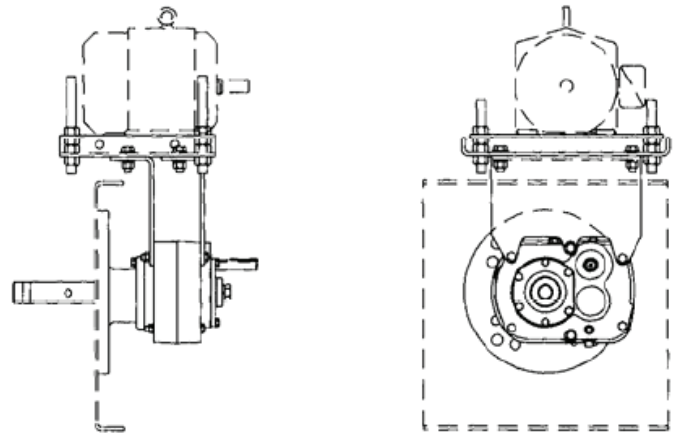

Figure 4 - Complete Drive

5. Retighten bolts and pipe plugs after a few days of operation. This prevents oil leakage.

CAUTION: Unit is shipped without oil. Add proper amount of recommended lubricant before operating. Failure to observe these precautions could result in damage to, or destruction of, the equipment.

LUBRICATION

Under average industrial operating conditions, the lubricant should be changed every 2500 hours of operation or every six months, whichever occurs first. Drain reducer and flush with kerosene, clean magnetic drain plug, and refill to proper level with new lubricant.

CAUTION: Too much oil will cause overheating and too little will result in gear failure. Check oil level regularly.

CAUTION: Extreme pressure (EP) lubricants are not recommended for average operating conditions. Failure to observe these precautions could result in damage to, or destruction of, the equipment.

Under extreme operating conditions, such as rapid rise and fall of temperatures, dust, dirt, chemical particles, chemical fumes, or oil sump temperatures above 200°F, the oil should be changed every 1 to 3 months, depending on the severity of the conditions.

Table 1 - Oil Volumes

Reducer Size	Volume of Oil Required to Fill Reducer to Oil Level Plug ①④																	
	② Position A			② Position B			② Position C			② Position D			② Position E			② Position F		
	Fluid Oz.	③ Qts.	Liters	Fluid Oz.	③ Qts.	Liters	Fluid Oz.	③ Qts.	Liters	Fluid Oz.	③ Qts.	Liters	Fluid Oz.	③ Qts.	Liters	Fluid Oz.	③ Qts.	Liters
(H)SCXT105	20	5/8	.59	24	3/4	.71	20	5/8	.59	24	3/4	.71	36	1	1.06	44	1	.30
(H)SCXT205	24	3/4	.71	28	7/8	.83	28	7/8	.83	28	7/8	.83	56	1-3/4	1.66	72	2-1/4	2.13
(H)SCXT305A	28	7/8	.83	48	1-1/2	1.42	44	1	1.30	44	1	1.30	80	2-1/2	2.37	100	3	2.96
(H)SCXT405A	48	1-1/2	1.42	72	2-1/4	2.13	68	2	2.01	60	1	1.78	128	4	3.79	156	4	4.61
(H)SCXT505A	108	3	3.19	136	4-1/4	4.02	124	3	3.67	120	3-3/4	3.56	248	7-3/4	7.33	288	9	8.52
SCXT605	144	4-1/2	4.30	184	5-3/4	5.40	144	4-1/2	4.30	160	5	4.70	384	12	11.40	352	11	10.4
SCXT705	240	7-1/2	7.10	288	9	8.50	240	7-1/2	7.10	296	9-1/4	8.80	608	19	18.0	552	17-1/4	16.30

① Below 15 RPM output speed, oil level must be adjusted to reach the highest oil level plug (P).

② Refer to Figure 3 for mounting positions.

Note: If reducer position is to vary from those shown in Figure 3, either more or less oil may be required. Consult Dodge product support.

③ U.S. Measure: 1 qt. = 32 fl. oz. = .94646 liters.

④ All liquid measure amounts are approximate.

Table 2 – Lubrication Recommendations – ISO Grades for Ambient Temperatures of 15°F to 60°F①

Output RPM	Reducer Size						
	1	2	3	4	5	6	7
301-400	220	220	150	150	150	150	150
201-300	220	220	150	150	150	150	150
151-200	220	220	150	150	150	150	150
126-150	220	220	220	150	150	150	150
101-125	220	220	220	220	150	150	150
81-100	220	220	220	220	220	150	150
41-80	220	220	220	220	220	150	150
11-40	220	220	220	220	220	220	220
1-10	220	220	220	220	220	220	220

Table 3 – Lubrication Recommendations – ISO Grades for Ambient Temperatures of 50°F to 125°F①

Output RPM	Reducer Size						
	1	2	3	4	5	6	7
301-400	320	320	220	220	220	220	220
201-300	320	320	220	220	220	220	220
151-200	320	320	220	220	220	220	220
126-150	320	320	320	220	220	220	220
101-125	320	320	320	320	220	220	220
81-100	320	320	320	320	320	220	220
41-80	320	320	320	320	320	220	220
11-40	320	320	320	320	320	320	320
1-10	320	320	320	320	320	320	320

①Notes:

Below -23°F call application engineering.

20°F to -22°F use Mobil SHC 627.

Above 125°F use Mobil SHC 634.

NOTE: Pour point of lubricant selected should be at least 10°F lower than expected minimum ambient starting temperature. See last page of manual for lubricant viscosity classification equivalents. Special lubricants may be required for food and drug industry applications where contact with the product being manufactured may occur. Consult a lubrication manufacturer's representative for his recommendation.

CAUTION: Do not use oils containing slippery additives such as graphite or molybdenum disulphide in the reducer when backstop is used. These additives will destroy sprag action. Failure to observe these precautions could result in damage to, or destruction of, the equipment.

GUIDELINES FOR TORQUE-ARM REDUCER LONG-TERM STORAGE

During periods of long storage, or when waiting for delivery or installation of other equipment, special care should be taken to protect a gear reducer to have it ready to be in the best condition when placed into service.

By taking special precautions, problems such as seal leakage and reducer failure due to lack of lubrication, improper lubrication quantity, or contamination can be avoided. The following precautions will protect gear reducers during periods of extended storage:

Preparation:

1. Drain the oil from the unit. Add a vapor phase corrosion inhibiting oil (VCI-105 oil by Daubert Chemical Co.) in accordance with Table 4.
2. Seal the unit air tight. Replace the vent plug with a standard pipe plug and wire the vent to the unit.
3. Cover the shaft extension with a waxy rust preventative compound that will keep oxygen away from the bare metal. (Non-Rust X-110 by Daubert Chemical Co.)
4. The instruction manuals and lubrication tags are paper and must be kept dry. Either remove these documents and store them inside or cover the unit with a durable waterproof cover which can keep moisture away.
5. Protect the reducer from dust, moisture, and other contaminants by storing the unit in a dry area.
6. In damp environments, the reducer should be packed inside a moisture-proof container or an envelope of polyethelene containing a desiccant material. If the reducer is to be stored outdoors, cover the entire exterior with a rust preventative.

When Placing the Reducer Into Service:

1. Assemble the vent plug into the proper hole.
2. Clean the shaft extensions with petroleum solvents.
3. Fill the unit to the proper oil level using a recommended lubricant. VCI oil will not affect the new lubricant.
4. Follow the installation instructions provided in this manual.

Table 4 - Quantity of VIC #105 Oil

Case Size	Quarts or Liters
(H)SCXT105	.1
(H)SCXT205	.1
(H)SCXT305A	.1
(H)SCXT405A	.2
(H)SCXT505A	.3
(H)SCXT605	.4
(H)SCXT705	.5

VCI #105 & #10 are interchangeable.

VCI #105 is more readily available.

OIL VISCOSITY EQUIVALENCY CHART

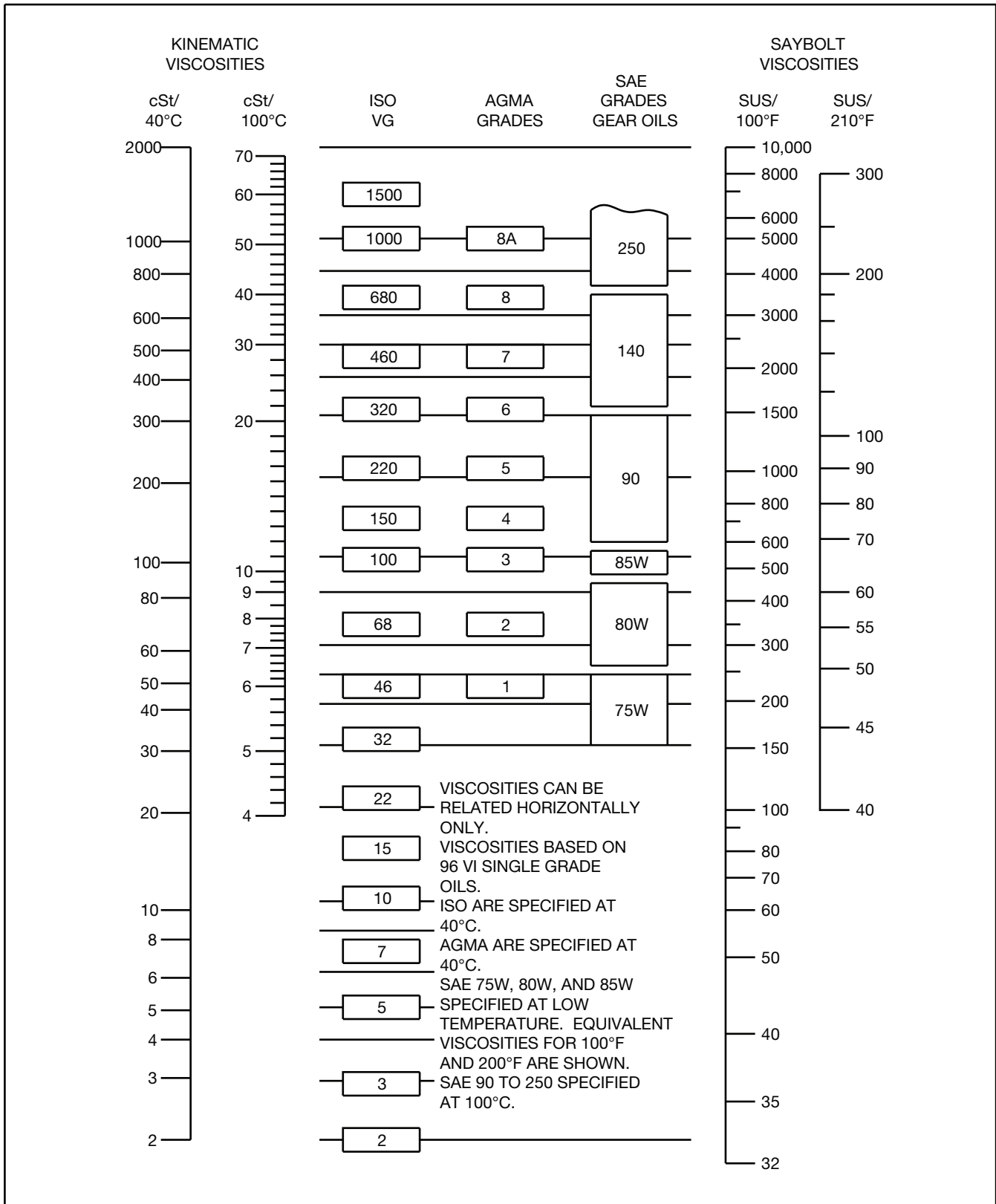

Figure 5 - Oil Viscosity Equivalency Chart

REPLACEMENT OF PARTS

Dodge is prepared to repair Screw Conveyor Drive speed reducers for customers who do not have the proper facilities or for those who desire factory service. However, if the customer has access to an arbor press, equipment for heating and shrinking bearings and gears on shafts, and the tools normally found in a maintenance department, the Screw Conveyor Drive speed reducer can easily be disassembled and reassembled by careful attention to the following instructions.

Cleanliness is very important to prevent the introduction of dirt into the bearings and other parts of the reducer. The oil seals are of the rubbing type and considerable care should be exercised during disassembly or reassembly to avoid damage to the surfaces on which these seals rub. Any sharp edges on the input shaft or output hub should be covered with adhesive tape or paper before performing any work on the unit. Nicks and burrs on surfaces or the input shaft or output hub should be removed.

ORDERING PARTS:

When ordering parts for reducer, specify Screw Conveyor Drive size and serial number, part name, part number, and quantity.

Parts that must be pressed from shafts or output hub should be removed before ordering parts. This assures that those parts, if damaged during pressing operation, will be replaced.

It is recommended that when a pinion or gear is replaced, the mating gear or pinion be replaced also. This insures that the gear teeth will mesh properly. If the large gear on the output hub must be replaced, it is suggested that an output hub assembly, consisting of a gear assembled on an output hub, be ordered to secure an output hub with undamaged surfaces on which the oil seals rub. However, if the old output hub is to be used, carefully press the gear and bearing cones off. Thoroughly examine the area under the oil seals for scratches or any other damage resulting from the pressing operation. To prevent leakage at the oil seals, the rubbing area must be smooth.

Replacements for the old oil seals should be ordered, due to the probability of these parts being damaged during disassembly. If replacing a bearing, output hub, or a shaft, it is advisable to order a set of shims for adjustment of bearings on the shaft assembly. If replacing a housing, a set of shims should be ordered for each shaft assembly because the adjustment of the bearings on each shaft assembly is affected.

REMOVING SCREW CONVEYOR DRIVE FROM THE TROUGH END:

Disconnect any electrical power to the drive. Drain lubricant from reducer. Uncouple drive shaft and screw. Remove nuts from trough end studs. Support drive by means of hoist and carefully pull unit away from trough end to slide drive shaft out of screw.

DISASSEMBLY:

1. Remove retainer bolt, lockwasher, and shaft retainer from drive shaft. Pull drive shaft out of reducer from adapter side. Remove adapter.
2. Position reducer on its side and remove all bolts. Gently tap the output hub and input shaft with a soft hammer (rawhide, not lead hammer) to separate the housing halves. Open housing evenly to prevent damage to the parts inside.
3. Lift shaft, gear and bearing assemblies from housing.
4. Remove seals, seal carriers, and bearing cups from housing.
5. Clean all parts in solvent, inspect for damage, and coat with oil.

REASSEMBLY:

1. Output Hub Assembly: Heat gear to 325°F to 350°F to shrink onto hub. Heat bearings to 270°F to 290°F to shrink onto hub. Any injury to the hub surfaces where the oil seals rub will cause leakage, making it necessary to use a new hub.
2. Input Shaft Assembly: Shaft and pinion are integral. Press bearings on shaft. Press against inner (not outer) race of bearings.
3. Drive the two dowel pins into place in the right hand housing half. Apply RTV732 sealant to carriers for R.H. side (backstop side) of reducer. Install carriers and torque bolts per Table 5.
4. Place R.H. housing half on blocks to allow for protruding end of output hub.
5. Install bearing cups in right-hand housing half, making sure they are properly seated.
6. Mesh output hub gear and input pinion assembly together and set in place in housing. Set input shaft assembly in place in the housing. Make sure bearing rollers (cones) are properly seated in their cups. Set bearing cups for left-hand housing half in place on their rollers.
7. Clean housing flange surfaces on both halves, making sure not to nick or scratch flange face. Place a 1/8" bead of RTV732 sealant on flange face (make sure RTV is placed between bolt holes and inside of flange face). Place other housing half into position and tap with a soft hammer (rawhide, not lead hammer) until housing bolts can be used to draw housing halves together. Torque housing bolts per torque values listed in Table 5.
8. Place output hub seal carrier in position without shims and install two carrier screws diametrically opposed. Torque each screw to 25 in. – lbs. Rotate the output hub to roll in the bearings and then torque each screw to 50 in. – lbs. Again turn output hub to roll in the bearings. With a feeler or taper gage, measure the gap between the housing and the carrier flange. To determine the required shim thickness, take the average of the two feeler gage readings. Remove carrier and install the required shims plus .002. Install carrier with shims and torque bolts per Table 5. Rotate hub assembly, tap lightly with rawhide mallet on end of hub, while rotating, to ensure bearings are seated. Using a dial indicator check end play of hub bearings, endplay should be .001–.003. Repeat this process as necessary to obtain proper end play. Place a 1/8" diameter bead of RTV732 sealant inside the carrier at the shim I.D. and install carrier on reducer housing. Torque carrier bolts to value shown in Table 5.
9. Using the same procedure as in step 8, adjust the input shaft bearings, except the axial end play should be .002" to .004".
10. Using gaskets or RTV732, install input shaft cover to right-hand housing half. Install input and output seals. Extreme care should be used when installing seals to avoid damage due to contact with sharp edges on the input shaft or output hub. The possibility of damage and consequent oil leakage can be decreased by covering all sharp edges with tape prior to seal installation. Fill cavity between seal lips with grease. Seals should be pressed or tapped with a soft hammer evenly into place in the carrier, applying pressure only on the outer edge of the seals. A slight oil leakage at the seals may be evident during initial running, but should disappear unless seals have been damaged.

Table 5 - Recommended Torque Values

Torque-Arm Reducer Drive Size	Recommended Torque (ft.-lbs.)						
	Adapter Bolts	Housing Bolts	OP Hub Seal Carrier Bolts	Countershaft Bearing Carrier Bolts	RH Countershaft Bearing Cover Screws	Hydroil Motor Adapter Screws	Backstop Cover Bolts
(H)SCXT105	27-30	27-30	n/a	n/a	n/a	8	n/a
(H)SCXT205	45-50	27-30	n/a	n/a	n/a	8	n/a
(H)SCXT305A	68-75	45-50	15-17	15-17	15-17	15-17	15-17
(H)SCXT405A	135-150	45-50	27-30	27-30	n/a	27-30	27-30
(H)SCXT505A	135-150	68-75	27-30	27-30	27-30	27-30	27-30
(H)SCXT605	135-150	68-75	27-30	27-30	27-30	27-30	27-30
(H)SCXT705	135-150	135-150	45-50	45-50	45-50	45-50	45-50

Note: Tighten sufficient to prevent oil leaks.

Table 6 - Part Numbers for Replacement Bearings

Torque-Arm Reducer Drive Size	Output Hub Bearing	Countershaft Bearing Input Side	Countershaft Bearing Output Side	Input Bearings Input Side	Input Bearings Output Side
	Part No.	Part No.	Part No.	Part No.	Part No.
105	402246 403149	n/a	n/a	424076	424012
205	402247 403150	n/a	n/a	424078	424000
305A	402272 403127	n/a	n/a	402190 403132	402271 403101
405A	402268 403163	n/a	n/a	402179 403006	402285 403125
505A	402193 403016	n/a	n/a	402270 403026	402266 403073
605	402050 403140	n/a	n/a	402053 403106	402123 403009
705	402058 403111	n/a	n/a	402057 403143	402078 403034

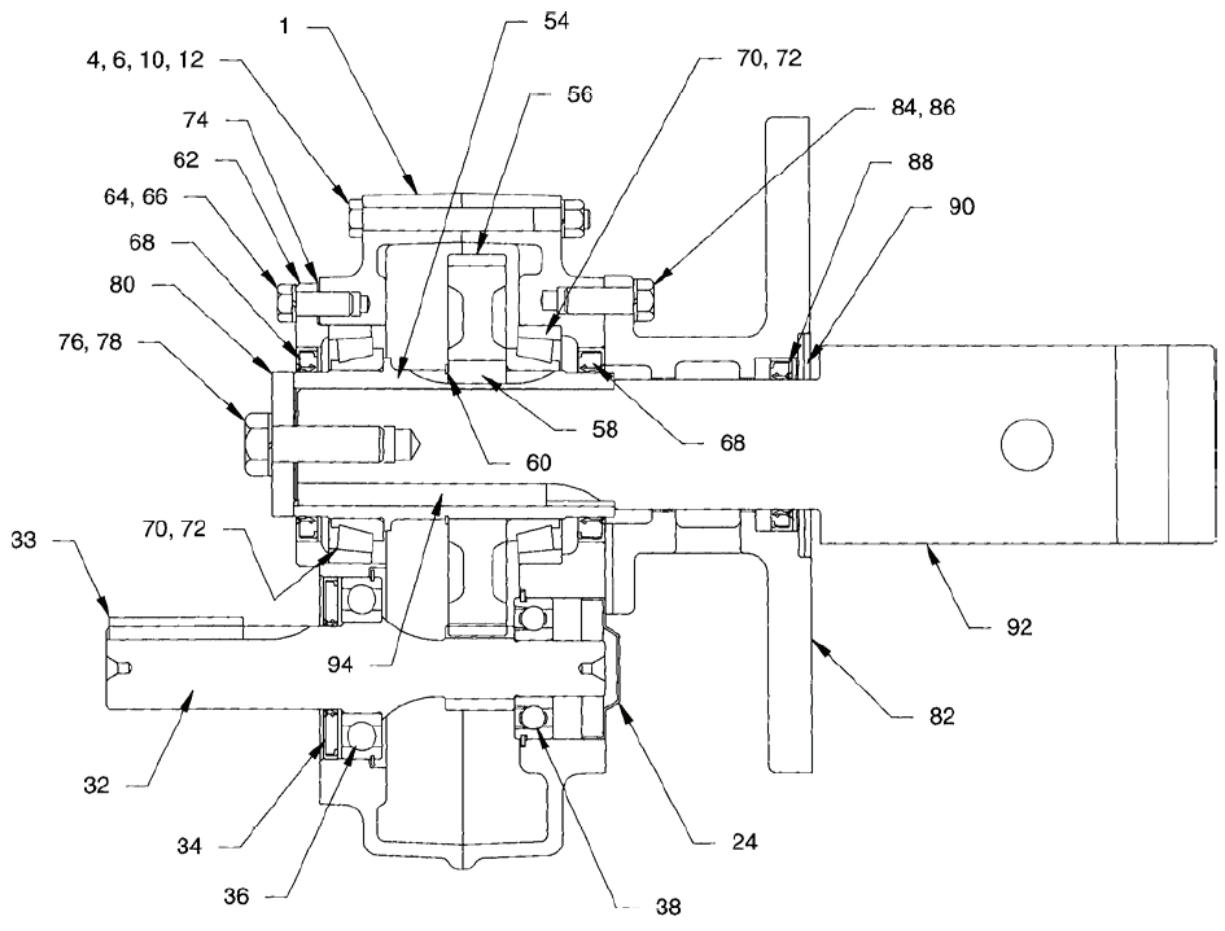

**Figure 6 - Parts for SCXT105, SCXT205, HSCXT105 & HSCXT205
Screw Conveyor and Hydroil Screw Conveyor Drive**

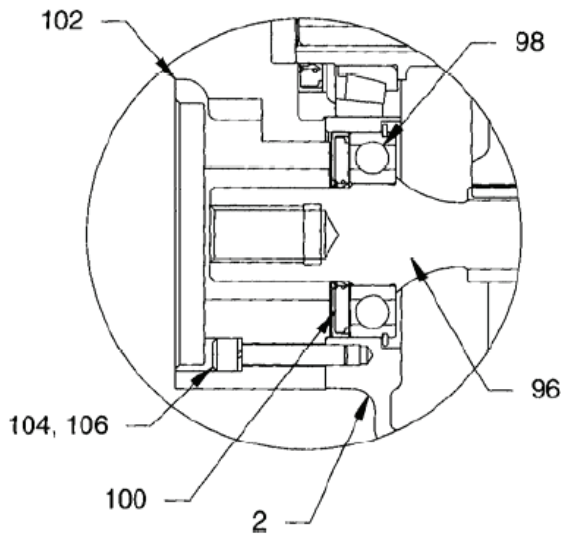

NOTE: Parts for HSCXT Screw Conveyor Drives are the same as for SCXT Screw Conveyor Drives, except as noted in this view.

Figure 7 - HSCXT105 and HSCXT205

Table 7 - Parts for SCXT105, SCXT205, HSCXT105 & HSCXT205 Screw Conveyor and Hydroil Screw Conveyor Drive

Reference	Name of Part	Number Required	(H)SCXT105	(H)SCXT205
1	SCXT Housing	1	351235	352179
2	HSCXT Housing	1	351241	352246
③	Air Vent	1	900287	900287
4	Housing Bolt	④	411418	411418
6	Lockwasher	⑦	419011	419011
③	Washer	4	419092	419092
10	Hex Nut	④	407087	407087
12	Dowel Pin	2	420091	420091
③	Pipe Plug	5	430031	430031
③	Magnetic Drain Plug	1	430060	430060
③	Smart Sensor Adapter	1	966905	966905
24	Input Shaft Bearing Cover	1	361062	354112
32 ⑥	Input Shaft with Pinion	5:1 Ratio	251020	242214
33	Input Shaft Key	1	443013	443052
36 ⑥	Input Shaft Bearing (Input Side)	1	424076	424078
38 ⑥	Input Shaft Bearing (Output Side)	1	424012	424000
	Output Hub Assembly ①	1	391029 HA	392105 HA
54 ⑥	② Output Hub	1	351112	352112
56 ⑥	② Output Hub Gear	1	241007	242181
58 ⑥	② Output Hub Gear Key	1	241217	443399
70 ⑥	Output Hub Bearing Cone	2	402246	402247
62	Output Hub Seal Carrier	1	351114	362051
64	Carrier Screw	6	411405	032018008CJ
66	Lockwasher	6	419010	419011
72 ⑥	Output Hub Bearing Cup	2	403149	403150
74	Output Hub Shim Pack	1 Set	391056	392160
76	Retainer Bolt	1	411549	411549
78	Lockwasher	1	034017018AB	034017018AB
80	Shaft Retainer	1	351116	352116
①	Adapter Assembly	1	351086	352052
82 ②	⑧ Adapter	1	356169	356113
84 ②	Bolt	4	032018010CJ	411433
86 ②	Lockwasher	4	419011	419012
88 ②	Lip Seal	1	351123	901286
90 ②	Seal Retaining Ring	1	351121	352121
①⑨	Adjustable Packing Kit	1	356301	356302
②③	Adjustable Packing Retainer	1	356134	356115
②③	Stud	2	400404	400404
②③	Hex Nut	2	407202	407200
②③	Braided Seal	3	427663	427659

Table 7 - Parts for SCXT105, SCXT205, HSCXT105 & HSCXT205 Screw Conveyor and Hydroil Screw Conveyor Drive

Reference	Name of Part	Number Required	(H)SCXT105	(H)SCXT205	
92	Drive Shaft ①	1-1/2" Dia.	1	351094	352090
		2" Dia.	1	351095	352091
		2-7/16" Dia.	1	351096	352092
		3" Dia.	1	351097	352093
		3-7/16" Dia.	1	—	—
94	② Key	1	443287	443223	
①	SCXT Seal Kit	1	272716	272717	
34 ②	⑥ Input Shaft Seal	1	242211	244211	
68 ②	⑥ Output Hub Seal	2	351113	352113	
①	HXCXT Seal Kit	1	236115	272717	
100 ②	⑥ Input Seal	1	251089	244211	
68 ②	⑥ Output Hub Seal	2	351113	352113	
③ ⑥	RTV Sealant, Tube	1	415112-80-H	415112-80-H	
96 ⑥	Hydroil Input Pinion 5:1 Ratio	1	251086	242215	
98 ⑥	Input Shaft Bearing (Input Side)	1	424137	424078	
100 ⑥	Input Seal	1	251089	252063	
102	Hydroil Motor Adapter	1	361076	362077	
104	Adapter Screw	5	417090	417090	
106	Lockwasher	5	419046	419046	

- ① Includes parts listed immediately below marked "②".
- ② Makes up assembly under which listed.
- ③ Not shown on drawing.
- ④ 6 required for (H)SCXT105; 7 for (H)SCXT205.
- ⑤ Used only on (H)SCXT105 and (H)SCXT205 with 1-1/2" diameter shafts.
- ⑥ Recommended spare parts.
- ⑦ 4 required for (H)SCXT105; 5 required for (H)SCXT205.
- ⑧ Must buy complete adapter assembly.
- ⑨ Must have adapter assembly to use packing kit.

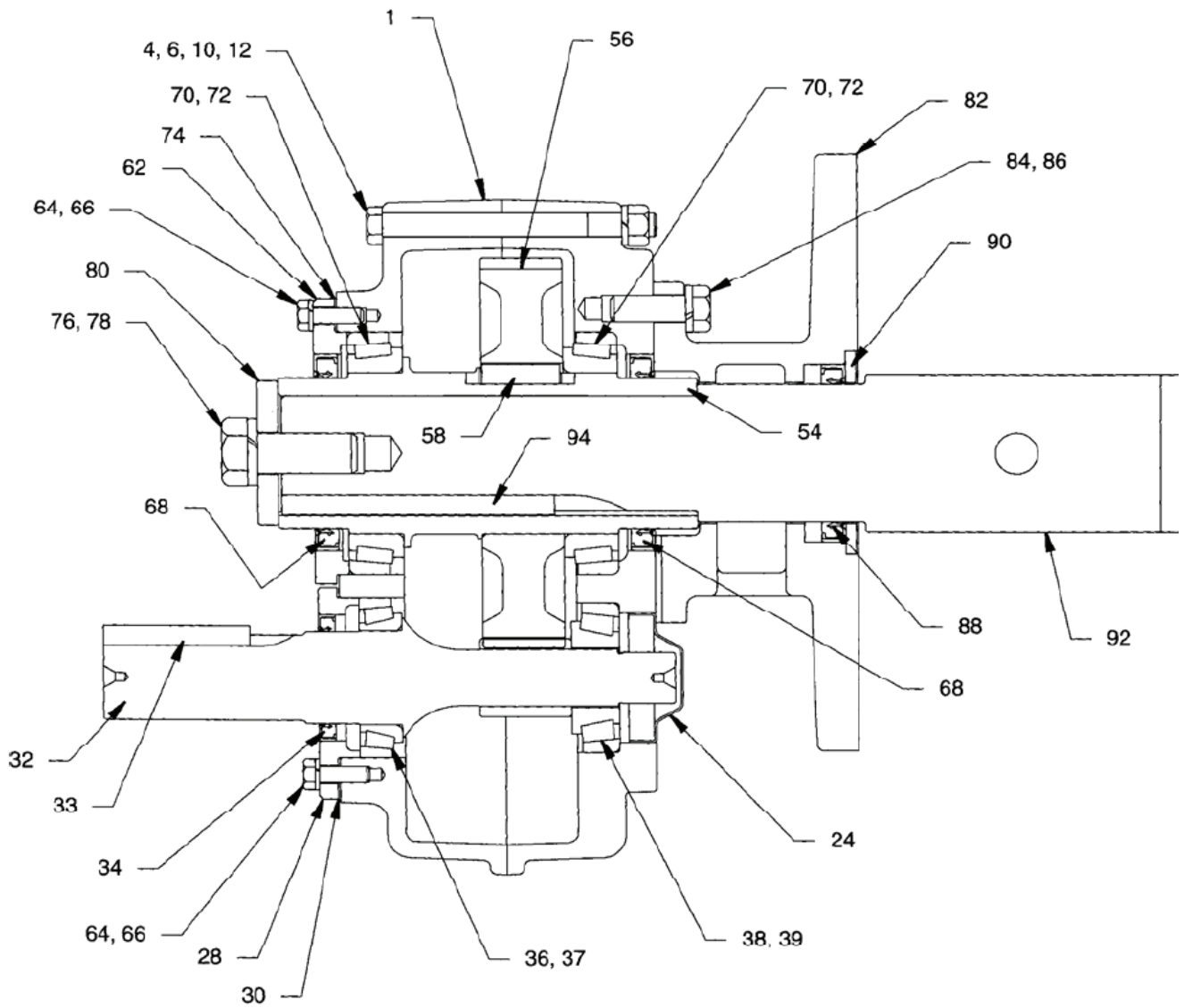

**Figure 8 - Parts for SCXT305A, SCXT405A, SCXT505A & HSCXT305A, HSCXT405A & HSCXT505A
Screw Conveyor and Hydroil Screw Conveyor Drive**

NOTE: Parts for HSCXT Screw Conveyor Drives are the same as for SCXT Screw Conveyor Drives, except as noted in this view.

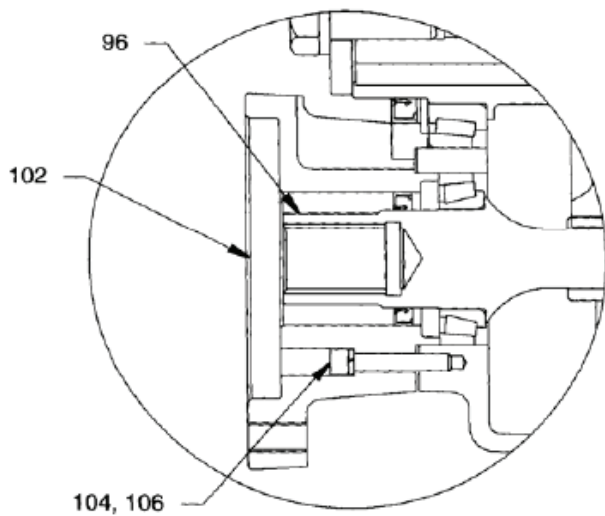

Figure 9 - HSCXT305A, HSCXT405A and HSCXT505A

**Table 8 - Parts for SCXT305A, SCXT405A, SCXT505A & HSCXT305A, HSCXT405A & HSCXT505A
Screw Conveyor and Hydroil Screw Conveyor Drive**

Reference	Name of Part	Number Required	(H)SCXT305A	(H)SCXT405A	(H)SCXT505A	
1	(H)SCXT Housing	1	253169	254220	255220	
③	Air Vent	1	900287	900287	904287	
4	Housing Bolt	8	411440	411442	411464	
6	Lockwasher	8	419012	419012	419013	
③	Washer	4	419094	419094	419096	
10	Hex Nut	8	407089	407089	407091	
12 ⑨	Dowel Pin	2	420055	420055	420110	
③	Pipe Plug	2	430031	430031	430033	
③	Smart Sensor Adapter	1	966905	966905	966906	
③	Magnetic Drain Plug	1	430060	430060	430062	
24	Input Shaft Bearing Cover	1	253149	254275	245624	
28	Input Shaft Seal Carrier	1	253177	254224	255224	
30 ⑥	Input Shaft Bearing Shim Pack	2 Sets	389723	389724	389725	
32 ⑥	Input Shaft with Pinion	5:1 Ratio	1	253170	254230	255221
33	Input Shaft Key	1	443078	443096	443113	
36 ⑥	Input Shaft Bearing Cone (Input Side)	1	402190	402179	402270	
37 ⑥	Input Shaft Bearing Cup (Input Side)	1	403132	403006	403026	
38 ⑥	Input Shaft Bearing Cone (Output Side)	1	402271	402285	402266	
39 ⑥	Input Shaft Bearing Cup (Output Side)	1	403101	403125	403073	
	Output Hub Assembly ①	1	389702	389709	389716	
54 ⑥	② Output Hub	1	243557	244589	245591	
56 ⑥	② Output Hub Gear	1	243570	244188	245186	
58 ⑥	② Output Hub Gear Key	2	243216	391015	391026	
62	Output Hub Seal Carrier	1	243547	244591	255236	
64	Carrier Screw	10 ⑨	411390	032018008CJ	032018008CJ	
66	Lockwasher	10 ⑨	419010	419011	419011	
70 ⑥	Output Hub Bearing Cone	2	402272	402268	402193	
72 ⑥	Output Hub Bearing Cup	2	403127	403163	403016	
74	Output Hub Shim Pack	1 Set	243139	244153	245139	
76	Retainer Bolt	1	411551	411551	411551	
78	Lockwasher	1	034017020AB	034017020AB	034017020AB	
80	Shaft Retainer	1	353053	354088	355065	
	Adapter Assembly ①	1	353047	354121	355072	
82 ⑦	② Adapter	1	356164	356150	356159	
84	② Bolt	4	411456	411483	411483	
86	② Lockwasher	4	419013	034017018AB	034017018AB	
88	② Lip Seal	1	353085	354115	355067	
90	② Seal Retaining Ring	1	353054	354089	355066	
①	Adjustable Packing Kit ⑧	1	356303	356304	356305	
③	Adjustable Packing Retainer ②	1	356166	356152	356161	
③	Stud ②	2	400404	400404	400404	
③	Hex Nut ②	2	407202	407202	407202	
③	Braided Seal ②	3	427658	427664	427674	
92	Drive Shaft ①	1-1/2" Dia.	1	243562	244594	—
		2" Dia.	1	243563	244595	355175
		2-7/16" Dia.	1	243564	244596	355176
		3" Dia.	1	243565	244597	355177
		3-7/16" Dia.	1	—	244598	355178
94	② Key	1	443098	443114	443239	
	Seal Kit ⑥ ①	1	389726	389727	389728	
34	② Input Seal	1	351123	334277	245546	
68	② Output Seal	2	902286	A73109	404286	
③	RTV Sealant, Tube	1	415112-80-H	415112-80-H	415112-80-H	
96 ⑥	Hydroil Input Pinion	5:1 Ratio	1	253171	254231	255222
102	Hydroil Motor Adapter	1	253172	254222	255226	
104	Adapter Screw	6 ⑤	417090	417120	417120	
106	Lockwasher	6 ⑤	419046	419047	419047	

- ① Includes parts listed immediately below marked ②.
- ② Makes up assembly under which listed.
- ③ Not shown on drawing.
- ④ 12 required for SCXT505A; 6 for HSCXT305A, HSCXT405 and HSCXT505A.
- ⑤ 4 required for HSCXT305A.
- ⑥ Recommended spare parts.
- ⑦ Must buy complete Adapter Assembly.
- ⑧ Must have adapter assembly to use packing kit.
- ⑨ Included with housing assembly.

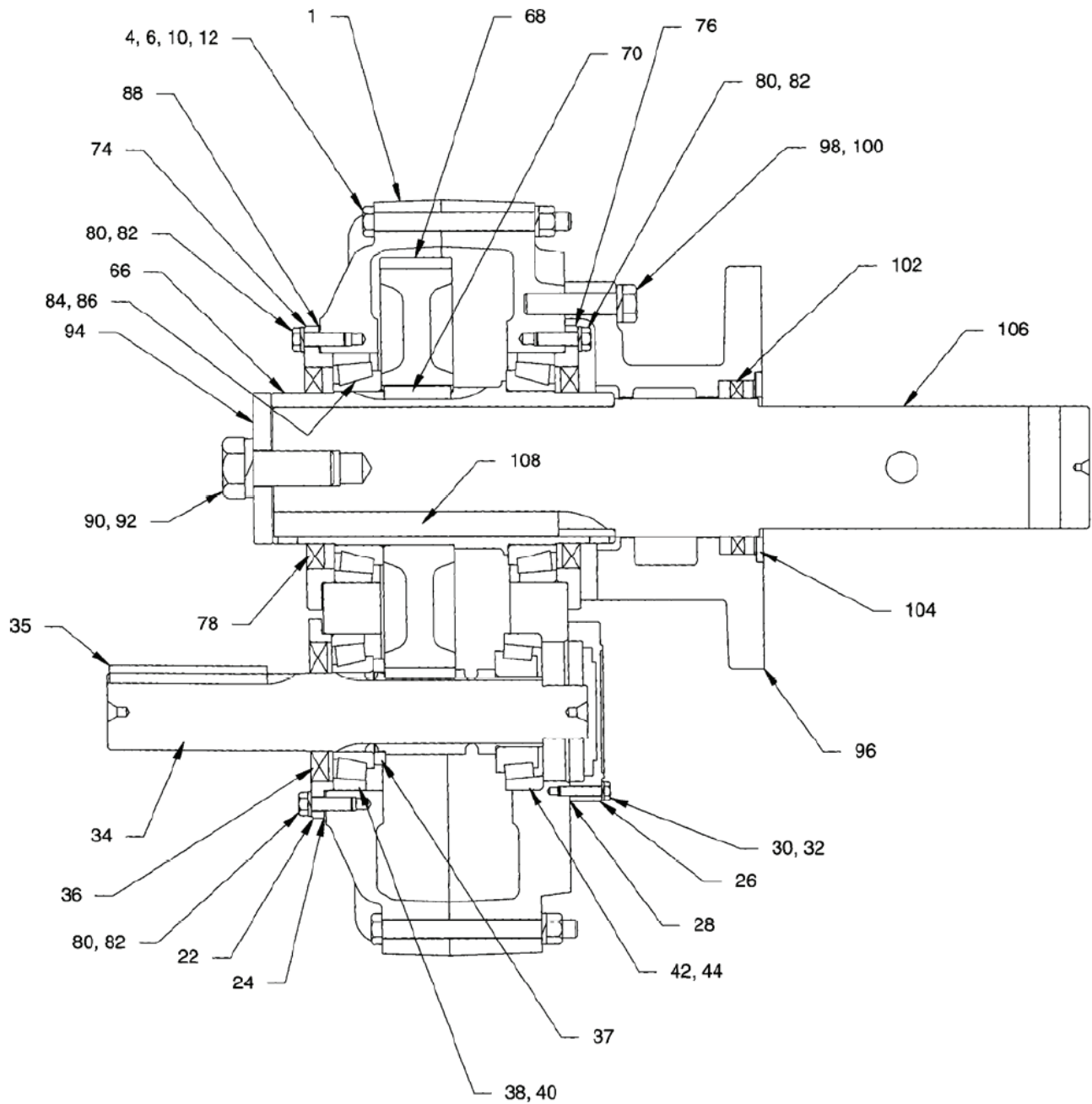

Figure 10 - Parts for SCXT605 - SCXT705 Screw Conveyor Drive

Table 9 - Parts for SCXT605 - SCXT705 Screw Conveyor Drive					
Reference	Name of Part	Number Required	SCXT605	SCXT705	
1	SCXT Housing Assembly	1	246174	247184	
③	Air Vent	1	904287	390061	
4	Housing Bolt	8	411466	411498	
6	Lockwasher	8	419013	034017020AB	
③	Washer	2	419096	419082	
10	Hex Nut	8	407091	407095	
12 ⑥	Dowel Pin	2	420112	420128	
③	Pipe Plug	4	430033	430035	
③	Smart Sensor Adapter	1	966906	966907	
③	Magnetic Drain Plug	1	430062	430064	
22	Input Shaft Seal Carrier	1	246184	257045	
24 88	Complete Shim Kit ⑤	1	246166	247138	
26	Input Shaft Bearing Cover	1	246221	247221	
30	Input Shaft Cover Screw	6	411404	411402	
32	Lockwasher	6	419009	419009	
34 ⑤	Input Shaft with Pinion	5:1 Ratio	1	256028	257044
35	Input Shaft Key	1	443113	443127	
37 ⑤	Input Shaft Bearing Spacer	1	256030	—	
38 ⑤	Input Shaft Bearing Cone (Input Side)	1	402053	402057	
40 ⑤	Input Shaft Bearing Cup (Input Side)	1	403106	403143	
42 ⑤	Input Shaft Bearing Cone (Output Side)	1	402123	402078	
44 ⑤	Input Shaft Bearing Cup (Output Side)	1	403009	403034	
	Output Hub Assembly ①	1	390988	390990	
66 ⑤	② Output Hub	1	246338	247338	
68 ⑤	② Output Hub Gear	1	246295	247215	
70 ⑤	② Output Hub Gear Key	2	245217	245217	
74	Output Hub Seal Carrier (Input Side)	1	246187	247315	
76	Output Hub Seal Carrier (Output Side)	1	246186	247315	
80	Carrier Screw	④	032018010CJ	411433	
82	Lockwasher	④	419011	419012	
84 ⑤	Output Hub Bearing Cone	2	402050	402058	
86 ⑤	Output Hub Bearing Cup	2	403140	403111	
24 88	Complete Shim Kit ⑤	1	246166	247138	
90	Retainer Bolt	1	411552	411552	
92	Lockwasher	1	419020	419020	
94	Shaft Retainer	1	356047	356191	
	Adapter Assembly ①	1	356055	356187	
96	② ⑥ Adapter	1	356155	356193	
98	② Bolt	4	032018020EJ	411496	
100	② Lockwasher	4	034017018AB	034017020AB	
102	② Lip Seal	1	355054	355054	
104	② Seal Retaining Ring	1	356054	356054	
108	② Key	1	443288	443289	
	Adjustable Packing Kit ① ⑦	1	356306	356306	
③	② Adjustable Packing Retainer	1	356157	356157	
③	② Stud	2	400404	400404	
③	② Hex Nut	2	407202	407202	

Table 9 - Parts for SCXT605 - SCXT705 Screw Conveyor Drive					
Reference	Name of Part	Number Required	SCXT605	SCXT705	
③	② Braided Seal	3	427687	427687	
106	Drive Shaft ①	1-1/2" Dia.	1	356040	356180
		2" Dia.	1	356041	356181
		2-7/16" Dia.	1	356042	356182
		3" Dia.	1	356043	356183
		3-7/16" Dia.	1	356044	356184
108	② Key	1	443288	443289	
	Seal Kit ⑤①	1	272705	247345	
28⑤	② Input Shaft Cover Gasket	1	246220	246220	
36⑤	② Input Shaft Seal	1	256032	242113	
78⑤	② Output Hub Seal	2	905286	247310	
③	RTV Sealant, Tube	1	415112-80-H	415112-80-H	

- ① Includes parts listed immediately below marked ②.
- ② Makes up assembly under which listed.
- ③ Not shown on drawing.
- ④ 18 required for SCXT605; 22 for SCXT705.
- ⑤ Recommended spare parts.
- ⑥ Must buy complete Adapter Assembly.
- ⑦ Must have adapter assembly to use packing kit.
- ⑧ Included with housing assembly.

Dodge Industrial, Inc.
1061 Holland Road
Simpsonville, SC 29681
+1 864 297 4800



* 1 6 3 8 - 0 2 2 2 *