



Installation & Maintenance Instructions for Dodge Maxum XTR Speed Reducers Sizes 50-130

These instructions must be read thoroughly before installation or operation. This instruction manual was accurate at the time of printing. Please see dodgeindustrial.com for updated instruction manuals.

WARNING: To ensure the drive is not unexpectedly started, turn off and lock-out or tag power source before proceeding. Failure to observe these precautions could result in bodily injury.

WARNING: All products over 25 kg (55 lbs) are noted on the shipping package. Proper lifting practices are required for these products.

CAUTION: The reducer must be mounted on a flat base with proper shimming. Failure to observe this precaution could result in damage to or destruction of the equipment.

CAUTION: Equipment is very heavy. Use proper lifting equipment rated for the load to be moved or lifted. For lifting drive base, motor, and reducer assembly, refer to assembly documentation for correct weight. Use lifting holes provided on the drive base for lifting. Figure 1 shows typical lifting locations. To move or lift a MAXUM XTR reducer above, use the four lifting brackets provided on the upper portion of the reducer housing. Do not use these brackets to lift an entire reducer, motor and drive base assembly.

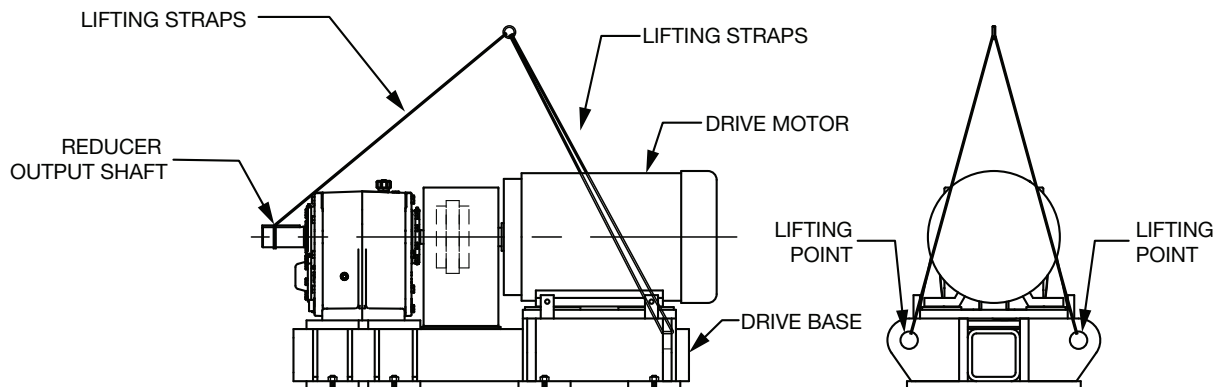

Figure 1 - Typical Lifting Points

WARNING: Because of the possible danger to person(s) or property from accidents which may result from the improper use of products, it is important that correct procedures be followed. Products must be used in accordance with the engineering information specified in the catalog. Proper installation, maintenance and operation procedures must be observed. The instructions in the instruction manuals must be followed. Inspections should be made as necessary to assure safe operation under prevailing conditions. Proper guards and other suitable safety devices or procedures as may be desirable or as may be specified in safety codes should be provided, and are neither provided by Dodge nor are the responsibility of Dodge. This unit and its associated equipment must be installed, adjusted and maintained by qualified personnel who are familiar with the construction and operation of all equipment in the system and the potential hazards involved. When risk to persons or property may be involved, a holding device must be an integral part of the driven equipment beyond the speed reducer output shaft.

GENERAL INFORMATION

The Dodge MAXUM Gear reducer is designed in accordance with the standards of the American Gear Manufacturers Association to give years of trouble-free operation. Unauthorized modifications are not allowed. In order to obtain good performance, there are precautions and procedures that must be observed when installing and servicing the reducer. This instruction manual contains installation, operating, and maintenance information for your reducer and its accessories. Additional information can be obtained by contacting your local Dodge sales office, distributor or authorized service center.

INSTALLATION:

NOTE: This his reducer is compatible with the Dodge Smart Sensor, that can be installed in the adapter plug labelled "smart sensor". The plug and sensor can be moved to different locations as required by mounting position.

Initial Receiving Inspection

Carefully inspect the drive units for obvious outside damage. If any form of damage is present, notify the carrier and take photos for future use. Great care was taken to insure that the cargo was very well protected. Accessories such as heat exchangers, guards, and couplings may be packaged separately

Foundation

1. A foundation for mounting the reducer must be of sufficient size and rigidity to prevent movement when the MAXUM unit is installed and operated, and to maintain the alignment between the driven equipment, the MAXUM, and the drive motor. The foundation surface must be flat and level to within 1/16" (1.5 mm) to prevent distortion of the base plate or reducer when hold down bolts are tightened. A well laid concrete slab is the most effective way of ensuring a sound foundation. Steel sub bases can be used under the drive base.

 - An elevated foundation will make oil drainage easier.
 - The foundation must also have adequate strength and rigidity to withstand the operating forces resulting from the starting torque of the motor multiplied by the gear reduction ratio. Starting motor torque values can be three to even four times higher than nominal motor torque ratings.
 - When the geardrive is directly attached to another component (i.e., an outboard bearing on the end of the reducer output shaft), one supporting structure shall be used to mount both components.
 - Drive bases must be thermally stress relieved after fabrication for long term dimensional stability. It is preferred to have both the top and bottom surfaces machined flat to facilitate shimming. However, it is acceptable to have only the top mounting surfaces machined.

Steel Foundations

When mounting a reducer on structural steel, an engineered rigid baseplate is recommended. Fabricated pedestals or baseplates must be carefully designed to assure that they are sufficiently rigid to withstand operating conditions. DODGE MAXUM motor baseplates are fabricated from heavy steel to achieve the necessary rigidity. Bolt the reducer and baseplate securely to the steel supports with proper shimming to ensure a flat and level surface.

Concrete Foundations

If the reducer is to be mounted on a concrete foundation, grout steel mounting pads into the concrete base rather than grouting the reducer directly onto the concrete.

If the reducer is mounted on a baseplate which will be installed on a concrete foundation, use the following instructions:

- The top of the foundation slab or steel sub base should be left 1" to 1.5" (25 to 38 mm) lower than will finally be required to allow for grouting. When installing, the foundation should be roughened, cleaned, and dampened before placing the drive base in position. When installing the drive base on a steel sub base use epoxy type grout. When installing the drive base on a concrete foundation either epoxy type grout or non-shrinking Portland cement type of grout can be used.
- Foundation bolts should be secured in the concrete as shown in Figure 2. Allow adequate length for the bolts. Foundation bolts can be placed in the concrete at the time the concrete is poured.

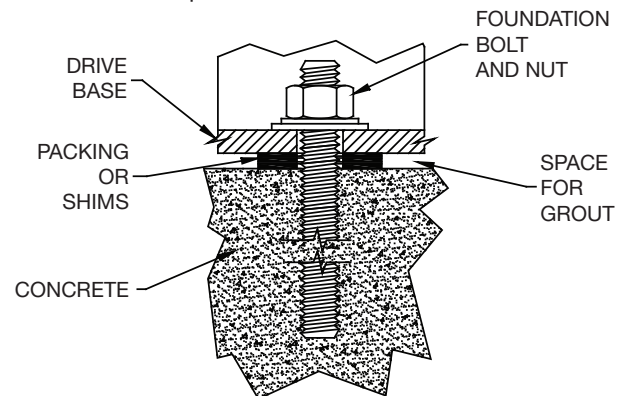

Figure 2 - Foundation Bolts Secured in Concrete

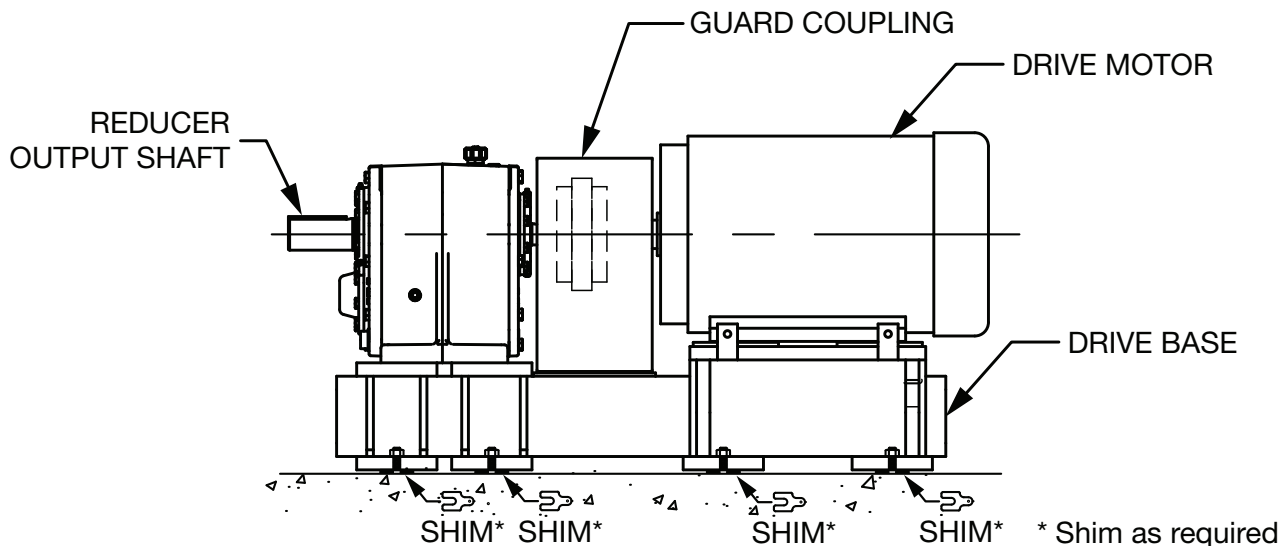

Figure 3 - Typical Base Mounting

- Packing shims are placed between the top of the foundation and the baseplate until the unit is 1" to 1.5" (25 to 38 mm) clear of the foundation. Adjust the packing or shims until a level placed on the baseplate indicates the base is level. See Figure 3 for typical base mounting.
- After a preliminary alignment between the MAXUM input and output couplings, the space between the top of the concrete surface and the bottom of the drive baseplate must be filled with grout. The grout should be thoroughly worked under the baseplate and be allowed to completely set (at least 72 hours). After the grout has set, the holding bolts should be tightened evenly. Final alignment of the MAXUM should be checked after the grout has set and the hold down bolts have been tightened.

Coupling Hub Installation

Follow the installation instructions provided by the coupling manufacturer. Some general guidelines are provided that will aid in coupling installation. If the reducer is supplied with a backstop, do not connect couplings until the motor shaft direction of rotation is verified and is correct for the freewheeling rotation of the geardrive.

- Accurately measure the hub bore and shaft diameter to verify that each coupling hub and its shaft have an interference fit and that the amount of interference is adequate.
- Check the dimensions of the key on the shaft and on the coupling bore. Make sure the key is going to fit in the shaft and coupling keyways.
- Check the fit of the key in both the hub and shaft. The key should fit snugly against the sides of the keyway. A slight clearance should be present from top to bottom when the hub is on the shaft. Insert key flush with the end of the shaft.
- Check shaft, hub bore, and keys for nicks and burrs and remove as necessary.
- Use an oil bath to heat the coupling hubs to 245°F (118°C). Remove flexible elements before heating. Any kind of oil such as gear oil can be used as long as the flash temperature of the oil is high enough to avoid a fire hazard. Check the temperature of the coupling hub frequently with a Tempilstick to avoid overheating.
- Alternatively mark the hub with a 275°F (135°C) temperature sensitive crayon (melts at prescribed temperatures) in several places on the hub. Remove flexible elements before heating. Use an oxy-acetylene or a blow torch to heat the hub. When using an oxy-acetylene torch use an excess acetylene mixture. Direct the flame toward the hub bore and keep it in motion while heating. Avoid overheating an area.

WARNING: Use of an open flame in a combustible atmosphere or near combustible materials may result in bodily injury and damage to equipment.

- Mount the hub on the shaft as quickly as possible to avoid heat loss. Carefully line up bore and keyway with shaft and keyway and slide hub onto shaft until the shaft is at the right location relative to the shaft end. If it is necessary to drive hub into position, lightly tap with a soft brass or lead hammer. DO NOT USE excessive pounding which can cause damage to the bearings or gears.
- Allow coupling hub and shaft assembly to cool.

Sheaves and Sprockets

Mount sheaves and sprockets as close to the reducer as possible. Overtightening may cause damage to the reducer, belts or chain or driven equipment. Adjust chains to manufacturer's recommendations.

Alignment and Leveling

Align the output shaft to the driven equipment shaft. Start at the output end and work toward the input end when aligning. If shims are used to align the reducer or baseplate, they must be distributed uniformly to support the entire mounting surface. The supported load must be equalized to avoid any distortion or localized stress. It is preferred to shim under the reducer foot for height adjustment.

Use feeler gauges to determine the correct shim thickness needed to support each pad. All pads must be evenly supported when alignment is achieved and the foundation bolts are tightened. Use shims large enough to provide adequate support. If shims are not installed properly, they may get dislodged which will cause severe misalignment resulting in damage to all components in the system. When the output shaft alignment is complete, tighten the foundation fasteners to the torque values appropriate for the bolt size per Table 1. Recheck alignment after reducer foundation bolts are tightened.

If the reducer was received mounted on a baseplate, it is possible that misalignment was introduced at the input coupling during transit. Alignment must be checked and/or adjusted prior to operation. Remove guards and covers as necessary to access foundation bolts. Align the motor to the reducer input shaft using the process described above. Replace guards and covers after alignment has been achieved and tighten motor foundation bolts to the torque value appropriate for the bolt size per Table 1. Recheck alignment after motor foundation bolts are tightened.

Table 1 – Mounting Fastener Tightening Torques (coarse thread series)

Inch Fasteners		Metric Fasteners		
Nominal Diameter	Grade SAE 5 Tightening Torque	Nominal Diameter (mm)	Class 8.8 Tightening Torque	
inch	lb-ft	mm	lb-ft	Nm
0.312	13	M8	14	[18]
0.375	23	M10	27	[37]
0.500	57	M12	47	[64]
0.625	110	M16	120	[160]
0.750	200	M20	240	[310]
0.875	320	M24	420	[535]
1.000	480	M30	840	[1060]
1.125	600	M36	1450	[1850]
1.250	840	M48	3500	[4450]
1.500	1450			
1.750	3300			

CAUTION: The life of the reducer bearings is adversely affected by coupling misalignment.

Coupling Alignment

Refer to the coupling manufacturer for the maximum recommended parallel and angular misalignment limits. Align the shafts to meet the coupling manufacturer's recommendations.

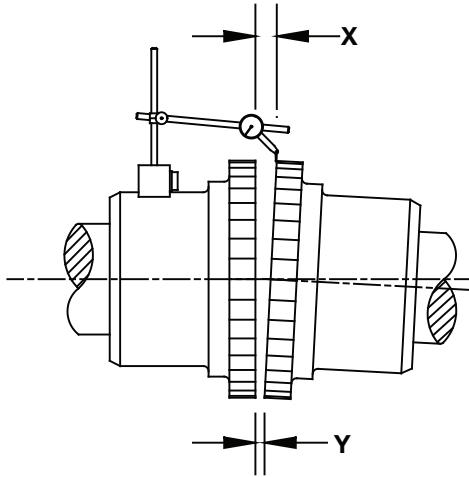

Figure 4 - Angular Misalignment

- Angular misalignment is measured by mounting a dial indicator on the reducer coupling hub with the probe contacting the mating coupling hub face (Figure 4). Slowly rotate the reducer shaft to determine the variation in gap between the ends of the hubs in both the vertical and horizontal planes. Vertical angular misalignment is corrected by adding or removing shims under the appropriate mounting pads on the reducer or baseplate. Horizontal angular misalignment is corrected by moving the shaft being aligned to alter the angular relation.

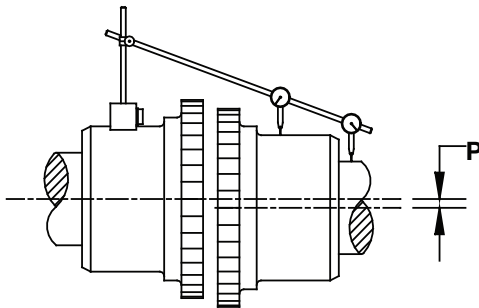

Figure 5 - Parallel Misalignment

- Parallel or offset misalignment is measured by mounting a dial indicator on the reducer coupling hub with the probe contacting outside diameter of the mating coupling hub or mating shaft (Figure 5). Slowly rotate the reducer shaft to determine the amount of parallel offset in both the vertical and horizontal planes. The difference in readings of the dial indicator gauge between any two locations 180 degrees apart will be double the amount of actual eccentricity.

$$\text{TIR (Total Indicator Reading)} = 2 \times \text{P}$$

Vertical offset misalignment is corrected by adding or removing shims under all mounting pads on the reducer or baseplate. Horizontal angular misalignment is corrected by laterally moving the shaft being aligned as needed.

- After alignment is completed, lubricate the couplings (if required) following the manufacturer's recommendations.
- Install high speed and low speed coupling guards in conformity with applicable safety standards for the location.

LUBRICATION

CAUTION: Unit is shipped without oil. Add proper amount of recommended lubricant before operating. Failure to observe this precaution could result in damage to or destruction of the equipment.

One oil sight plug is provided with the gear reducer. It is installed in the high side plug hole at the factory. Based on output speed, the plug may need to be relocated to the low side plug hole. Refer to Table 2 to identify the appropriate oil sight plug location for the application. The locations provided are appropriate for applications with the foot below the shafts and in the horizontal plane. Contact Dodge if the drive is being mounted on an incline. If the application requires the sight plug in the low side plug hole, switch the oil sight and plug between the two holes. Coat threads of both plugs with Loctite 564 or similar thread sealant prior to installation in housing.

Table 2 - Oil Level & Sump Capacity

Reducer Size	Output Speed (RPM)	Side Hole Location For Oil Sight Plug	Oil Capacity	
			U.S. Gallons	Liters
CR50	Above 250	Low	1.7	6.44
	250 & Below	High	2.7	10.2
CR60	Above 225	Low	2.7	10.2
	225 & Below	High	4.8	18.2
CR70	Above 205	Low	3.2	12.1
	205 & Below	High	5.6	21.2
CR80	Above 180	Low	4.6	17.4
	180 & Below	High	8.3	31.4
CR90	Above 150	Low	7.2	27.3
	150 & Below	High	12.2	46.2
CR100	Above 135	Low	7.7	29.1
	135 & Below	High	13.0	49.2
CR110	Above 122	Low	11.5	43.5
	122 & Below	High	19.3	73.1
CR120	Above 104	Low	14.9	56.4
	104 & Below	High	22.6	85.6
CR130	Above 95	Low	17.6	66.6
	95 & Below	High	28.0	106

Reducers with external pressure lube systems and heat exchangers will require additional oil. Run the gearmotor for 3 minutes to fill the heat exchanger and lube passages. Recheck the oil level and add oil as required.

Backstops

Internal backstops are lubricated with the gear oil. The backstop is not compatible with oils containing EP (extreme pressure) additives.

WARNING: Lubricant classes EP (extreme pressure) MUST NOT be used in reducers with backstops. Failure to observe this precaution could result in damage to or destruction of equipment and bodily injury.

Fill the reducer to the center of the oil site plug with recommended lubricant. A 25 micron filter is recommended to

filter oil before it enters the gearbox. Mineral based or synthetic oils with EP additives are the preferred lubricant for reducers without backstops. Mineral based or synthetic oils without EP additives are suitable for reducers with backstops. ISO viscosity recommendations based on operating conditions are provided in Table 3. Consult Mechanical Power Transmission Support for ambient conditions beyond those covered in Table 3.

Lubrication is extremely important to satisfactory operations. The proper oil level must be maintained at all times. Frequent inspections with the unit not running and allowing sufficient time to cool and for entrapped air to settle out, should be performed to verify oil level. Check oil level monthly.

Table 3 - Oil Viscosity Recommendations

ISO Grades For Ambient Temperatures of 15° to 60° F									
Output RPM	Reducer Size								
	CR50	CR60	CR70	CR80	CR90	CR100	CR110	CR120	CR130
Above 125	150	150	150	150	150	150	150	150	150
116-125	220	150	150	150	150	150	150	150	150
106-115	220	220	150	150	150	150	150	150	150
91-105	220	220	220	150	150	150	150	150	150
76-90	220	220	220	220	150	150	150	150	150
71-75	220	220	220	220	220	150	150	150	150
62-70	220	220	220	220	220	220	150	150	150
54-61	220	220	220	220	220	220	220	150	150
49-53	220	220	220	220	220	220	220	220	150
48 & Lower	220	220	220	220	220	220	220	220	220

ISO Grades For Ambient Temperatures of 50° to 125° F									
Output RPM	Reducer Size								
	CR50	CR60	CR70	CR80	CR90	CR100	CR110	CR120	CR130
Above 125	220	220	220	220	220	220	220	220	220
116-125	320	220	220	220	220	220	220	220	220
106-115	320	320	220	220	220	220	220	220	220
91-105	320	320	320	220	220	220	220	220	220
76-90	320	320	320	320	220	220	220	220	220
71-75	320	320	320	320	320	220	220	220	220
62-70	320	320	320	320	320	320	220	220	220
54-61	320	320	320	320	320	320	320	220	220
49-53	320	320	320	320	320	320	320	320	220
48 & Lower	320	320	320	320	320	320	320	320	320

Notes:

1. Assumes auxiliary cooling where recommended in the catalog.
2. Pour point of lubricant selected should be at least 10°F lower than expected minimum ambient starting temperature.
3. Special lubricants may be required for food and drug industry applications where contact with the product being manufactured may occur. Consult a lubrication manufacturer's representative for his recommendations.
4. For reducers operating in ambient temperatures between -22°F (-30°C) and 20°F (-6.6°C) use a synthetic hydrocarbon lubricant, 100 ISO grade or AGMA 3 grade (for example, Mobil SHC627). Above 125°F (51°C), consult DODGE Gear Application Engineering (864) 288-9050 for lubrication recommendation.
5. Mobil SHC630 Series oil is recommended for high ambient temperatures.

CAUTION: Too much oil will cause overheating and too little will result in gear failure. Check oil level regularly. Failure to observe this precaution could result in bodily injury and damage to equipment.

Under average industrial operating conditions using mineral oil, the lubricant should be changed every 2500 hours of operation or every 6 months, whichever occurs first. If using synthetic oils, the change interval can be increased to 8000 hours of operation or 18 months of service, whichever occurs first. Under extreme operating conditions, such as rapid rise and fall of temperature, dust, dirt, chemical particles, chemical fumes, or oil sump temperatures above 200°F, the oil should

be changed every 1 to 3 months, depending on severity of conditions. Drain reducer and flush with kerosene, clean magnetic drain plug and refill to proper level with new lubricant.

The performance of the new oil will be higher if a better job is done in draining the old oil from the reducer. A small amount of residual oil is usually not detrimental to performance. Never mix gear oils from different manufacturers or type. If changing oil brands or type, flush the geardrive by pouring a charge of the new oil into the gearbox and allow it to drain.

OIL VISCOSITY EQUIVALENCY CHART

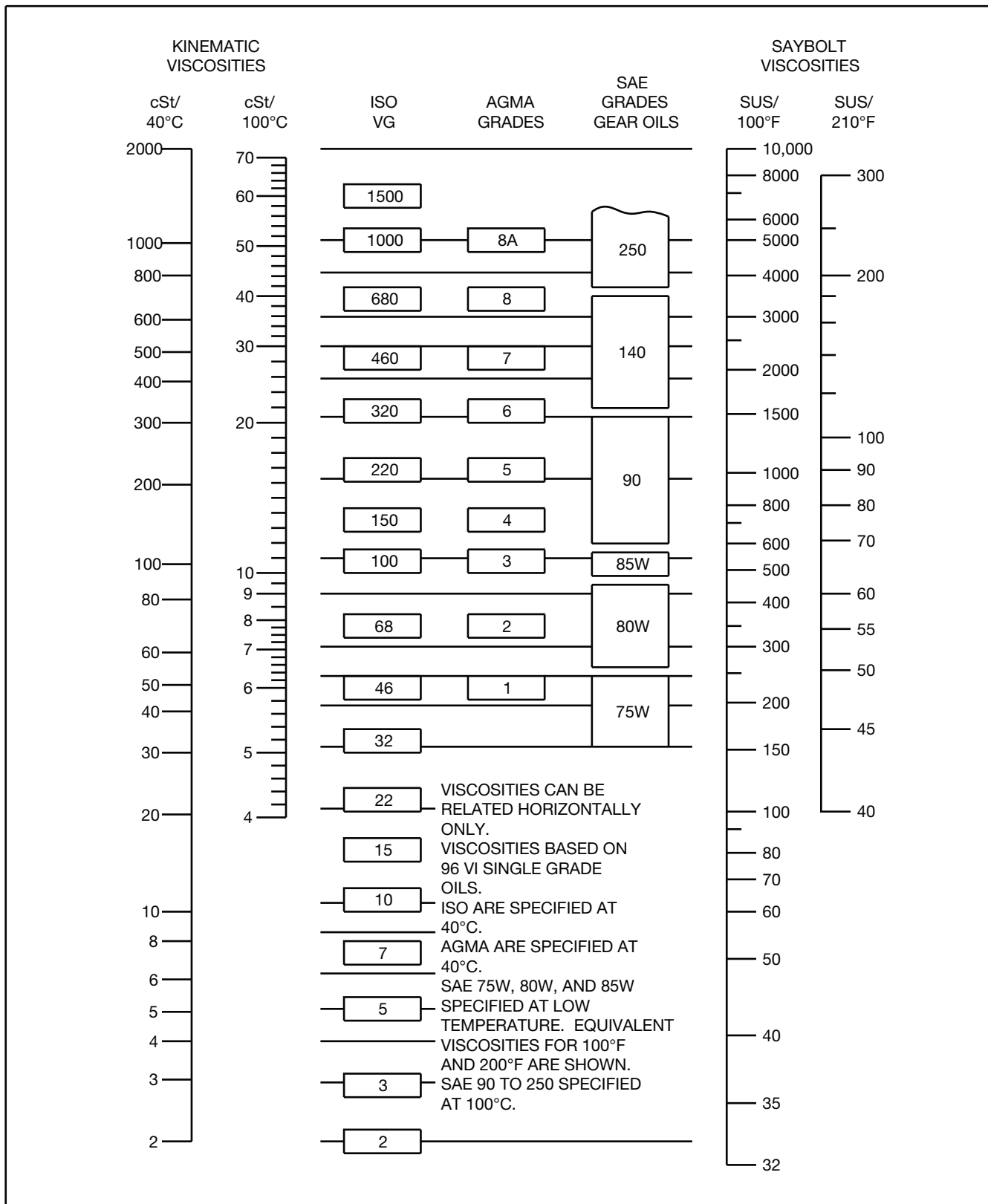

GREASED SHAFT SEALS

Grease packed shaft seals must be re-greased periodically based on the level of contaminants in the operating area. Under normal conditions re-grease the seals at every oil change. In dirty or dusty environments, the seals should be re-greased every 1 to 3 months depending on the severity of the operating condition. To re-grease seals, add fresh grease through the zerk fitting while slowly rotating the reducer input shaft. Grease will purge through a relief plug located approximately 180° away from the zerk fitting. Add grease till clean grease is purged through the relief plug.

DRAINING THE OIL

Change oil per the schedule in the lubrication section of this manual. Shut down the geardrive and follow lock out tag out procedures to prevent accidental startup. Remove the drain plug and completely drain or pump the oil into a suitable container. If it is suspected that the oil is contaminated, the reducer should be flushed by pouring a charge of oil equal to the fill amount and allow the oil to drain into a container. Thoroughly clean the magnetic drain plug.

OIL SAMPLING

Oil Sampling and analysis is a common preventative maintenance technique. It is recommended that an oil sample be provided to the lubricant supplier for analysis at the time of the oil change. A consistent sampling process is necessary to perform an oil condition trend analysis. A representative sample can be obtained as follows:

2. Operate the drive for an extended period to achieve operating temperature and evenly distribute contaminants.
3. Shut the drive down following lock out tag out procedures.
4. Open the drain plug and let several quarts drain off.
5. Collect a sample in a clean container (available from lubricant supplier).
6. The initial oil drained off can be returned to the sump or discarded and replaced with fresh oil.

Consideration should be given to setting up an oil sampling plan to determine the optimal lube change interval based on lube condition.

CAUTION: If your environment is especially high in moisture, dust and dirt, check the oil condition frequently. Take samples and check for condensation and sediment. Check the oil any time unusual ambient conditions might cause excessive condensation inside the gear case. Failure to do this may result in diminished life of the reducer.

CAUTION: If environmental conditions become severe with excessive amounts of dirt, dust, or moisture, contact your Dodge representative to determine whether other devices may be needed to protect your reducer.

START UP

After installation of the reducer is completed, check the following to ensure safe operation of the reducer.

1. Check couplings connecting reducer to the drive motor and/or driven equipment for proper alignment.
2. Check that the couplings are filled with the correct grade of grease as recommended by the coupling manufacture.
3. Check all mounting bolts, nuts, and screws to be sure they are tight.

4. Check that oil sight plug is in the correct hole per Table 2, and that oil is filled to the center of the sight plug.
5. Ensure that the oil viscosity is appropriate for the operating conditions per Table 3.
6. Ensure breather is installed.
7. Check direction of rotation of all components (refer to BACKSTOP section of this manual).
8. Ensure all safety guards are in place and properly installed.

CAUTION: Do not operate reducer with caps, covers, or guards missing. Failure to follow this may result in bodily injury.

PREVENTIVE MAINTENANCE

GENERAL - All maintenance and repair work should be carried out by trained personnel. Perform the following maintenance at the recommended intervals.

First day of operation

1. Check oil temperature – Sump temperature will vary based on operating conditions and cooling method. The gearbox is designed for a maximum oil sump temperature of 200 F (93 C). For water cooled heat exchangers, water flow rate can be adjusted to obtain the desired temperature. Flow rates in the higher range will reduce the oil sump temperature. Check with the cooler manufacturer to determine the allowable flow rates through the cooler.
2. Check for change in noise level
3. Check for oil leaks

After first month or 600 hrs of operation

1. Check oil for water content
2. Change oil
3. Check mounting hardware for tightness
4. Check for oil leaks
5. Clean and reinstall the magnetic drain plugs
6. Re-grease seals
7. Check coupling alignment

Periodically

1. Check oil level
2. Check for leakage
3. Check oil temperature for changes
4. Check for change in noise level
5. Change oil filter (if present)
6. Clean fan (if present)
7. Check for loose fasteners

Every 6 months or 2500 hours of operation

1. Sample oil and have analyzed for condition and contaminants
2. Change oil every 2,500 hours of operation for mineral oil with R&O additives
3. Change oil every 8,000 hours of operation for synthetic oils
4. Replace oil filter (if present)
5. Clean and reinstall magnetic drain plug
6. Check for leaks
7. Re-grease seals
8. Check mounting hardware for tightness
9. Check the cooling system

Oil Sampling Program

Oil change intervals may be extended providing an oil sampling and analysis program is in place. General guidelines for typical properties and contaminant levels are listed below. If an oil sample indicates any of the conditions listed, the oil and filter (if present) should be changed.

- Viscosity change: $\pm 15\%$ of starting ISO value
- Oxidation/TAN: Increase of 2 in TAN over starting value
- Water: > 500 ppm
- Iron: > 150 ppm
- Copper: > 50 ppm
- Silicon/Dirt: > 25 ppm
- Aluminum: > 20 ppm
- Typically a 4:1 ratio of iron to silicon indicates dirt contamination

The values listed are guidelines. Trends are just as important as actual numbers. Increased contaminate values would indicate internal component wear is beginning to occur. The reducer should be monitored more frequently and may need to be removed from service for repair.

GUIDELINES FOR LONG-TERM STORAGE

During periods of long storage, or when waiting for delivery or installation of other equipment, special care should be taken to protect a gear reducer to have it ready to be in the best condition when placed into service. By taking special precautions, problems such as seal leakage and reducer failure due to lack of lubrication, improper lubrication quantity, or contamination can be avoided. The following precautions will protect gear reducers during periods of extended storage:

Preparation and storage

1. Drain oil from the reducer. Add a vapor phase corrosion inhibiting oil (VCI-105 oil by Daubert Chemical Co.) in accordance with Table 5. Rotate the input shaft several times by hand.
2. Seal the unit airtight. Replace the vent plug with a standard pipe plug and wire the vent to the unit.
3. Cover all unpainted exterior parts with a waxy rust preventative compound that will keep oxygen away from the bare metal. (Non-Rust X-110 by Daubert Chemical Co. or equivalent)
4. The instruction manuals and lubrication tags are paper and must be kept dry. Either remove these documents and store them inside, or cover the unit with a durable waterproof cover which can keep moisture away.
5. Protect reducer from dust, moisture, and other contaminants by storing the unit in a dry area.
6. In damp environments, the reducer should be packed inside a moisture-proof container or an envelope of polyethylene containing a desiccant material. If the reducer is to be stored outdoors, cover the entire exterior with a rust preventative.
7. Every three months, rotate the reducer input shaft a few rotations by hand.

Table 5 - Quantities of VCI #105 Oil

Reducer Size	Volume
	Ounces / Milliliter
CR50	1 / 30
CR60	1 / 30
CR70	2 / 59
CR80	2 / 59
CR90	3 / 89
CR100	4 / 118
CR110	6 / 177
CR120	8 / 237
CR130	11 / 325

VCI #105 and #10 are interchangeable.

Placing the reducer into service

1. Fill the unit to the proper oil level using a recommended lubricant. The VCI oil will not affect the new lubricant.
2. Clean the shaft extensions with petroleum solvents.
3. Assemble the vent plug into the reducer housing.
4. Follow the installation instructions provided in this manual.

BACKSTOPS

The CR50 through CR70 reducers are suitable for adding a backstop in the field. The CR80 through CR130 sizes must be ordered with a backstop from the factory; backstop overrunning rotation is established during assembly and may be reversed in the field. Backstops are located below the output shaft extension on all sizes. Instructions for specific sizes are provided below. To prevent damage to the equipment, couplings should not be connected until motor direction of rotation is checked and is correct for the freewheeling rotation of the gear drive.

WARNING: To ensure that drive is not unexpectedly started, turn off and lock out or tag power source before proceeding. Remove all external loads from drive before removing or servicing drive or accessories. Failure to observe these precautions could result in bodily injury.

WARNING: All work should be performed in a clean environment and care should be taken to prevent the ingress of contaminants into the gear reducer and backstop assembly. Failure to observe these precautions could result in premature failure of reducer and backstop.

Installation of Backstop on CR50 through CR70 sizes

1. Orient the gear reducer so the output shaft is pointing up.
2. Remove backstop shaft cover and O-rings. Jacking screw holes are provided to assist with removal.
3. Remove metal shims from behind bearing cup and wire together for future reference.
4. Clean the face of the gearbox to remove any contamination from the cover mounting surface. It is important that the reducer and backstop be kept free from contamination during the backstop installation/servicing process.
5. Remove backstop from packaging. The backstop includes an inner key, inner race, outer sprag assembly, and outer key.
6. Install inner key into keyway on backstop stub shaft.
7. Coat the backstop stub shaft with a thin film of oil and install the backstop inner race onto the shaft. Install snap ring for axial retention.

8. Install the backstop outer key into the backstop carrier and coat the bore with a thin film of oil.
9. Identify orientation of backstop in the carrier to achieve the desired overrunning direction. Note that reversing the backstop end-for-end changes the direction of the arrow. The shaft will rotate in the same direction as the arrow on the backstop. The carrier will be mounted with the dowel hole on the reducer side. Do not install dowel at this time. Install the backstop into the carrier with the rotation arrow pointing in the desired direction of free rotation. Ensure that parts are not cocked relative to each other. Lightly tap the backstop outer edge until it slides freely in the bore. Do not use excessive force.
10. Measure the thickness of shims removed in step 2. Install a pack of shims that is 0.010"-0.015" thinner than the shims removed. Locate the thickest shim adjacent to the bearing cup. Thinner shims should be sandwiched between the thicker shims.
11. Apply a thin coat of oil to the backstop sprags, inner race, and housing bore.
12. Gently slide the backstop and carrier onto the inner race in the housing bore while rotating the shaft in the overrunning direction. Shaft can be rotated by rotating the input shaft. Do not use excessive force during assembly.
13. Install cover and 4 capscrews. Tighten to the values listed in Table 1.
14. Insert capscrew provided through hole in cover and engage threads in shaft. Snug capscrew to remove clearance in threads. Rotate and lightly tap capscrew to seat lower bearing.
15. Mount magnetic base dial indicator on housing with plunger on capscrew head parallel to shaft axis. Set the indicator to zero. Pry under capscrew head to measure bearing end play. The bearings need to be adjusted to have the amount of endplay shown in Table 6 under "LS Pinion Shaft". Remove backstop assembly and adjust shims as necessary to achieve required setting. Adding shims will reduce float, removing shims will increase float.
16. For final assembly, press dowel pin into backstop carrier and install o-ring into counterbore on carrier mounting surface. Apply a thin bead of Loctite 515 or equivalent at the housing to carrier joint and the carrier to cover joint. Bead must full encircle the fastener holes and the outer edge of the oil feed slot in the cover.
17. Install all fasteners and tighten to the values provided in Table 1.
18. Take final measurement of bearing end play.
19. Coat pipe plug threads with sealant and install in cover.

Changing Overrunning Rotation of Backstop on CR80 through CR130 sizes

1. Orient the gear reducer so the output shaft is pointing up.
2. Remove all backstop cover fasteners and the backstop cover. Take care to protect the o-ring sealing the face between the cover and the backstop. Note that the outer race of the backstop is no longer retained to the reducer housing. On the CR80 and CR120, the backstop adapter is also no longer retained.
3. Remove the backstop outer race by pulling it axially while rotating in the overrunning direction. Retain the outer race in a clean location for reassembly later. Note that there is an o-ring in the face of the backstop adapter, ensure it is in place during reassembly.
4. There is a snap ring located on the shaft to axially retain the backstop inner race on the shaft. Remove the snap ring and retain for reassembly later.
5. Note that reversing the backstop inner race end-for-end changes the overrunning direction of the backstop. The shaft will rotate in the same direction as the arrow on the backstop. Remove the backstop inner race assembly from the shaft and flip it end-for-end. Carefully align the backstop inner race to the shaft, engage the key and reassemble to the shaft. Ensure that parts are not cocked relative to each other. Lightly tap the backstop inner race hub (not the sprag assembly) until it slides freely on the shaft. Do not use excessive force.
6. Ensure that the o-ring is in the groove of the adapter face and lightly coated with oil or grease.
7. Assemble the backstop outer race to the inner race while rotating the race in the overrunning direction. The outer race will locate on a pilot diameter on the adapter.
8. Reinstall the end cover with o-ring. Grease applied to the o-ring groove will help retain the o-ring during installation. Install the class 10.9 cover fasteners and hardened washers. Tighten to the torques provided in the Table 7.

Table 6 - Bearing End-Play Settings

Bearing End-Play Settings for Ratios 2.25:1 Through 31.4:1 (Inches)										
Shaft Assembly	Ratio	Reducer Size								
		CR50	CR60	CR70	CR80	CR90	CR100	CR110	CR120	CR130
Input Shaft	ALL	0.001-0.003	0.001-0.003	0.002-0.004	0.003-0.005	0.003-0.005	0.004-0.006	0.004-0.006	0.005-0.007	0.006-0.008
LS Pinion Shaft	ALL	0.001-0.003	0.002-0.004	0.002-0.004	0.002-0.004	0.004-0.006	0.004-0.006	0.033-0.043	0.039-0.049	0.037-0.047
Output Shaft	2.25 - 4.13	0.001-0.003	0.001-0.003	0.001-0.003	-	-	-	-	-	-
	5.06 & HIGHER	(0.003-0.005)*	(0.003-0.005)*	(0.003-0.005)*	(0.004-0.006)*	(0.004-0.006)*	(0.005-0.007)*	0.048-0.058	0.058-0.068	0.063-0.073
* INDICATES PRELOAD. THIS IS THE VALUE OF SHIMS TO BE ADDED FROM NO END-PLAY / NO PRELOAD CONDITION.										
Bearing End-Play Settings for Ratios 38.44:1 Through 194.6:1 (Inches)										
Shaft Assembly	Ratio	Reducer Size								
		CR50	CR60	CR70	CR80	CR90	CR100	CR110	CR120	CR130
Input Shaft	ALL	0.001-0.003	0.001-0.003	0.001-0.003	0.001-0.003	0.001-0.003	0.001-0.003	0.001-0.003	0.001-0.003	0.001-0.003
1st Stage Gear Shaft	ALL	0.001-0.003	0.001-0.003	0.001-0.003	0.001-0.003	0.001-0.003	0.001-0.003	0.001-0.003	0.001-0.003	0.001-0.003
LS Pinion Shaft	ALL	0.001-0.003	0.001-0.003	0.001-0.003	0.001-0.003	0.001-0.003	0.001-0.003	0.033-0.043	0.039-0.049	0.037-0.047
Output Shaft	ALL	(0.003-0.005)*	(0.003-0.005)*	(0.004-0.006)*	(0.004-0.006)*	(0.005-0.007)*	(0.006-0.008)*	0.048-0.058	0.058-0.068	0.063-0.073
* INDICATES PRELOAD. THIS IS THE VALUE OF SHIMS TO BE ADDED FROM NO END-PLAY / NO PRELOAD CONDITION.										

Table 7 - Backstop Cover Tightening Torques (Coarse Threads Series)

Nominal Diameter mm	Reducer Sizes	Class 10.9 Tightening Torque lb-ft [Nm]
10	CR80, CR90	40 [54]
12	CR100, CR110	70 [94]
16	CR120, CR130	170 [235]

TOP MOTOR MOUNTS

Assembly Instructions

Refer to Figures 6 and 7 while installing the top motor mount. Remove the upper four bolts (10) and (13) from the input and output covers.

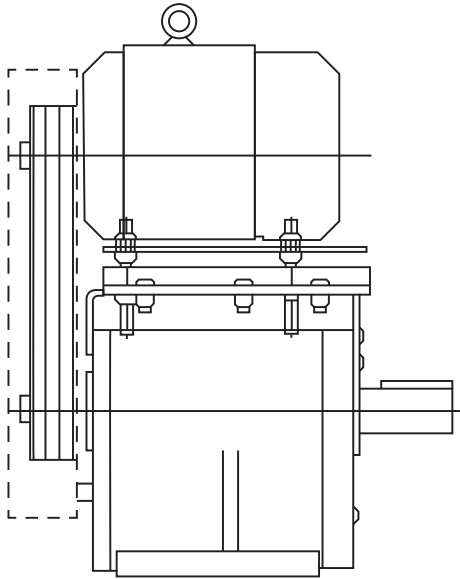

Figure 6 - Top Motor Mount

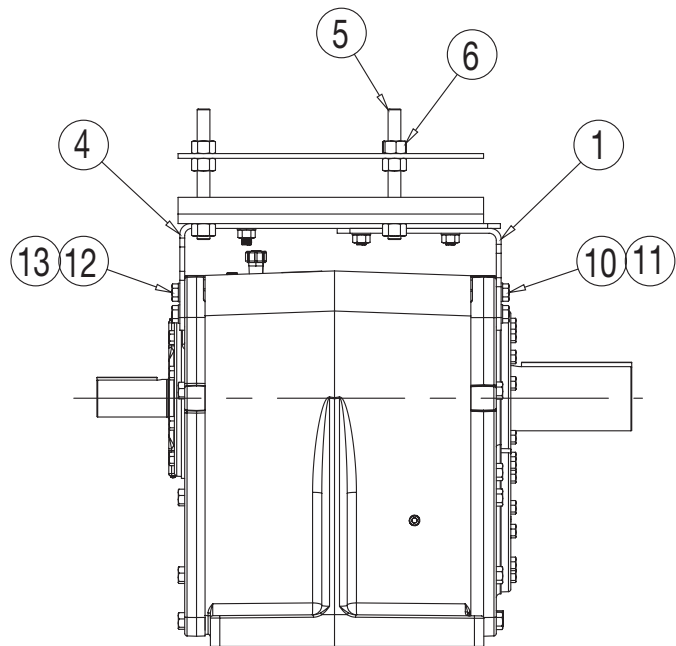
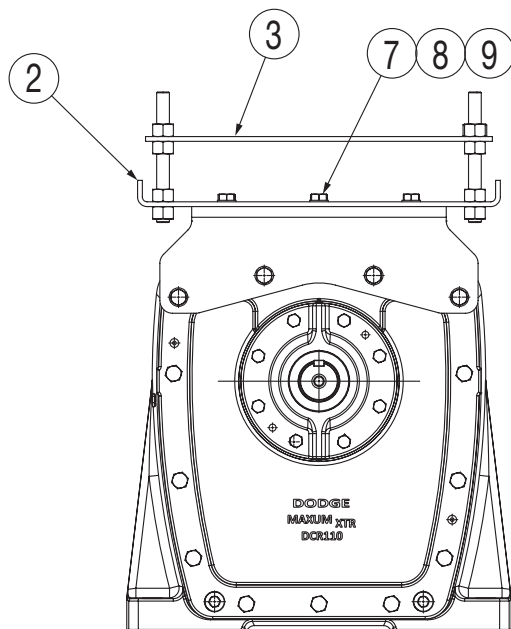

Figure 7 - Top Motor Mount Parts Identification

Identify the output end motor mount support (1). The CR50 through CR70 sizes use a common support for the input and output end of the reducer. The CR80 and larger sizes have unique supports for the output end. The rear motor mount support for the CR80 and larger will be the shorter of the two. If the cover bolts furnished with the motor mount kit are of different lengths, the longer bolts go on the output end. Assemble the output end motor mount support (1) to the reducer using the longer bolts (10) and flat washers (11, if furnished with kit) and tighten finger tight. Do not fully tighten at this time.

- CR50 – Rear support overhangs output shaft extension.
- CR60-CR130 - Rear support overhangs the top of reducer (as shown in Figure 7).

Assemble the input end motor mount support (4) to the reducer using the remaining bolts (13) and flat washers (12, if furnished with kit) and tighten finger tight. On the CR80 and larger sizes the front support will overlap the rear support as shown in Figure 7. Do not fully tighten at this time.

Place the “U” shaped or flat (sizes CR60 & CR70) bottom motor mount plate (2) on top of the supports (1) and (4) with the legs of the “U” up and with the end stamped “INPUT END” toward the input shaft. Locate the slots that best align with the holes in the input and output supports. Insert bolts (7), washers (8) and nuts (9). Tighten the nuts finger tight.

Now tighten the bolts (10) and (13) holding the output end support (1) and the input end support (4) to the reducer. Tighten bolts to the torques specified for the fastener diameter in Table 8.

Table 8 – Motor Mount Tightening Torques (coarse thread series)

Inch Stud & Nuts		Metric Fasteners		
Nominal Diameter	Grade SAE 2 Tightening Torque	Nominal Diameter	Class 8.8 Tightening Torque	
in.	lb-ft	mm	lb-ft	Nm
0.750	78	M12	47	[64]
1.000	190	M16	120	[160]
		M20	240	[310]
		M24	420	[535]

Place four adjusting screw studs (5) in the “U” shaped bottom plate (2) and secure each with two nuts (6). Thread an additional nut (6) part way onto the adjusting screw (5). Place the flat motor plate (3) over the adjusting screws with the input end toward the input side of the reducer. The input end of the flat motor plate (3) is the end with the smallest motor holes located closest to the edge. Thread on the remaining four nuts (6). Adjust the nuts (6) until the flat motor plate is level or parallel to the reducer input shaft.

Place the motor on top of the flat motor plate and bolt in place. Tighten the motor mounting fasteners to the torques specified in Table 1.

Slide the motor sheave onto the motor shaft as far as it will go. Slide the reducer sheave onto the reducer shaft as far as it will go. Roughly align the sheaves by sliding the “U” shaped bottom plate (2) forward or backwards until the sheaves are in approximate alignment. Tighten the bolts (7) and nuts (8) to the torque specified in Table 8.

Align the sheaves vertically by placing a straight edge across the face of each sheave. Alignment should be rechecked after the sheaves are fully tightened to the shaft and readjusted as necessary to ensure alignment and prevent interference with stationary objects (i.e., fan guard, motor mount). Make sure the sheaves remain as far on their shafts as possible so as to minimize bearing loads on both the motor and the reducer caused by belt tension.

Install and properly tension the V-belt(s). The use of a DODGE V-belt tension tester will assist in obtaining the proper tension. Do not over tension the belts, which will cause excess loads on the motor and reducer bearings, nor under tension the belts which will cause reduced belt life.

Recheck the horizontal alignment of the motor shaft by placing a straight edge across the face of the motor sheave and noting where it meets the reducer sheave. Correct any misalignment by adjusting the flat motor plate via the input and/or output adjusting screws until the motor shaft and reducer shaft are parallel. Recheck belt tension. Tighten the adjustment screw nuts to the torques specified in Table 8. Install the belt guards.

WARNING: Ensure that all guards are properly installed before proceeding. Exercise extreme care to avoid contacting rotating parts. Failure to observe this precaution could result in severe bodily injury.

SCOOPS – Assembly Instructions

WARNING: Proper guarding for motor, reducer coupling, and the output shaft must be provided by the user. Failure to observe this precaution could result in bodily injury.

Scoops for motor frames 320 and smaller are a bolted design where parts (1), (2) and (3) are assembled together as part of the installation process (Refer to Figure 8). Scoops for motor frames 360 and larger are a fabricated design where parts (1), (2), and (3) are welded together at the factory and arrive as a single part within the scoop kit. With this in mind, the assembly process varies slightly based on motor frame size.

Motor Frames 320 and Smaller

1. Refer to Table 9 and Figures 8 & 9 during assembly of the scoop motor bracket for parts identification and important assembly information. Place the left (1) and right (2) side plates and the bottom plate (3) in front of the input side of the reducer. Orient the bottom plate (“U” up or “U” down) based on Table 9. Identify and remove the reducer cover bolts necessary for installation of the side plates. Remove only those cover bolts or you may rupture the oil seal between the end cover and reducer housing.
2. Assemble the side plates (1) and (2) onto the reducer using the longer bolts (4) and flat washers (5) furnished with the scoop kit. Do not fully tighten the bolts at this time as you will need sideways movement to assemble the bottom plate.
3. Using bolts (6), washers (7) and nuts (8) furnished with the kit, bolt the bottom plate to the side plates using the correct holes as indicated in Table 9 and Figure 8. Do not fully tighten the bolts at this time.
4. Refer to the coupling installation manual to identify the appropriate coupling gap. Add the coupling hub overhang as specified in Table 9 to determine the correct distance between shaft ends.
5. Lower the motor into position with the shaft ends separated by the distance determined in step 4. Adjust the bottom plate until the motor mounting bolts can be inserted through the motor feet and the bottom plate. Tighten the bolts (6) holding the bottom plate to the side plates and bolts (4) holding the side plates to the reducer to the recommended tightening torques specified in Table 1.
6. Move the motor out of the way.
7. If a shaft driven fan is being used, it should be installed at this time using the fan installation instructions.
8. The coupling hub can now be mounted on the reducer shaft with the hub overhang as specified in Table 9. Refer to the coupling installation manual for additional information. The mating coupling hub should be mounted on the motor shaft at this time.
9. Align the motor to the reducer following the coupling installation instructions as a guide. Tighten the motor foundation fasteners to the tightening torques specified in Table 1.
10. Install the coupling guard to cover the rotating elements.

Table 9 - Scoop Assembly Information

REDUCER SIZE	MOTOR FRAME	"D" (in)	MOUNTING HOLES	"U" OPENS	DESIGN NUMBER	REDUCER COUPLING HUB OVERHANG (IN)							
						RAPTOR COUPLING				GRID-LIGN COUPLING			
						DCR	DCR W/ FAN	TCR	TCR W/ FAN	DCR	DCR W/ FAN	TCR	TCR W/ FAN
CR50	140	3.50	A	DOWN	1	---	---	---	---	---	---	---	---
	180	4.50	B	DOWN	1	---	0.25	---	---	---	0.40	---	---
	210	5.25	A	UP	1	---	0.25	---	---	---	0.40	---	---
	250	6.25	B	UP	1	---	0.45	---	---	---	0.40	---	---
	280	7.00	A	UP	2	---	---	---	---	0.40	0.85	0.40	---
	320	8.00	B	UP	2	---	---	---	---	---	0.85	---	---
CR60	140	3.50	A	UP	3	---	---	---	---	---	---	0.12	---
	180	4.50	B	UP	3	---	---	---	---	---	---	0.37	---
	210	5.25	C	UP	3	---	0.39	---	---	---	0.37	0.31	---
	250	6.25	D	UP	3	---	0.38	---	---	0.47	0.37	0.12	---
	280	7.00	E	UP	3	---	0.56	---	---	---	0.59	0.37	---
	320	8.00	F	UP	3	---	0.56	---	---	---	0.70	---	---
	360	9.00	WELDED SCOOP			---	---	---	---	0.37	1.23	---	---
CR70	180	4.50	A	UP	4	---	---	---	---	---	---	0.12	---
	210	5.25	B	UP	4	---	---	0.16	---	---	---	---	---
	250	6.25	C	UP	4	---	---	0.25	---	---	0.12	---	---
	280	7.00	D	UP	4	---	---	---	---	---	0.12	0.12	---
	320	8.00	E	UP	4	---	---	0.16	---	---	0.12	0.12	---
	360	9.00	WELDED SCOOP			---	0.16	---	---	---	0.37	0.37	---
CR80	210	5.25	A	UP	5	---	---	---	---	---	---	---	---
	250	6.25	B	UP	5	---	0.21	---	---	---	---	---	---
	280	7.00	C	UP	5	---	---	---	---	---	0.37	---	---
	320	8.00	D	UP	5	---	0.25	---	---	---	0.57	---	---
	360	9.00	WELDED SCOOP			---	0.44	---	---	---	0.67	---	---
	400	10.00	WELDED SCOOP			---	---	---	---	---	0.89	---	---
CR90	210	5.25	A	UP	6	---	---	---	---	---	---	---	---
	250	6.25	B	UP	6	---	---	---	---	---	---	---	---
	280	7.00	C	UP	6	---	---	---	---	---	---	---	---
	320	8.00	D	UP	6	---	---	---	---	---	0.40	---	0.65
	360	9.00	WELDED SCOOP			---	---	---	---	---	---	---	1.15
	400	10.00	WELDED SCOOP			---	0.69	0.44	0.13	---	0.65	---	1.62
	440	11.00	WELDED SCOOP			---	0.88	---	---	---	1.00	---	---
CR100	250	6.25	A	UP	7	---	---	---	---	---	---	---	---
	280	7.00	B	UP	7	---	---	---	---	---	---	---	---
	320	8.00	C	UP	7	---	---	---	0.40	---	---	---	0.56
	360	9.00	WELDED SCOOP			---	0.56	---	---	---	0.56	---	1.00
	400	10.00	WELDED SCOOP			---	0.56	---	---	---	0.56	---	0.56
	440	11.00	WELDED SCOOP			---	0.56	---	---	---	1.12	---	0.37
CR110	250	6.25	A	UP	8	---	---	---	---	---	---	---	---
	280	7.00	B	UP	8	---	---	---	---	---	---	---	---
	320	8.00	C	UP	8	---	---	---	---	---	---	---	---
	360	9.00	WELDED SCOOP			---	---	---	---	---	---	---	---
	400	10.00	WELDED SCOOP			---	---	---	---	---	---	---	1.40
	440	11.00	WELDED SCOOP			0.72	0.31	0.36	---	---	0.62	---	0.37
CR120	250	6.25	A	UP	9	---	---	---	---	---	---	0.25	---
	280	7.00	B	UP	9	---	---	---	---	---	---	0.25	---
	320	8.00	C	UP	9	---	---	---	---	---	---	0.12	---
	360	9.00	WELDED SCOOP			---	---	---	0.25	---	---	---	1.00
	400	10.00	WELDED SCOOP			---	0.25	---	0.55	---	1.25	---	1.04
	440	11.00	WELDED SCOOP			---	0.35	0.50	---	---	0.56	0.12	1.46
CR130	280	7.00	A	UP	10	---	---	---	---	---	---	0.65	---
	320	8.00	B	UP	10	---	---	---	---	---	---	0.65	---
	360	9.00	WELDED SCOOP			---	---	---	---	---	---	---	1.12
	400	10.00	WELDED SCOOP			---	---	---	---	---	---	---	1.12
	440	11.00	WELDED SCOOP			---	---	---	0.43	---	0.65	---	1.50

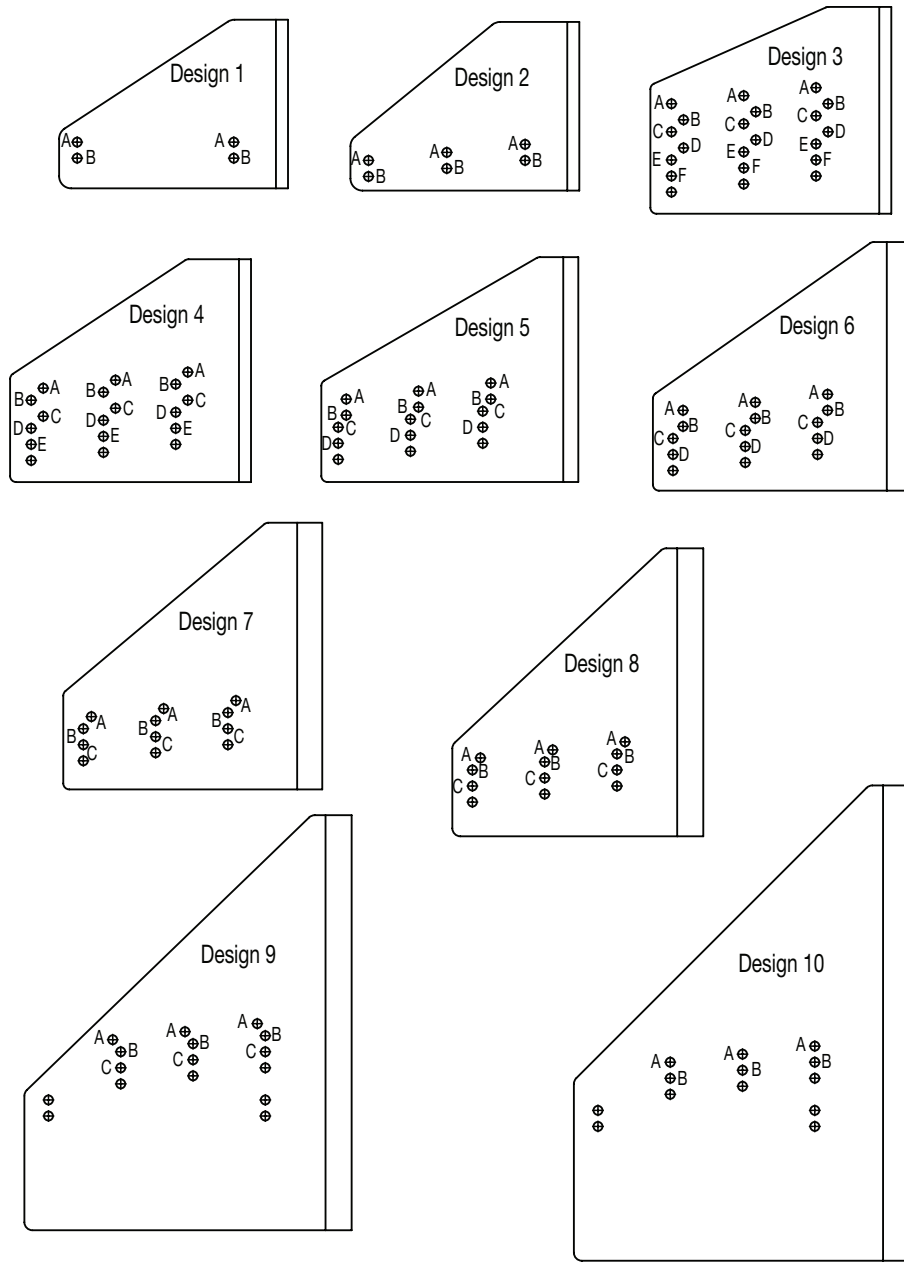

Figure 8 - Side Plate Hole Locations

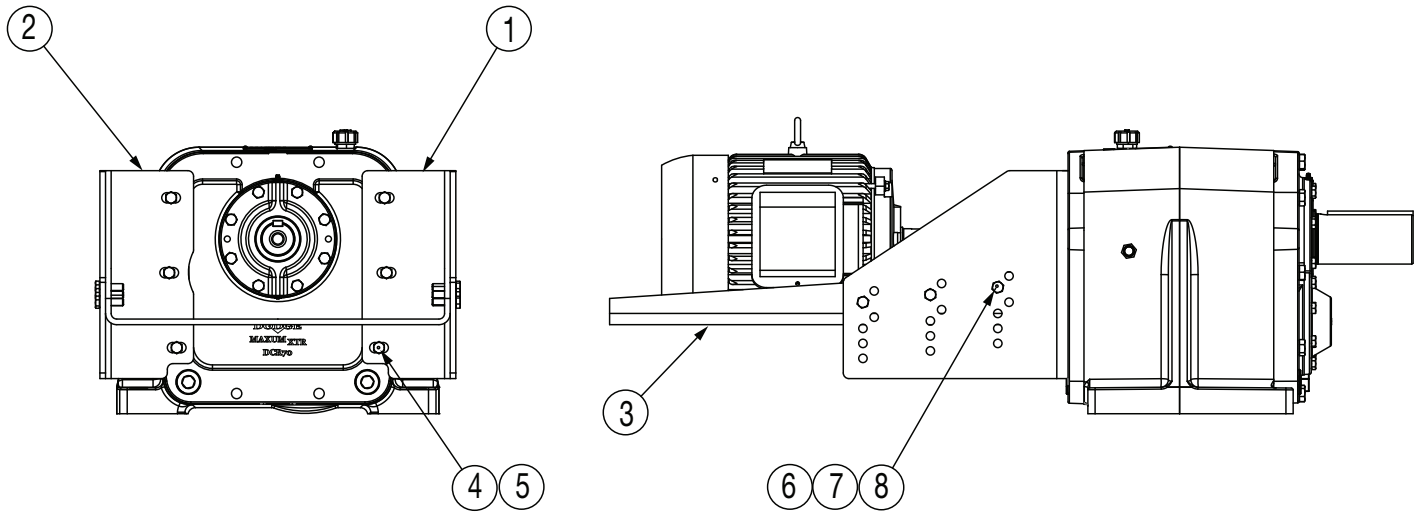

Figure 9 - Scoop Parts Identification

Motor Frames 360 and Larger

1. Refer to Table 9 and Figures 8 & 9 during assembly of the scoop motor bracket for parts identification and important assembly information. Place the fabricated scoop consisting of parts (1), (2), and (3) in front of the input side of the reducer. Identify and remove the reducer cover bolts necessary for installation of the fabricated scoop. Remove only these cover bolts or you may rupture the oil seal between the end cover and reducer housing.
2. Assemble the fabricated scoop onto the reducer using the longer bolts (4) and flat washers (5) furnished with the scoop kit. Care should be taken to center the scoop on the reducer; this will provide the most clearance in the motor foundation fasteners and make coupling alignment easier later. Tighten the bolts (4) to the tightening torques specified in Table 1.
3. If a shaft driven fan is being used, it should be installed at this time using the fan installation instructions.
4. The coupling hub can now be mounted on the reducer shaft with the hub overhang as specified in Table 9. Refer to the coupling installation manual for additional information. The mating coupling hub should be mounted on the motor shaft at this time.
5. Align the motor to the reducer following the coupling installation instructions as a guide. Tighten the motor foundation fasteners to the tightening torques specified in Table 1.
6. Install the coupling guard to cover the rotating elements.

SHAFT DRIVEN COOLING FANS - Installation Instructions

1. Refer to Table 10 and Figure 10 for the proper "NA" dimension to use in locating the fan hub on the input shaft. Refer to Figure 11 for parts identification.

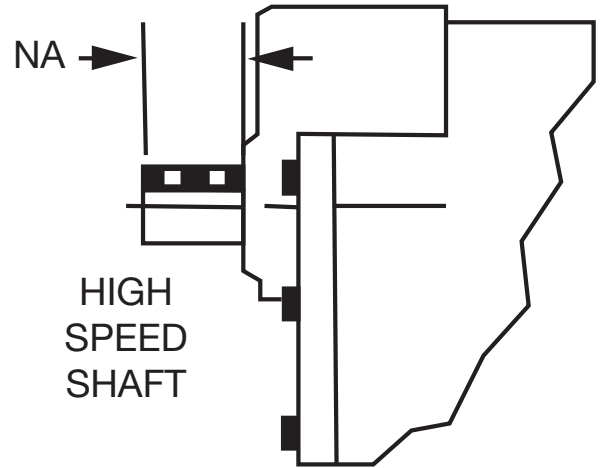

Figure 10 - Fan "NA" Dimensions

Table 10 - Fan "NA" Dimensions

Reducer Size	Fan "NA" Dimension	
	inch	mm
	DCR	TCR
	Double Reduction	Triple Reduction
CR50	1.77	---
CR60	1.86	---
CR70	2.56	---
CR80	2.74	---
CR90	3.00	1.85
CR100	3.08	1.99
CR110	3.02	2.13
CR120	3.70	2.46
CR130	4.12	2.39

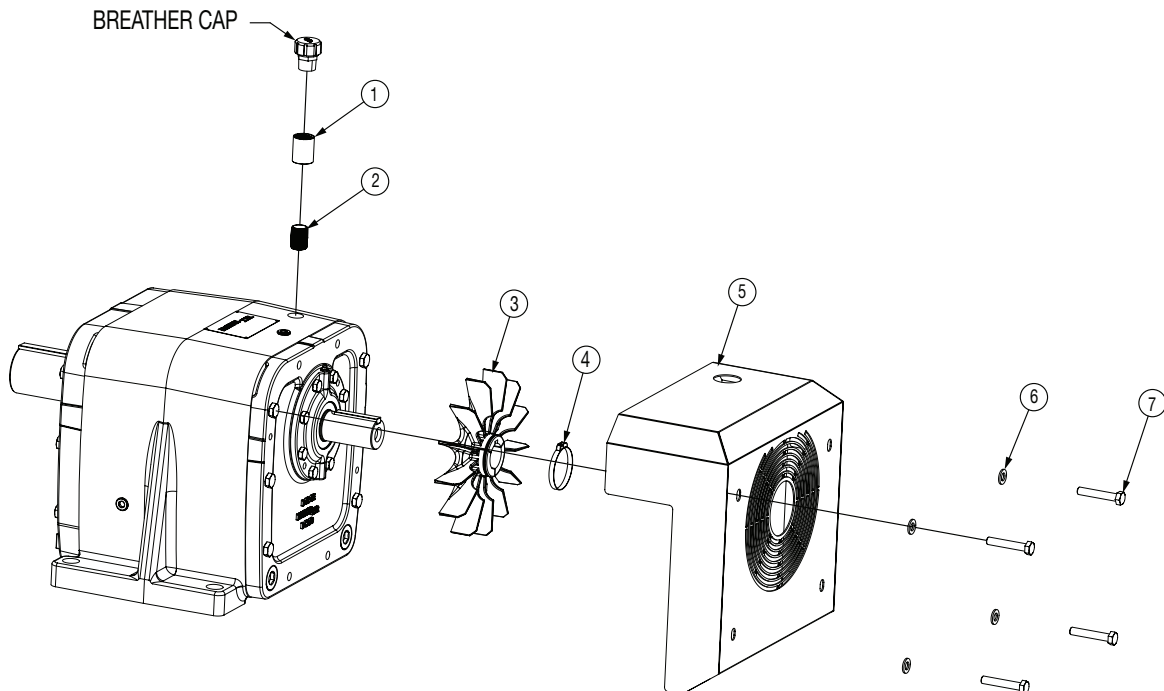

Figure 11 - Fan Parts Identification

- Remove the breather cap from the reducer housing. Apply a thread sealant to the pipe nipple (2) and install in the housing. Apply thread sealant to the upper threads and install the coupling (1) into the pipe nipple. Install the breather cap into the coupling (1).
- Hold the fan cover (5) up to the input end of the reducer to determine which reducer bolts must be removed. Remove these bolts.
- Ensure that the input shaft key is installed in the keyway flush with the end of the shaft. Slide the fan (3) onto the input shaft to the “NA” dimension provided in Table 10. Tighten the fan clamp or setscrew (4) to the tightening torque provided in Table 11 below. Rotate the fan by hand to check for any interference with the fan blades.

Table 11 - Setscrew Tightening Torque

Double Reduction			Triple Reduction		
Reducer size	Tightening Torque		Reducer Size	Tightening Torque	
	in-lb	Nm		in-lb	Nm
DCR50	14	1.6	TCR50	---	---
DCR60	14	1.6	TCR60	---	---
DCR70	14	1.6	TCR70	---	---
DCR80	25	2.8	TCR80	---	---
DCR90	25	2.8	TCR90	25	2.8
DCR100	25	2.8	TCR100	25	2.8
DCR110	25	2.8	TCR110	25	2.8
DCR120	25	2.8	TCR120	25	2.8
DCR130	25	2.8	TCR130	25	2.8

- Assemble the cover (5) to the input end of the reducer and secure with bolts (7) and flat washers (6). Adjust the fan cover (5) until the radial clearance between the fan hub (3) and the cover (5) is approximately equal all the way around. The fan cover should be flush with the end of the hub. Tighten the cover mounting bolts (7) to the tightening torque provided in Table 1.
- Rotate the shaft fan by hand to check for interference with the fan blades.

SLIDE BASES – Assembly Instructions

Refer to Figure 12 for slide base parts identification. The MaxumXTR reducer slide base positions the reducer, providing simplified installation of belt and chain drives.

The slide base (1) should be installed on a flat and level surface. If the slide base is installed on a concrete foundation, steel mounting pads should be grouted into the concrete at each of the four mounting holes. The slide base (1) should be shimmed until the top surface where the reducer mounts is flat and level. Tighten the foundation fasteners that secure the slide base to the foundation to the tightening torques specified in Table 1.

Mount the reducer to the slide base using the four mounting bolts (3), a flat washer (4) on top of the reducer foot and a lockwasher (5), and nut (6) underneath the slide base. Tighten the bolts finger tight. Adjust the belt or chain tension using the adjusting screws (2). Tighten the reducer mounting bolts (3) to the tightening torque specified in Table 1.

When a change in reducer position is desired, simply loosen the reducer mounting bolts (3) and slide the reducer by using the adjusting screws (2) provided. After the desired belt or chain tension is obtained, retighten the reducer mounting bolts (3) to the tightening torques specified in Table 1.

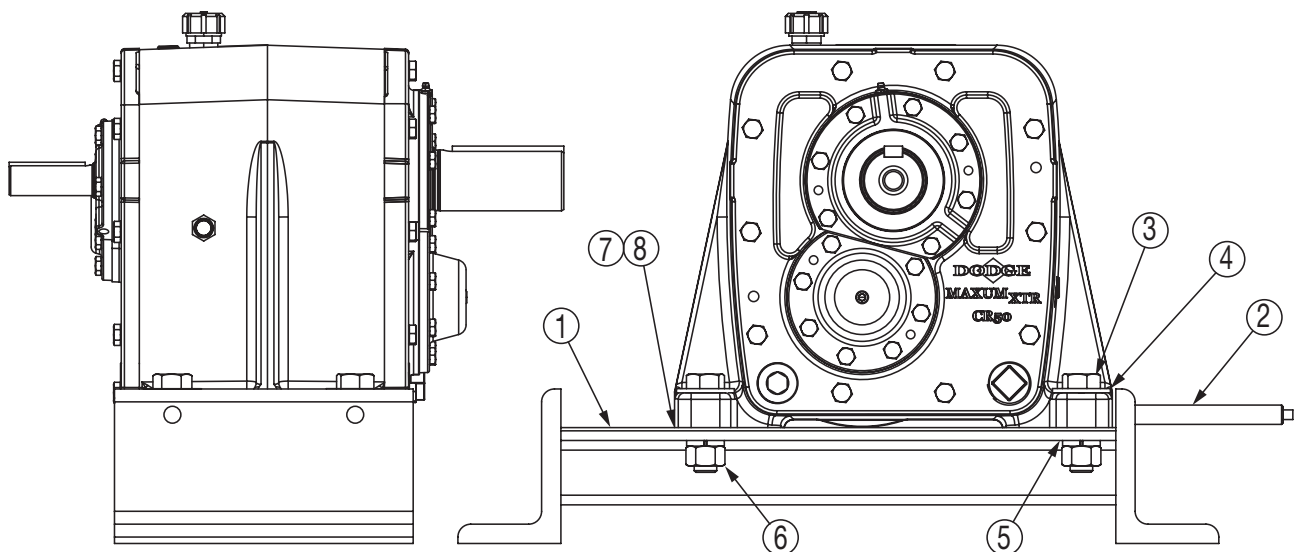

Figure 12 - Slide Rail Parts Identification

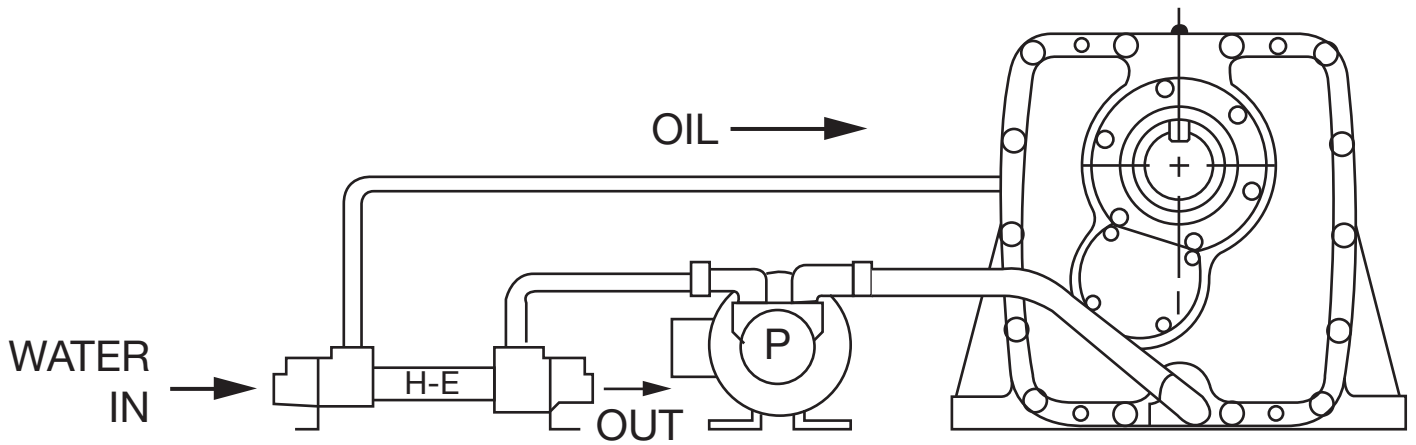

Figure 12 - Heat exchanger

HEAT EXCHANGERS

Reducers supplied with water cooled heat exchangers, Figure 13, should be piped to the cooling water lines and correct flow of coolant observed. Control devices should be wired and checked for correct operation. Check pipes periodically for sediment build up from the water. Clean if necessary.

It is recommended to install a pressure transducer to monitor the oil pressure at the inlet to the gear case. The oil pressure switch should be set to alarm if pressure is below 5 psi. High operating pressure is not required. Water flow to the cooler should be set

to provide a sump temperature between 150 to 180°F. Check with the cooler manufacturer to determine the allowable flow rates through the cooler. If the cooler is provided by Dodge, a recommend flow rate will be provided. Water discharge should be into an open drain.

CAUTION: Final topping off of lubricant should be done after the heat exchanger system has run for approximately 3 minutes. Failure to do this may result in low oil level, reduced splash, and failure of reducer.

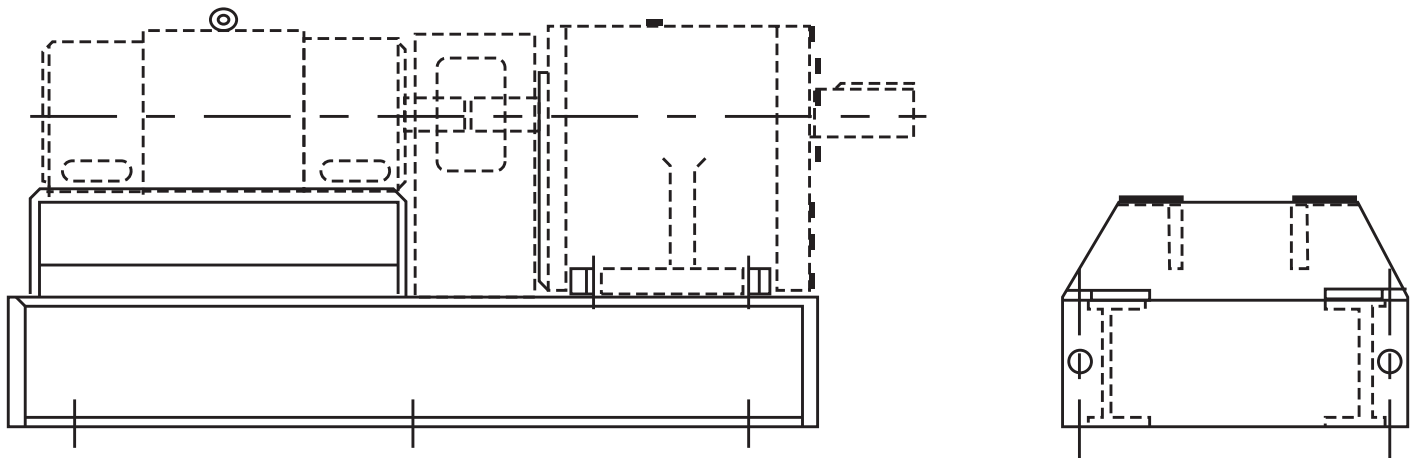
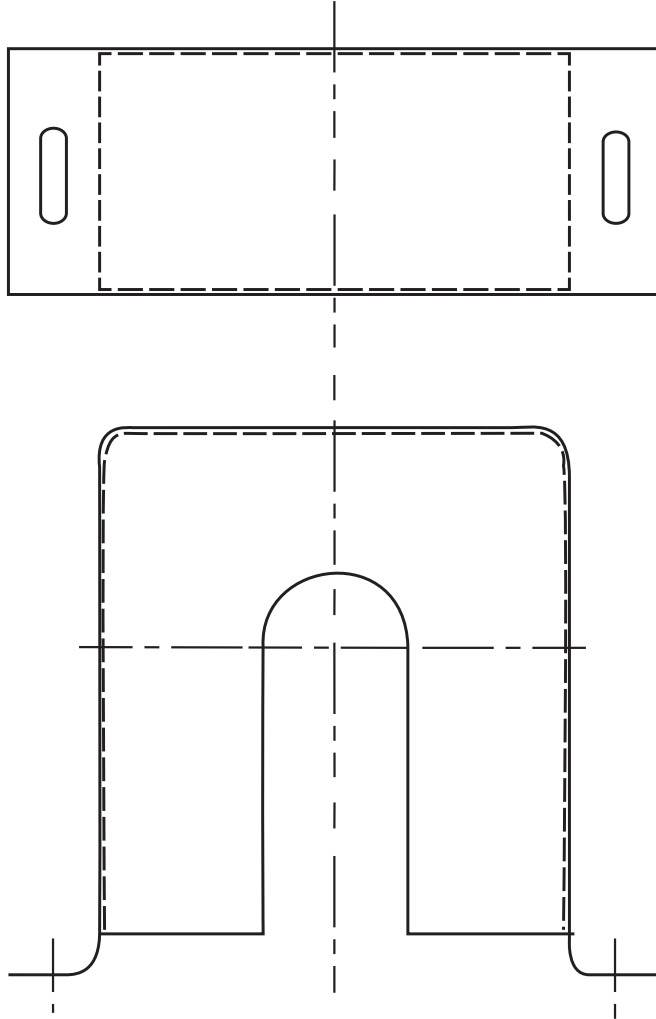

Figure 14 - Heavy Duty Baseplate

HEAVY DUTY BASEPLATES

Heavy duty baseplates, Figure 14, are rigid steel fabrications providing a sturdy mounting base for motor, coupling and reducer assemblies. This accessory is recommended for large motors where the motor weight exceeds the reducer weight or 700 pounds and for all variable speed DC or AC applications regardless of the motor weight.

Consult Dodge for baseplate dimensions.



COUPLING GUARDS

Coupling guards, Figure 15, of fabricated steel are available for use with coupled reducer input shafts on all sizes. They offer protection to personnel from contacting rotating parts and from objects falling into the rotating coupling.

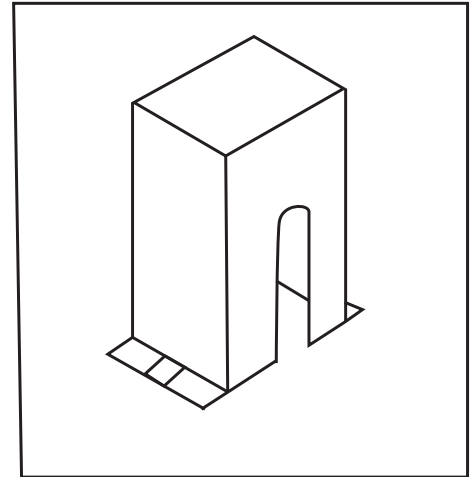

Figure 15 - Coupling Guard

REPLACEMENT OF PARTS

Using tools normally found in a maintenance department, a Dodge Maxum XTR speed reducer can be disassembled and reassembled by a skilled mechanic familiar with the product. Cleanliness is very important to prevent the introduction of dirt into the bearings and other parts of the reducer. A tank of clean solvent, an arbor press, and equipment for heating bearings and gears (for shrinking these parts on shafts) should be available.

The oil seals are contact lip seals. Considerable care should be used during disassembly and reassembly to avoid damage to the surface on which the seals rub. The keyways in the input and output shafts should be covered with tape or paper before disassembly and reassembly. Ensure that any burrs or nicks on surfaces of the input or output shafts are removed prior to disassembly or reassembly.

When ordering replacement parts, specify the reducer size, reducer model number, part name, part number, and quantity. It is strongly recommended that, when a pinion or gear is replaced, the mating pinion or gear is also replaced.

If the large gear on the output shaft must be replaced, it is recommended that an output shaft assembly consisting of a gear assembled on a shaft be ordered to ensure undamaged surfaces on the output shaft where the output seals rub. However, if it is desired to use the old output shaft, press the gear and bearing off and examine the rubbing surface under the oil seal carefully for possible scratching or other damage resulting from the pressing operation. To prevent oil leakage at the shaft oil seals, the smooth surface of the output shaft must not be damaged.

If any parts must be pressed from a shaft or from the output hub, this should be done before ordering parts to make sure that none of the bearings or other parts are damaged in removal. Do not press against the rollers or cage of any bearing. Because old shaft oil seals may be damaged in disassembly, it is advisable to order replacements for these parts.

WARNING: To ensure that drive is not unexpectedly started, turn off and lock out or tag power source before proceeding. Remove all external loads from drive before removing or servicing drive or accessories. Failure to observe these precautions could result in bodily injury.

WARNING: Warranty service or repair must be performed only by Dodge authorized service shops. Failure to adhere to this practice may invalidate warranty.

TROUBLESHOOTING CHART

Trouble	What to Inspect	Action
OVERHEATING	1. Oil cooler (if equipped)	Check coolant and oil flow. If top of the heat exchanger is at a level above the gearbox normal oil level, air can get trapped in the heat exchanger. Loosen piping at the top of the heat exchanger and vent the air out. Oil temperature in the reducer should be about 150° to 165° F (65° to 74°C) when equipped with an oil cooler. Check pipes and cooler/heat exchanger for deposits of sediment.
	2. Oil Level	Check dipstick or sight plug for correct oil level.
	3. Bearings	Check bearing end play and radial clearance. All shafts must turn freely when disconnected from load.
	4. Breather	Breather must be open. Replace if plugged.
	5. Type of oil	Oil viscosity higher than recommended for ambient temperature. Refer to oil selection section and fill with proper viscosity selection.
	6. Oil condition	Change oil.
SHAFT FAILURE	1. Type of coupling	Rigid couplings between rigidly supported shafts can cause shaft failure. Replace with flexible coupling that provides required lateral float.
	2. Coupling alignment	Realign equipment as necessary.
	3. Overhung load	Sprockets or pulleys may be mounted on either the input or output shafts. Ensure proper tension.
	4. Excessive high energy loads	Equip reducer with couplings designed to absorb shock or repetitive shock loads
BEARING FAILURE	1. Overloads	Compare the applied load to the reducer mechanical rating and ensure that appropriate service factor is applied for the application.
	2. Overhung loads	Sprockets or pulleys may be mounted on either the input or output shafts. Ensure proper tension.
	3. Bearing adjustment	Check bearing end play and radial clearance. All shafts must turn freely when disconnected from load.
	4. Bearing lubrication	If equipped, check operation of the lube oil pump. Output pressure at full speed should not be less than 15 psi (1 Bar). Clean or replace filter on pump. Replace worn, cracked or badly heat-discolored bearings.
	5. Rust formation	Seal unit to prevent entrance of moisture and to reduce condensation inside unit. Drain condensation often. Run the unit to full warm frequently during long shutdowns or fill the reducer COMPLETELY with oil.
	6. Storage conditions	Long periods of storage in moist atmospheres will cause destructive rusting of bearings and gears. If this occurs, disassemble the unit, inspect and clean or replace parts.
OIL LEAKAGE	1. Oil level	Add oil or drain excess oil from housing as required. Maintain oil level as indicated by the oil sight plug or dipstick.
	2. Breather	If breather is clogged remove and replace.
	3. Oil Seals	Check oil seals and replace if worn.
	4. Plugs, gauges and fittings	Apply thread sealant and tighten.
	5. Housings and caps	Tighten bolts or cap screws. If leak persists, action depends on leak location. NOTE: In all cases prior to starting work. The oil should be drained below the area being worked on to avoid spillage. If leak is from seal carrier or shaft end cover, replace O-ring on seal carrier or end cover pilot diameter. If leak is from housing joint between centerpiece and end caps, remove housing end cap. Clean mating surfaces. Apply a 1/8" (3 mm) bead of Loctite 515 to the housing flange ensuring that the drain holes are circled. Refill reducer to proper level.
GEAR WEAR	1. Gear tooth wear and failure	Contact factory
	2. Backlash	Nominal range is .014" to .022". Contact factory.
	3. Misalignment	Check contact pattern on gear face. 75% of the total face width is correct.
	4. Overloads	Compare the applied load to the reducer mechanical rating and ensure that appropriate service factor is applied for the application.
	5. Oil Level	Check dipstick or sight plug for correct oil level.
	6. Type of oil	Check oil viscosity against recommendation for ambient temperature and operating speed. Refer to oil selection section and fill with proper viscosity selection.
	7. Coupling lateral float	Rigid couplings between rigidly supported shafts can cause excessive shaft deflection. Replace with flexible coupling that provides required lateral float.
	8. Rust formation	Seal unit to prevent entrance of moisture and to reduce condensation inside unit. Drain condensation often. Run the unit to full warm frequently during long shutdowns or fill the reducer COMPLETELY with oil.
	9. Unusual or Increasing noise	See "GEAR WEAR" and "BEARING FAILURE"
	10. Defective Coupling	Contact coupling vendor
	11. Reducer Foundation	Check for soft foot condition (improper shimming at foot). Tighten fasteners to recommended torques. Replace damaged fasteners.

Dodge Industrial, Inc.
1061 Holland Road
Simpsonville, SC 29681
+1 864 297 4800

