

Instruction Manual for No. 18D DODGE FLEXIDYNE® Drive

These instructions must be read thoroughly before installing or operating this product.

WARNING: To ensure that drive is not unexpectedly started, turn off and lock out or tag power source before proceeding. Failure to observe these precautions could result in bodily injury.

WARNING: The user is responsible for conforming with the National Electrical Code and all other applicable local codes, wiring practices, grounding, disconnects and overcurrent protection are of particular importance. Failure to observe these precautions could result in severe bodily injury or loss of life.

DESCRIPTION:

FLEXIDYNE dry fluid couplings are a unique concept to provide soft start and momentary overload protection for all types of driven equipment. Standard NEMA-B motors with RPM base speeds of either 1160 or 860 are commonly used with a FLEXIDYNE drive, yet other available power sources may be used with the FLEXIDYNE drive.

The dry "fluid" in the FLEXIDYNE drive is heat-treated steel shot. A measured amount of the steel shot, referred to as flow charge, is added into a housing which has been keyed to the motor shaft. When the motor is started, centrifugal force throws the flow charge to the perimeter of the housing, packs it between the housing and the rotor, which in turn transmits torque to the load.

After the starting period of slippage between housing and rotor, the two become locked together and achieve full load speed, operating without slip.

Consequently, the motor accelerates instantly to base speed, while the load starts gradually and smoothly.

WARNING: Because of the possible danger to persons(s) or property from accidents which may result from the improper use of products, it is important that correct procedures be followed. Products must be used in accordance with the engineering information specified in the catalog. Proper installation, maintenance and operation procedures must be observed. The instructions in the instruction manuals must be followed. Inspections should be made as necessary to assure safe operation under prevailing conditions. Proper guards and other suitable safety devices or procedures as may be desirable or as may be specified in safety codes should be provided, and are neither provided by Dodge nor are the responsibility of Dodge. This unit and its associated equipment must be installed, adjusted and maintained by qualified personnel who are familiar with the construction and operation of all equipment in the system and the potential hazards involved. When risk to persons or property may be involved, a holding device must be an integral part of the driven equipment beyond the speed reducer output shaft.

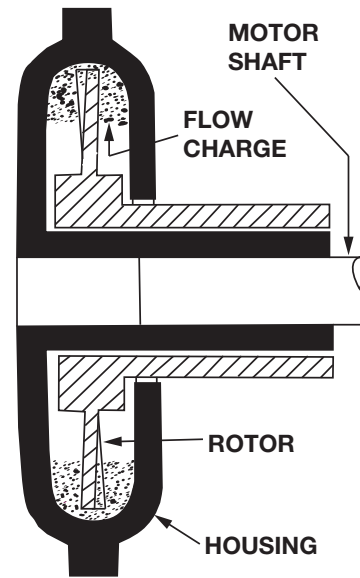

Figure 1 - Housing Cross Section

INSTALLATION

Install the sheave on the driven hub. Use screws and lockwashers provided with the sheave. Torque screws to 160 inch pounds.

Slide the FLEXIDYNE drive on the motor shaft with collar as close to motor as possible. Tighten key setscrew securely against motor shaft key. Tighten shaft setscrew against motor shaft. Note that drive hub must be installed on the motor shaft (or on other installations it must be the first part of the FLEXIDYNE drive to receive power from the power source) to permit proper operation of the FLEXIDYNE drive.

START-UP

1. Remove one of the filler plugs and install 1/2 of the amount of flow charge specified in Table 1. Replace and tighten filler plug, making sure that no flow charge is trapped in the threads. Remove other filler plug and install the remaining 1/2 of the specified amount of flow charge repeating the same procedure. Tighten filler plugs to recommended torque of 700 inch-lbs.
2. Attach AC ammeter (conventional clamp-on or equivalent) to one line of the AC motor. Set range to cover 200% of motor nameplate current.
3. Note maximum allowable acceleration time for FLEXIDYNE drive as stated in Tables 1 and 2. Note: Table 2 lists starting time capacity for various starting cycles.
4. Push start button. Observe motor current during load acceleration and number of seconds required to reach full speed (Fig. 2).



Increase amount of flow charge if:

- A. Acceleration time reaches maximum allowable before load is up to speed. Turn off power immediately if this time is reached.
- B. Acceleration amperage is below motor nameplate.

Decrease amount of flow charge if:

- A. Acceleration time is less than 1-1/2 seconds.
- B. Acceleration amperage is above 200% of motor nameplate.

The amount of flow charge in the FLEXIDYNE drive determines the acceleration time for a given load. Slower acceleration times will occur when less flow charge is used and, faster acceleration, from stop to full speed, will be observed with greater amounts of flow charge.

CAUTION: The FLEXIDYNE drive motor must slip during acceleration to allow flow charge to become evenly distributed in the FLEXIDYNE drive housing. Therefore, DO NOT ALLOW FLEXIDYNE MECHANISM TO RUN "FREE" (that is, without a load on the driven end), otherwise, an out-of-balance condition may result, damaging mechanism.

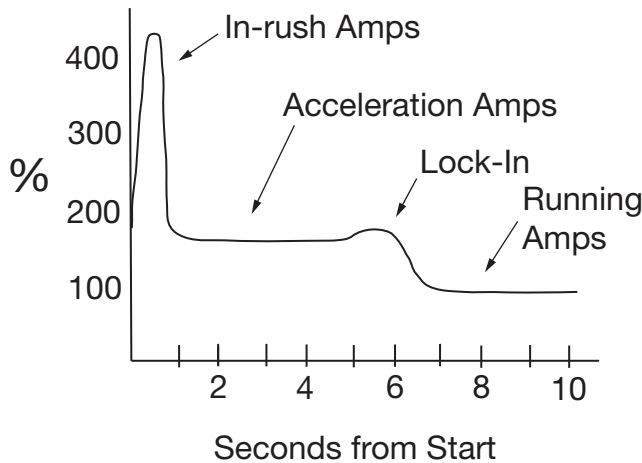

Figure 2 - Flow Charge Graph

OPERATION

The FLEXIDYNE drive should start the load smoothly and without delay provided the proper amount of flow charge has been used. Should the acceleration time exceed the maximum allowable in Table 1, shut off power to the FLEXIDYNE drive immediately. Allow the FLEXIDYNE drive to cool, then add small amounts of flow charge until proper acceleration is observed.

Vibration is an indication of accelerating too rapidly and not allowing flow charge to become evenly distributed in the FLEXIDYNE drive housing. This can be corrected by removing small amounts of flow charge until vibration subsides. Other causes of vibration are undersized shafting, unit not installed far enough on shaft, or worn bore in the unit.

Slippage - The FLEXIDYNE drive can, without slipping, transmit overloads 30% above its pre-set starting torque. Should this breakaway torque be exceeded, the FLEXIDYNE drive will slip and generate heat. Although slippage usually indicates increased loads, it can also be caused by worn flow charge or a worn rotor, especially if the FLEXIDYNE drive has been in operation for some time. The necessity to replace either a rotor or flow charge will be made evident by a loss in power transmitting capacity of the FLEXIDYNE drive.

MAINTENANCE

For average industrial applications involving 3 or 4 starts a day of not more than 6 seconds acceleration time each, the flow charge should be changed every 10,000 hours of operation. For more severe conditions, visually inspect flow charge at more frequent intervals; it should be changed when it has deteriorated to a half powder, half granular condition. Visual inspections should continue until enough flow charge changes have been made to adequately establish a schedule for renewing FLEXIDYNE drive flow charge.

The FLEXIDYNE drive has been lubricated at the factory. The ball bearing requires no further lubrication. The needle bearing, however, should be lubricated per the following schedule:

$$\frac{500}{\text{Starts per day}} = \text{Number of days between greasing}$$

One-half to one ounce of any good grade high temperature roller bearing grease should be used. Never apply grease, oil or any other foreign material to the flow charge.

THERMAL CAPACITY

Since there is slippage within the flow charge during acceleration, heat is generated from friction. The thermal capacity of the FLEXIDYNE drive is based on balancing this heat generated during acceleration against the cooling time between accelerations. The amount of heat generated is determined by the amount of horsepower dissipated by slipping and the duration of each acceleration. If the flow charge weight is light, the heat generated will not be as great as that which would be generated with a heavier flow charge when compared at the same acceleration time. A longer time between starts will dissipate more heat; therefore, higher starting horsepowers may be transmitted, or longer acceleration times may be allowable. (See Starting Cycle)

Acceleration times shown in Table 1 are for starting frequencies of one start per hour or less. If starting frequency is other than once every two hours, use acceleration time for actual starting cycle shown in Table 2.

Acceleration times listed in Tables 1 and 2 are the MAXIMUM permissible for the various starting frequencies listed. The MINIMUM acceleration time required for proper FLEXIDYNE drive operation is 1 to 1-1/2 seconds. This is the time required for the flow charge to be uniformly distributed around the housing cavity before the unit "locks in." Any acceleration time between the minimum and maximum listed is acceptable, although a shorter acceleration time will generally provide longer wear life. For applications requiring a specific acceleration time (within these limits) flow charge may be added or removed to produce the required results.

Stalled - If a jam-up stalls the drive, the motor continues to run and the FLEXIDYNE drive slips. This causes heat to be generated at twice the rate of normal acceleration. Therefore, the allowable slipping time, when stalled, is half the allowable acceleration time given in Table 1.

Starting Cycle is the time from the beginning of one acceleration to the beginning of the next. Allowable acceleration times in Table 2 are based on the assumption that the FLEXIDYNE drive will be running continuously except for a momentary stop before the next start. If the stop is more than momentary, decrease the actual starting cycle by one-half the stopped time before using

Table 2; for example, with a 50 minute actual starting cycle of which 20 minutes is stopped time, decrease 50 by half of 20 to give 40 minutes as the starting cycle time to use for Table 2.

Grouped Starts - For several starts grouped together followed by uninterrupted running, add the acceleration times of all starts and consider it as the time for one start. The starting cycle would be the time from the beginning of one group of starts to the beginning of the next group.

REPLACEMENT OF PARTS

DISASSEMBLY:

1. Loosen set screws (48, 50) in collar (46) and remove FLEXIDYNE drive from motor shaft. Remove sheave driven hub.
2. Remove filler plug (37, 38) and drain flow charge from FLEXIDYNE housing (32, 30).
3. Remove housing screws (35, 36) and housing cover (32). Remove cover seal retainer by inserting a small pin in the holes for the drive screws and tapping on the pin to remove drive screws. Remove cover seal (33).
4. Remove the four drive hub screws (42) and remove the drive housing (30). Remove housing seal (64).
5. Remove seal felt (80) from driven hub. Remove rotor retainer (58) and rotor (56).
6. Remove collar (46) and slide driven hub (70) off drive hub (24).
7. Remove needle bearing inner race retaining ring (88) and remove needle bearing inner race (86). Remove ball bearing snap ring and remove ball bearing (74).
8. Remove needle bearing seal (90) and needle bearing retaining ring (92). Remove needle bearing (84) by placing a plug in the right-hand end (as viewed in the drawing) of the driven hub and press on plug.

REASSEMBLY:

1. Press needle bearing (84) into driven hub. Needle bearing should be completely filled with high temperature roller bearing grease. Install needle bearing retaining ring (92).
2. Press ball bearing (74) onto drive hub (24) pressing against inner (not outer) race of ball bearing. Install ball bearing snap ring (76).
3. Install needle bearing inner race (86) on drive hub (24). Install needle bearing inner race retaining ring (88).
4. Slide drive hub (24) into driven hub (70). Press against bearing (74) not drive hub (24).
5. Tap needle bearing seal (40) into place and install motor shaft collar (46). Place rotor (56) and rotor retainer (58) in position on driven hub (70). Install and tighten rotor screws (62). Install seal felt (80).
6. Stand FLEXIDYNE drive on collar end and place housing seal (64) (red in color) in position on rotor retainer (58).
7. Using dowel pins (44) as guides place drive housing (30) in position and tap gently until housing starts to pass over housing seal (64). The seal (64) may tend to cock. A wire or other blunt probe may be used to push outer corner of seal (64) into position in drive housing (30). Rotating the driven hub (70) may also help to position the seal properly. When seal (64) is properly positioned tap drive housing (30) into place. Install and tighten the four drive hub screws to 110 ft. lbs. (42).
8. Install cover seal (33) (gray in color) in drive housing cover. Align holes in seal retainer with holes in housing cover and install drive screws.
9. Place cover (32) in position on drive housing (30) so that filler plugs (37) are diametrically opposed. Install and tighten housing screws.
10. Install one filler plug (37, 38). Tighten to recommended torque of 700 in.-lbs.
11. Install flow charge in amount determined by Table 1. Install remaining filler plug (37, 38). Tighten to recommended torque of 700 in.-lbs.
12. Replace sheave and torque to 160 in.-lbs. Install unit on motor shaft. Tighten setscrews (48, 50) in collar (46).

Table 1 - Flow Charge Recommendations

Based on % Starting Torque for 1175 RPM NEMA Design B Motors

Rated Motor HP	100% @ 1175 RPM				125% @ 1160 RPM				150% @ 1150 RPM				175% @ 1130 RPM				200% @ 1100 RPM			
	Starting HP	Flow Charge		Max Time in Secs.	Starting HP	Flow Charge		Max Time in Secs.	Starting HP	Flow Charge		Max Time in Secs.	Starting HP	Flow Charge		Max Time in Secs.	Starting HP	Flow Charge		Max Time in Secs.
		Lbs	Oz			Lbs	Oz			Lbs	Oz			Lbs	Oz			Lbs	Oz	
50	50	62	74	85	94	15	11	64
60	60	75	89	102	17	4	69	113	19	6	53
75	75	93	111	17	10	55	127	19	10	45	141	21	14	38
100	100	15	12	60	124	18	7	47	148	20	9	36	170	22	13	30	189	24	13	26
125	125	18	7	47	155	21	1	35	185	23	3	28	212	25	3	23	236	27	3	20
150	150	20	5	35	186	22	15	26	222	25	0	22	254	27	0	19	283	29	4	16

Based on % Starting Torque for 875 RPM NEMA Design B Motors

Rated Motor HP	100% @ 875 RPM				125% @ 870 RPM				150% @ 850 RPM				175% @ 840 RPM				200% @ 820 RPM			
	Starting HP	Flow Charge		Max Time in Secs.	Starting HP	Flow Charge		Max Time in Secs.	Starting HP	Flow Charge		Max Time in Secs.	Starting HP	Flow Charge		Max Time in Secs.	Starting HP	Flow Charge		Max Time in Secs.
		Lbs	Oz			Lbs	Oz			Lbs	Oz			Lbs	Oz			Lbs	Oz	
40	40	15	3	200	50	18	0	180	58	20	6	164	67	22	8	146	75	24	7	130
50	50	17	14	180	62	20	4	156	73	22	14	134	84	24	14	115	94	26	14	103
60	60	19	13	160	75	22	6	130	87	24	15	112	101	26	1	95	112	28	12	82

Maximum allowable acceleration time for one start per hour, or less. Proper application of the FLEXIDYNE mechanism requires that the load be connected. Without connected load acceleration time may be too fast to allow charge to be distributed for proper balance.

Table 2 - Thermal Capacity FLEXIDYNE Drive

Single Cavity FLEXIDYNE Drive Size	Starting HP ①	Maximum Allowable Acceleration Time in Seconds for Standard Motor Speeds at Various Starting Cycles																	
		2 Hours		1 Hour		30 Min.		15 Min.		10 Min.		5 Min.		2 Min.		1 Min.			
		720	870	1160	720	870	1160	720	870	1160	720	870	1160	720	870	1160	720	870	1160
18	20	600	560
	40	370	200	...	350
	60	220	160	...	200
	80	160	120	...	150
	100	...	96	60	...	60
	120	...	72	49	...	49
	140	38	...	38
	160	33	...	33
	180	28	...	28
	200	25	...	25
220	22	...	22	
240	20	...	20	
260	18	...	18	
280	16	...	16	
300	14	...	14	

① Starting HP is determined by amount of flow charge installed, see Table 1.

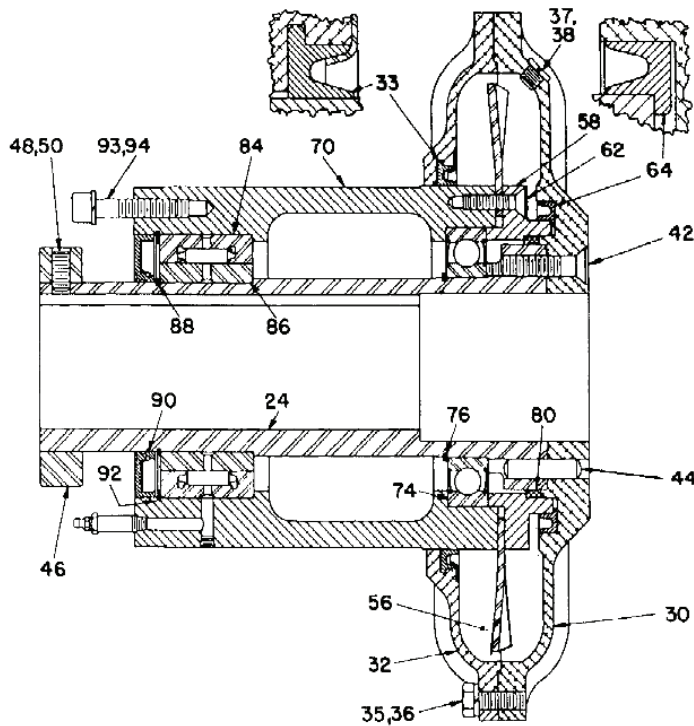

Replacement Parts for No. 18D FLEXIDYNE Drive

Reference	Name of Part	Number Required	Part Number
24, 30, 42, 44	① Drive Hub and Housing Assembly	1	2-7/8" Bore 3-3/8" Bore 391236 391239
32	Housing cover and Seal Assembly ②	1	391247
33	③ Housing Cover	1	318003
	③ Cover Seal (Gray Color) with Retainer and Drive Screws	1	391257
35	Housing Screw	6	411102
36	Lockwasher	6	419013
37 ⑤	Filler Plug (Hex Head)	2	315021
38	Lockwasher	2	419123
42 ④	Drive Hub Screw	4	415080
46	Motor Shaft Collar	1	318020
48	Key Set Screw	2-7/8" Bore 3-3/8" Bore	1 1 400158 400154
50	Shaft Set Screw	2-7/8" Bore 3-3/8" Bore	1 1 400162 400158

Reference	Name of Part	Number Required	Part Number
56	Rotor	1	318006
58	Rotor Retainer	1	318007
62	Rotor Screw	6	415070
64	Housing Seal (Red Color)	1	318038
70	Driven Hub	1	318005
74	Ball Bearing	1	391238
76	Ball Bearing Inner Snap Ring	1	421037
80	Seal Felt	1	318024
84	Needle Bearing	1	426029
86	Needle Bearing Inner Race	1	426038
88	Needle Bearing Inner Race Retaining Ring	1	421035
90	Needle Bearing Seal	1	318025
92	Needle Bearing Retaining Ring	1	421042
93	Sheave Screw	6	417184
94	Lockwasher	6	419013

① Drive Hub 24 and Drive Housing 30 are fitted and must be ordered together.

② Includes parts listed immediately below.

③ Parts listed make up the assemblies under which they are listed.

④ Included in Drive Hub and Housing Assembly

⑤ When replacing a filler plug with a screwdriver slot head, order Filler Plug #322219 and Lockwasher #419114. Hex head filler plugs are not interchangeable with slotted head filler plugs.

Note: Order parts giving the 6 digit part number - not the 2 digit reference number.

FLEXIDYNE Mechanism Trouble Analysis		
Symptom	Cause	Cure
Vibration	<ol style="list-style-type: none"> 1. Misalignment 2. Bent shaft 3. Excess flow charge 4. Fused flow charge 5. Improper installation – Output shaft jammed against housing 	<ol style="list-style-type: none"> 1. Realign drive or coupling. 2. Replace or straighten. 3. Remove small amount of flow charge. 4. Correct the overload. 5. Readjust spacing between shafts and FLEXIDYNE housing.
Erratic Acceleration	<ol style="list-style-type: none"> 1. Breakdown of flow charge 2. Caked flow charge 3. Below minimum amount of flow charge 	<ol style="list-style-type: none"> 1. Replace flow charge. 2. Moist environment – use stainless flow charge. 3. Add flow charge.
FLEXIDYNE Mechanism Doesn't Slip	<ol style="list-style-type: none"> 1. Improper installation – Output shaft jammed against housing 2. Flow charge in bearings – causing bearing seizure 	<ol style="list-style-type: none"> 1. Readjust spacing between shafts and FLEXIDYNE housing. 2. Replace seals, bearings and flow charge or replace FLEXIDYNE mechanism.
Excessive Slippage	<ol style="list-style-type: none"> 1. Not enough flow charge 2. Overload 3. Worn flow charge 4. Worn rotor 	<ol style="list-style-type: none"> 1. Add flow charge. 2. Relieve overload 3. Replace flow charge. 4. Replace rotor.
Poor or short flow charge life	<ol style="list-style-type: none"> 1. Excessive slip at start up 2. Excessive inching or jogging of machine 	<ol style="list-style-type: none"> 1. Add flow charge to reduce starting time. 2. Install time delay in motor control circuit.

FLEXIDYNE Mechanism Flow Charge Analysis	
Condition	Cause
<ol style="list-style-type: none"> 1. Red oxide color, granular consistency 2. Red oxide color, powdery consistency, possibly with powdery flakes 3. Black, powdery 4. Red oxide, powdery and chunky 5. Clumping of flow charge 	<ol style="list-style-type: none"> 1. Normal after some usage. 2. Worn-out, can cause FLEXIDYNE mechanism damage. 3. Rotor worn, excessive slip and heat. 4. Worn-out and moisture present. 5. Moisture present, use stainless flow charge.

Dodge Industrial, Inc.
1061 Holland Road
Simpsonville, SC 29681
+1 864 297 4800

