



Motorized Torque-Arm® II Speed Reducers MTA2-MTA8 C-Faced Coupled Instruction Manual

These instructions must be read thoroughly before installation or operation. This instruction manual was accurate at the time of printing. Please see dodgeindustrial.com for updated instruction manuals.

WARNING: To ensure the drive is not unexpectedly started, turn off and lock-out or tag power source before proceeding. Failure to observe these precautions could result in bodily injury.

WARNING: All products over 25 kg (55 lbs) are noted on the shipping package. Proper lifting practices are required for these products.

NOTE: This reducer is compatible with the Dodge® Smart Sensor, that can be installed in the adapter plug labeled "smart sensor." The plug and sensor can be moved to different locations as required by mounting position.

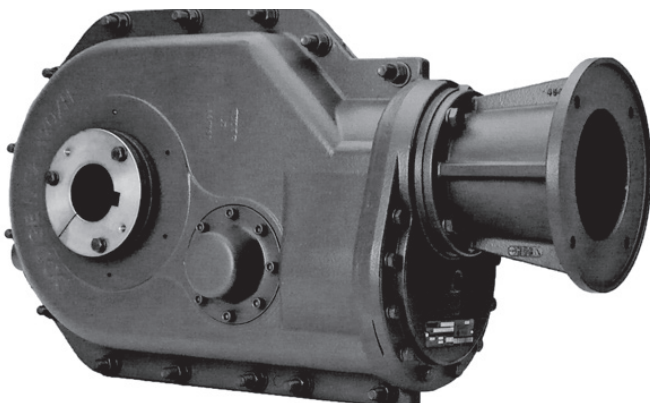

INSTALLATION OF MOTOR ADAPTER & 3-PC COUPLING (NEMA 56C–250TC, IEC 90–180)

1. Use lifting bracket to lift reducer onto work table and secure reducer to prevent movement.
2. Inspect coupling components and remove any protective coatings/lubricants from bores, mating surfaces, and fasteners.
3. Install the reducer hub with key so that the main body of the hub is flush with the end of the reducer shaft, and tighten set screw(s) using Table 1a/1b. Please note that some sizes utilize two set screws to hold the hub to the shaft.

Table 1a: Coupling Set Screw Tightening Torque - NEMA (lb-in)

Motor Adapter	Reducer Case Size						
	2115H	3203H	4207H	5215H	6307H	7315H	8407H
56C	225	-	-	-	-	-	-
140TC	225	-	-	-	-	-	-
180TC	225	225	260	260	260	260	260
210TC	225	225	260	260	260	260	260
250TC	225	225	260	260	260	260	260
280TSC	-	225	260	260	260	260	260
280TC	-	225	260	260	260	260	260
320TSC	-	-	260	260	260	260	260
320TC	-	-	540	540	540	540	540
360TSC	-	-	-	260	260	260	260
360TC	-	-	-	540	540	540	540
405TSC	-	-	-	-	-	540	540
405TC	-	-	-	-	-	540	540

WARNING: Because of the possible danger to person(s) or property from accidents which may result from the improper use of products, it is important that correct procedures be followed. Products must be used in accordance with the engineering information specified in the catalog. Proper installation, maintenance and operation procedures must be observed. The instructions in the instruction manuals must be followed. Inspections should be made as necessary to assure safe operation under prevailing conditions. Proper guards and other suitable safety devices or procedures as may be desirable or as may be specified in safety codes should be provided, and are neither provided by Dodge nor are the responsibility of Dodge. This unit and its associated equipment must be installed, adjusted and maintained by qualified personnel who are familiar with the construction and operation of all equipment in the system and the potential hazards involved. When risk to persons or property may be involved, a holding device must be an integral part of the driven equipment beyond the speed reducer output shaft.

Table 1b: Coupling Set Screw Tightening Torque - IEC (Nm)

Motor Adapter	Reducer Case Size						
	2115H	3203H	4207H	5215H	6307H	7315H	8407H
90	25	-	-	-	-	-	-
100	25	25	29	29	-	-	-
112	25	25	29	29	-	-	-
132	25	25	29	29	29	29	-
160	25	25	29	29	29	29	29
180	-	-	29	29	29	29	29
200	-	-	61	61	61	61	61
225	-	-	-	61	61	61	61
225S	-	-	-	61	61	61	61
250	-	-	-	-	-	31	31
250S	-	-	-	-	-	31	31
280	-	-	-	-	-	31	31
280S	-	-	-	-	-	31	31

- Inspect motor adapter and reducer to ensure that are no burrs or debris present on the contact surfaces of each part.
 - Position motor adapter onto reducer and secure using the supplied hardware.
- NOTE: NEMA 56C–250TC and IEC 90–180 motor adapters attach to the reducer using four bolts and four lock-washers.**
- Torque motor adapter to reducer bolts per Table 2a.

Table 2a: Motor Adapter to Reducer Tightening Torque - NEMA

Motor Adapter	Fastener Size	Bolt Tightening Torque
56C	1/2-13	75 - 70 lb-ft (102 - 95 Nm)
140TC	1/2-13	75 - 70 lb-ft (102 - 95 Nm)
180TC	1/2-13	75 - 70 lb-ft (102 - 95 Nm)
210TC	1/2-13	75 - 70 lb-ft (102 - 95 Nm)
250TC	1/2-13	75 - 70 lb-ft (102 - 95 Nm)
280TC/280TSC	1/2-13	75 - 70 lb-ft (102 - 95 Nm)
320TC/320TSC	1/2-13	75 - 70 lb-ft (102 - 95 Nm)
360TC/360TSC	1/2-13	75 - 70 lb-ft (102 - 95 Nm)
405TC/405TSC	1/2-13	75 - 70 lb-ft (102 - 95 Nm)

Table 2b: Motor Adapter to Reducer Tightening Torque - IEC

Motor Adapter	Fastener Size	Bolt Tightening Torque
90	1/2-13	75 - 70 lb-ft (102 - 95 Nm)
100	1/2-13	75 - 70 lb-ft (102 - 95 Nm)
112	1/2-13	75 - 70 lb-ft (102 - 95 Nm)
132	1/2-13	75 - 70 lb-ft (102 - 95 Nm)
160	1/2-13	75 - 70 lb-ft (102 - 95 Nm)
180	1/2-13	75 - 70 lb-ft (102 - 95 Nm)
200	1/2-13	75 - 70 lb-ft (102 - 95 Nm)
225	1/2-13	75 - 70 lb-ft (102 - 95 Nm)
225S	1/2-13	75 - 70 lb-ft (102 - 95 Nm)
250	5/8-11	115 - 110 lb-ft (156 - 149 Nm)
250S	5/8-11	115 - 110 lb-ft (156 - 149 Nm)
280	5/8-11	115 - 110 lb-ft (156 - 149 Nm)
280S	5/8-11	115 - 110 lb-ft (156 - 149 Nm)

- Install the motor hub with key so that the main body of the hub is flush with the end of the motor shaft. Do not tighten set screw(s).
- Insert elastomeric center element into the reducer coupling hub.
- Lift the motor using lift-assist equipment and align the jaws of both coupling hubs so that they will interlock when the motor is installed.
- Install the motor by aligning motor tenon and reducer tenon and sliding the motor forward until it stops against the reducer flange.
- Install and tighten the motor bolts. Torque motor bolts per Table 3a/3b.

Table 3a: Motor Bolt Tightening Torque - NEMA

NEMA Motor Frame	Motor Bolt	Bolt Tightening Torque
56C-140TC	3/8-16	26 - 23 lb-ft (36 - 31 Nm)
180TC	1/2-13	75 - 70 lb-ft (102 - 95 Nm)
210TC	1/2-13	75 - 70 lb-ft (102 - 95 Nm)
250TC	1/2-13	75 - 70 lb-ft (102 - 95 Nm)
280TC/280TSC	1/2-13	75 - 70 lb-ft (102 - 95 Nm)
320TC/320TSC	5/8-11	115 - 110 lb-ft (156 - 149 Nm)
360TC/360TSC	5/8-11	115 - 110 lb-ft (156 - 149 Nm)
405TC/405TSC	5/8-11	115 - 110 lb-ft (156 - 149 Nm)

Table 3b: Motor Bolt Tightening Torque - IEC

IEC Motor Frame	Motor Bolt	Bolt Tightening Torque
90	M10	39 - 36 lb-ft (53 - 50 Nm)
100	M12	68 - 65 lb-ft (92 - 90 Nm)
112	M12	68 - 65 lb-ft (92 - 90 Nm)
132	M12	68 - 65 lb-ft (92 - 90 Nm)
160	M16	158 - 155 lb-ft (214 - 210 Nm)
180	M16	158 - 155 lb-ft (214 - 210 Nm)
200	M16	158 - 155 lb-ft (214 - 210 Nm)
225	M16	158 - 155 lb-ft (214 - 210 Nm)
225S	M16	158 - 155 lb-ft (214 - 210 Nm)
250	M16	158 - 155 lb-ft (214 - 210 Nm)
250S	M16	158 - 155 lb-ft (214 - 210 Nm)
280	M16	158 - 155 lb-ft (214 - 210 Nm)
280S	M16	158 - 155 lb-ft (214 - 210 Nm)

- Look through the access hole on the motor adapter and verify that the coupling faces are in full contact with the elastomeric element—without any preload on the element.
- Tighten the motor half set screw. Torque set screw(s) per Table 1a/1b.
- Install the access hole plug(s) into motor adapter.

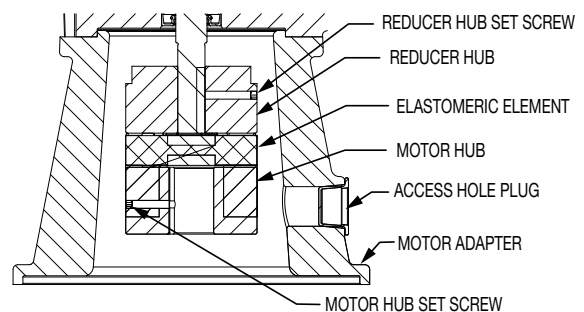

Figure 1 - Motor/Reducer Coupling Assembly

INSTALLATION OF MOTOR ADAPTER AND 3-PC COUPLING (NEMA 280TC–405TC, IEC 200–280)

1. Use lifting bracket to lift reducer onto work table and secure reducer to prevent movement.
2. Inspect motor adapter and reducer to ensure that there are no burrs or debris present on the contact surfaces of each part.
3. Position motor adapter onto reducer and secure using the supplied hardware.

NOTE: The NEMA 280TC motor adapter attaches to the reducer using four bolts and four lock-washers, and NEMA 320TC–405TC and IEC 200–280 motor adapters attach to the reducer using eight bolts and eight lockwashers.

4. Torque motor adapter to reducer bolts per Table 2a and Table 2b.
5. Inspect coupling components and remove any protective coatings/lubricants from bores, mating surfaces, and fasteners.
6. Install the reducer hub with key so that the main body of the hub is flush with the end of the reducer shaft, and tighten set screw(s) using Table 1a and Table 1b. Please note that some sizes utilize two set screws to hold the hub to the shaft.
7. Install the motor hub with key so that the main body of the hub is flush with the end of the motor shaft. Do not tighten set screw(s).
8. Insert elastomeric center element into the reducer hub.
9. Lift the motor using lift-assist equipment and align the jaws of both coupling hubs so that they will interlock when the motor is installed.
10. Install the motor by aligning motor tenon and reducer tenon and sliding the motor forward until it stops against the reducer flange.
11. Install and tighten the motor bolts. Torque motor bolts per Table 3a and Table 3b.
12. Look through the access hole on the motor adapter and verify that the coupling faces are in full contact with the elastomeric element—without any preload on the element.
13. Tighten the motor half set screw(s). Torque set screw(s) per Table 1a and Table 1b.
14. Install the access hole plug(s) into motor adapter.

INSTALLATION

1. Use lifting bracket to lift reducer.
2. Determine the running positions of the reducer. Although the reducer may be operated in any position, the preferred mounting position is with the motor in the horizontal position (Position C) as shown in Figure 2. Position B is not recommended. Note that the reducer is supplied with seven plugs: four around the sides for horizontal installations, two plugs on the front face, and one plug on the back face for vertical installations. These plugs must be arranged relative to the running positions as follows:

Horizontal Installations—Due to the many positions the MTA reducer may be oriented, the factory installed positions of the magnetic plug and breather may need to be relocated. The proper location for the magnetic plug is the hole closest to the bottom of the reducer. The filter breather is to be installed in the upper most hole. Of the two remaining plugs on the sides of the reducer, the highest plug is the minimum oil level plug as shown in Figure 2.

Vertical Installations—Install the filter breather plug in the hole provided in the upper face of the reducer housing. If space is restricted, the breather should be installed in the highest hole on the side of the reducer. Install a non-magnetic plug in the hole in the bottom face of the reducer. Do not install the magnetic plug in the bottom face. The magnetic plug should be located in the lowest level side hole. The highest level side plug is to be the minimum oil level plug.

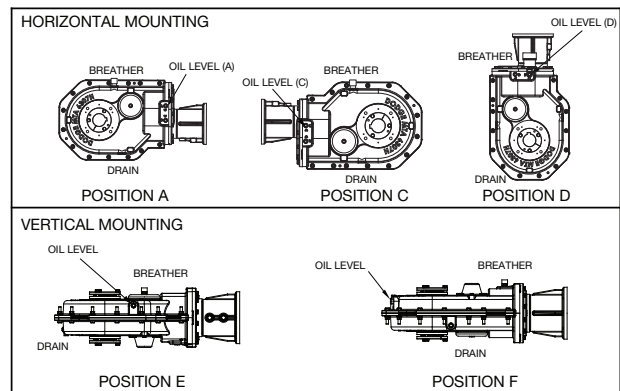

Figure 2 - Mounting Positions, C-Face

Table 4: Approximate Oil Volumes

Case Size	Oil Volume in Quarts ①②③④⑤⑥						Oil Volume in Liters ①②③④⑤⑥					
	Horizontal				Vertical		Horizontal				Vertical	
	A	B	C	D	E (Up)	F (Down)	A	B	C	D	E (Up)	F (Down)
MTA2115H	4-1/4	⑤	3-5/8	7	5-3/8	5-5/8	3-3/4	⑤	3-1/2	6-5/8	5	5-3/8
MTA3203H	6-3/8	⑤	4-3/8	9-3/4	7-3/8	7-5/8	6	⑤	4-1/8	9-1/4	7	7-1/8
MTA4207H	8-1/4	⑤	6-3/4	13-1/8	9-1/4	9-5/8	7-7/8	⑤	6-3/8	12-3/8	8-7/8	9-1/8
MTA5215H	14	⑤	10-1/8	21	16	16-7/8	13-1/4	⑤	9-5/8	20	15-1/8	16
MTA6307H	18-3/8	⑤	15-3/8	30-1/8	23-1/2	24-7/8	17-3/8	⑤	14-1/2	28-1/2	22-1/4	23-1/2
MTA7315H	25	⑤	19-5/8	38-1/4	23-1/4	26-1/2	23-5/8	⑤	18-1/2	36-1/2	22	25-1/8
MTA8407H	29-1/8	⑤	22-5/8	52	31-3/4	31-3/4	27-5/8	⑤	21-3/8	49-1/4	30	30

① Refer to Figure 2 for mounting positions.

② Oil quantity is approximate. Service with lubricant until oil runs out of oil level hole as indicated per drawings in Figure 2.

③ US measure: 1 quart = 32 fluid ounces = .94646 liters

④ Below 15 RPM output speed, oil level must be adjusted to reach the highest oil level plug. If reducer position is to vary from those shown in Figure 1, either more or less oil may be required. Consult Dodge.

⑤ Position B not shown OR recommended, check with factory.

⑥ Position D breather kit (Part Number 472300) configuration should be used for best lubrication and oil level results.

ACCESSORY DODGE MOTORIZED TORQUE-ARM II POSITION D BREATHER KIT (PART NUMBER 472300) FOR MTA2–MTA3 AND MTA4–MTA8

NOTE: This kit should only be used when mounting a Motorized Torque-Arm in position D.

1. Assemble position D breather kit as shown in Figure 3 (MTA2–MTA3) or Figure 4 (MTA4–MTA8).

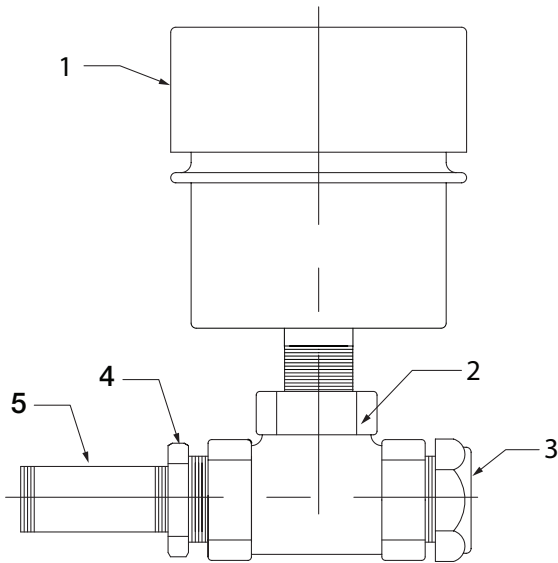

Figure 3 - Position D Breather Kit (MTA2–MTA3)

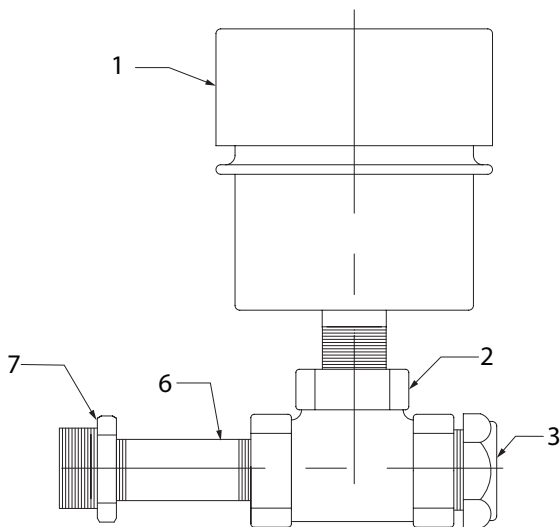

Figure 4 - Position D Breather Kit (MTA4–MTA8)

2. Replace top oil plug on reducer with assembled position D breather kit.
3. Remove standard breather from reducer (if installed) and replace with solid oil plug (see Figure 5).

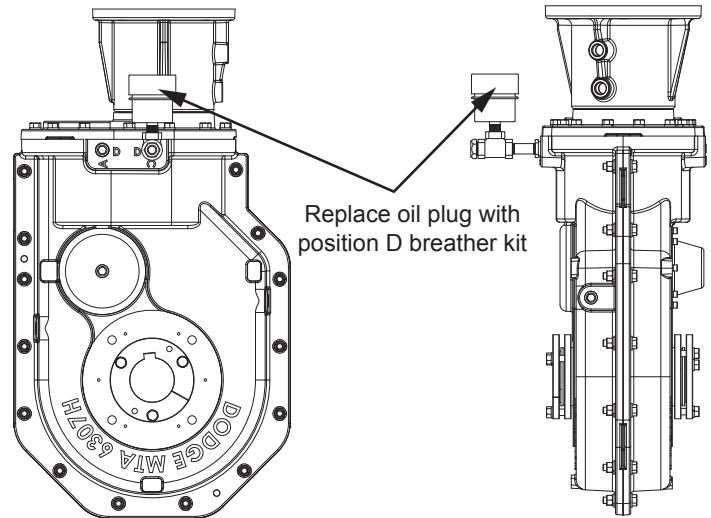

Figure 5 - Installing Position D Breather Kit

Table 1: Parts for Position D Breather Kit

Ref. Number ①	Part Descriptions	Part Number	Quantity	
			MTA2-3	MTA4-8
	Position D Breather Kit	472300	–	–
② 1	Expansion Chamber	240053	1	1
② 2	1/2 Pipe Tee	034720004AB	1	1
② 3	Oil Sight Gauge	430121		
② 4 ③	1/2 x 3/8 Hex Bushing	034600006AB	1	–
② 5	Pipe Nipple 1/2 x 3	034530024DB	1	1
② 6	Pipe Nipple 3/8 x 3	034530024CB	1	1
② 7 ④	3/4 x 1/2 Hex Bushing	034600010AB	–	1

- ① Refer to Figure 3 or Figure 4
- ② Makes up assembly under which it is listed
- ③ This part is used only on MTA 2–MTA 3
- ④ This part is used only on MTA 4–MTA 8

The running position of the reducer in a horizontal application is not limited to the three positions shown in Figure 2. However, if running position is over 20° in position D or over 5° in position A and C—either way from sketches—the oil level plug cannot be used safely to check the oil level unless during the checking, the torque arm is disconnected and the reducer is swung to within 20° for position D or within 5° for position A and C of the positions shown in Figure 2. Because of the many possible positions of the reducer, it may be necessary or desirable to make special adaptations using the lubrication filling holes furnished along with other standard pipe fittings, stand pipes and oil level gauges as required.

Table 5: Oil Recommendations

Output RPM	Torque-Arm II Reducer Size						
	MTA2115H	MTA3203H	MTA4207H	MTA5215H	MTA6307H	MTA7315H	MTA8407H
151–200	320	220	220	220	220	220	220
126–150	320	220	220	220	220	220	220
101–125	320	320	220	220	220	220	220
81–100	320	320	320	220	220	220	220
41–80	320	320	320	220	220	220	220
11–40	320	320	320	320	320	320	320
1–10	320	320	320	320	320	320	320

ISO Grades For Ambient Temperatures of 15°F to 60°F (-9°C to 16°C)							
Output RPM	Torque-Arm II Reducer Size						
	MTA2115H	MTA3203H	MTA4207H	MTA5215H	MTA6307H	MTA7315H	MTA8407H
151–200	220	150	150	150	150	150	150
126–150	220	150	150	150	150	150	150
101–125	220	220	150	150	150	150	150
81–100	220	220	220	150	150	150	150
41–80	220	220	220	150	150	150	150
11–40	220	220	220	220	220	220	220
1–10	220	220	220	220	220	220	220

Notes:

1. Assumes auxiliary cooling where recommended in the catalog.
2. Pour point of lubricant selected should be at least 10°F (6°C) lower than expected minimum ambient starting temperature.
3. Extreme pressure (EP) lubricants are not necessary for average operating conditions. When properly selected for specific applications, Torque-Arm II backstops are suitable for use with EP lubricants.
4. Special lubricants may be required for food and drug industry applications where contact with the product being manufactured may occur. Consult a lubrication manufacturer's representative for his recommendations.
5. For reducers operating in ambient temperatures between -22°F (-30°C) and 20°F (-6.6°C) use a synthetic hydrocarbon lubricant, 100 ISO grade or AGMA 3 grade (for example, Mobil SHC 627). Above 125°F (51°C), consult Dodge Gear Application Engineering (864) 288-9050 for lubrication recommendation.
6. Mobil SHC 630 Series oil is recommended for high ambient temperatures.

4. Mount reducer on driven shaft as follows:
For Taper Bushed Reducer: Mount reducer on driven shaft per instruction in bushing installation section of this manual.
5. Reusing the existing reducer bolts, install the adapter plates in any suitable location on the flange of the reducer. Mount the rod assembly with the hardware included with the rod kit.
6. Install torque arm fulcrum on a flat and rigid support so that the torque arm will be approximately at right angles to the centerline through the driven shaft and the torque arm anchor screw, as shown in Figure 6.

Tie Rod should be mounted at a 90° angle in relation to the center of the driven shaft.

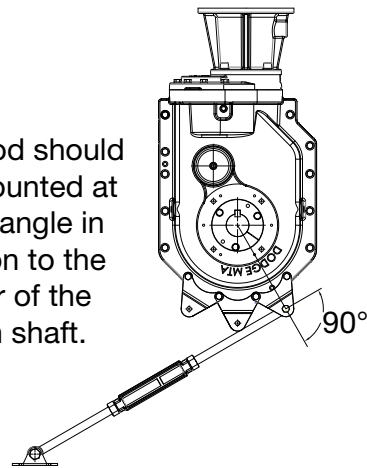

Figure 6 - Tie Rod Mount

CAUTION: Unit is shipped without oil. Add proper amount of recommended lubricant before operating. Failure to observe this precaution could result in damage to or destruction of the equipment

7. Fill gear reducer with recommended lubricant. See Table 4.

MOTORIZED TORQUE-ARM II BUSHING INSTALLATION

The Motorized Torque-Arm II reducer is designed to fit both standard and short length driven shafts. The Standard Taper Bushings series is designed where shaft length is not a concern. The Short Shaft Bushing series is to be used where the driven shaft does not extend through the reducer. The Motorized Torque-Arm II reducer is designed to accept the standard Torque-Arm II bushing series.

Standard Taper Bushings

1. One bushing assembly is required to mount the reducer on the driven shaft. An assembly consists of two tapered bushings, bushing screws and washers, two bushing backup plates and retaining rings, and necessary shaft key or keys. The driven shaft must extend through the full length of the reducer. If the driven shaft does not extend through the reducer do not use the standard tapered bushings; instead use the short shaft bushings as described in the Short Shaft Bushings section that follows. The minimum shaft length, as measured from the end of the shaft to the outer edge of the bushing flange (see Figure 8), is given in Table 6.
2. Install one bushing backup plate on the end of the hub and secure with the supplied retaining ring. Repeat procedure for other side.
3. Place one bushing, flange end first, onto the driven shaft and position per dimension A, as shown in Table 6. This will allow the bolts to be threaded into the bushing for future bushing and reducer removal.
4. Insert the output key in the shaft and bushing. For easy of installation, rotate the driven shaft so that the shaft keyseat is at the top position.

NOTE: In most cases the keys that are supplied with the bushing kit are NOT square keys and the orientation of the key is important. Install the key so that it fits snugly in the width of the keyseat. The keys are marked with a part number and some keys are also etched with "THIS SIDE UP"—these markings should be showing on the top of the key when it is installed in the shaft keyseat. See Figure 7 below.

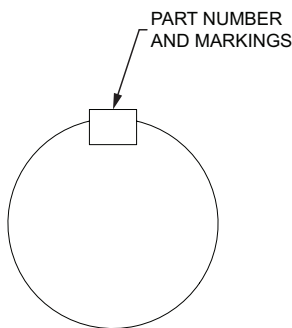

Figure 7 - Key Marking

5. Mount the reducer on the driven shaft and align the shaft key with the reducer hub keyway. Maintain the recommended minimum distance A from the shaft bearing.
6. Insert the screws, with washers installed, in the unthreaded holes in the bushing flange and align with the threaded holes in the bushing backup plate. If necessary, rotate the bushing backup plate to align with the bushing screws. Tighten the screws lightly. If the reducer must be positioned closer than dimension A, place the screws with washers installed, in the unthreaded holes in the bushing before positioning reducer making sure to maintain at least 1/8" between the screw heads and the bearing.

7. Place the second tapered bushing in position on the shaft and align the bushing keyway with the shaft key. Align the unthreaded holes in the bushing with the threaded holes in the bushing backup plate. If necessary, rotate the bushing backup plate to align with the bushing holes. Insert bushing screws, with washers installed in the unthreaded holes in the bushing. Tighten screws lightly.
8. Alternately and evenly tighten the screws in the bushing nearest the equipment to the recommended torque given in Table 6. Repeat procedure on outer bushing.

Short Shaft Bushings

1. One bushing assembly is required to mount the reducer on the driven shaft. An assembly consists of one long tapered bushing, one short tapered bushing, one tapered bushing wedge, bushing screws and washers, two bushing backup plates and two retaining rings, and necessary shaft key or keys. The driven shaft does not need to extend through the reducer for the short shaft bushing to operate properly. The minimum shaft length, as measured from the end of the shaft to the outer edge of the bushing flange (see Figure 8), is given in Table 6.

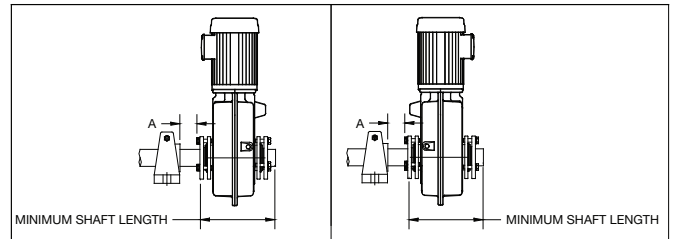

Figure 8 - Minimum Recommended Dimensions

Table 6: Minimum Mounting Dimensions and Bolt Torques

Reducer Size	Standard Taper Bushing Inch (mm)	Short Shaft Bushing Inch (mm)
MTA2115H	7.80 (198)	4.80 (122)
MTA3203H	8.55 (218)	5.46 (139)
MTA4207H	8.94 (227)	5.66 (144)
MTA5215H	10.33 (263)	6.35 (162)
MTA6307H	10.82 (275)	6.72 (171)
MTA7315H	11.87 (302)	7.62 (194)
MTA8407H	12.82 (325)	8.10 (206)

Bushing Screw Information and Minimum Clearance for Removal			
Reducer Size	Fastener Size Inch (mm)	Torque in ft-lbs (N-m)	A Inch (mm)
MTA2115H	3/8-16 (M10x1.5)	26-23 (48-43)	1.20 (36)
MTA3203H	3/8-16 (M10x1.5)	26-23 (48-43)	1.20 (36)
MTA4207H	3/8-16 (M10x1.5)	26-23 (48-43)	1.48 (38)
MTA5215H	1/2-13 (M12x1.75)	75-67 (85-80)	1.81 (48)
MTA6307H	1/2-13 (M12x1.75)	75-67 (85-80)	1.81 (48)
MTA7315H	1/2-13 (M12x1.75)	75-67 (85-80)	2.06 (53)
MTA8407H	1/2-13 (M12x1.75)	75-67 (85-80)	2.06 (53)

2. The long bushing is designed to be installed from the side of the reducer opposite the driven equipment as shown in Figure 8. The long bushing when properly installed is designed to capture the end of the customer shaft that does not extend through the reducer. Normally the reducer would be mounted such that the input shaft extends from the side of the reducer opposite the driven equipment however the reducer design allows installation of the reducer to be mounted in the opposite direction.

3. Install the tapered bushing wedge into the hollow bore of the reducer from the same side as the long bushing will be installed. When installing the tapered bushing wedge into the reducer hub, install the flange end first so that the thin taper is pointing outwards towards the long bushing as shown in Figure 9. The wedge is properly installed when it snaps into place in the reducer hub.

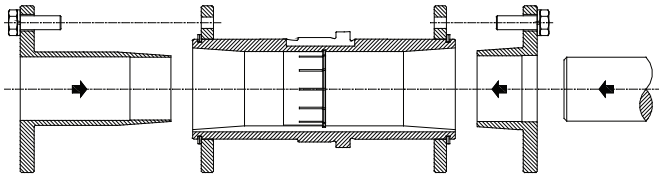

Figure 9 - Short Shaft Bushing and Output Hub Assembly

4. Align the tapered bushing wedge keyway with the reducer hub keyway. The keyway in the wedge is slightly wider than the keyway in the reducer hub allowing for easier installation.
5. Install one bushing backup plate on the end of the hub and secure with the supplied retaining ring. Repeat procedure for other side.
6. Install the short bushing; flange first, on the driven shaft and position per dimension A as shown in Table 6. This will allow the bolts to be threaded into the bushing for future bushing and reducer removal.
7. Insert the output key in the shaft and bushing. For easy of installation, rotate the driven shaft so that the shaft keyseat is at the top position.

NOTE: In most cases the keys that are supplied with the bushing kit are NOT square keys, and the orientation of the key is important. Install the key so that it fits snugly in the width of the keyseat. The keys are marked with a part number and some keys are also etched with “THIS SIDE UP”—these markings should be showing on the top of the key when it is installed in the shaft keyseat. See Figure 10 below.

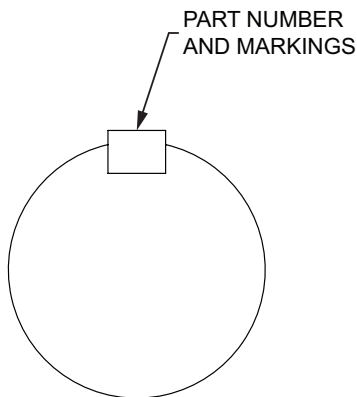

Figure 10 - Key Marking

8. Mount the reducer on the driven shaft and align the shaft key with the reducer hub keyway. Maintain the recommended minimum distance A from the shaft bearing.
9. Insert the screws, with washers installed, in the unthreaded holes in the bushing flange and align with the threaded holes in the bushing backup plate. If necessary, rotate the bushing backup plate to align with the bushing screws. Tighten the screws lightly. If the reducer must be positioned closer than dimension A, place the screws with washers installed, in the unthreaded holes in the bushing before positioning reducer making sure to maintain at least $\frac{1}{8}$ " (3mm) between the screw heads and the bearing.

10. Place the long bushing in position on the shaft and align the bushing keyway with the shaft key. Use care to locate the long bushing with the tapered bushing wedge installed earlier. Align the unthreaded holes in the bushing with the threaded holes in the bushing backup plate. If necessary, rotate the bushing backup plate to align with the bushing holes. Insert bushing screws, with washers installed in the unthreaded holes in the bushing. Tighten screws lightly.
11. Alternately and evenly tighten the screws in the bushing nearest the equipment to the recommended torque given in Table 6. Repeat procedure on outer bushing.

Bushing Removal for Standard Taper or Short Shaft Bushings

1. Remove bushing screws.
2. Place the screws in the threaded holes provided in the bushing flanges. Tighten the screws alternately and evenly until the bushings are free on the shaft. For ease of tightening screws make sure screw threads and threaded holes in the bushing flanges are clean. If the reducer was positioned closer than the recommended minimum distance A as shown in Table 6, loosen the inboard bushing screws until they are clear of the bushing flange by $\frac{1}{8}$ " (3mm). Locate two wedges at 180 degrees between the bushing flange and the bushing backup plate. Drive the wedges alternately and evenly until the bushing is free on the shaft.
3. Remove the outside bushing, the reducer, and then the inboard bushing.

LUBRICATION

NOTE: Because reducer is shipped without oil, it is necessary to add the proper amount of oil before operating reducer. Use a high-grade petroleum base rust and oxidation inhibited (R&O) gear oil—see tables. Follow instructions on reducer warning tags, and in the installation manual.

Under average industrial operating conditions, the lubricant should be changed every 2500 hours of operation or every six months, whichever occurs first. Drain reducer and flush with kerosene, clean magnetic drain plug and refill to proper level with new lubricant.

After an initial operation of about two weeks, the oil should be changed. If desired, this oil may be filtered and reused. Very often, small metal particles will show up in the oil due to the wearing in process. After the initial break-in period, the lubricant should be drained, magnetic drain plug cleaned, gear case flushed and refilled every 2500 hours of operation under average industrial conditions.

CAUTION: Too much oil will cause overheating and too little will result in gear failure. Check oil level regularly. Failure to observe this precaution could result in damage to the reducer.

Under extreme operating conditions, such as rapid rise and fall of temperature, dust, dirt, chemical particles, chemical fumes, or oil sump temperatures above 200°F (90°C), the oil should be changed every one to three months, depending on severity of conditions.

GUIDELINES FOR MOTORIZED TORQUE-ARM II REDUCER LONG-TERM STORAGE

During periods of long storage, or when waiting for delivery or installation of other equipment, special care should be taken to protect a gear reducer to have it ready to be in the best condition when placed into service.

By taking special precautions, problems such as seal leakage and reducer failure due to lack of lubrication, improper lubrication quantity, or contamination can be avoided. The following precautions will protect gear reducers during periods of extended storage.

Preparation

1. Drain oil from the unit. Add a vapor phase corrosion inhibiting oil (VCI-105 oil by Daubert Chemical Co.) in accordance with Table 7.
2. Seal the unit airtight. Replace the vent plug with a standard pipe plug and wire the vent to the unit.
3. Cover all unpainted exterior parts with a waxy rust preventative compound that will keep oxygen away from the bare metal (Non-Rust X-110 by Daubert Chemical Co. or equivalent).
4. The instruction manuals and lubrication tags are paper and must be kept dry. Either remove these documents and store them inside, or cover the unit with a durable waterproof cover which can keep moisture away.
5. Protect reducer from dust, moisture, and other contaminants by storing the unit in a dry area.
6. In damp environments, the reducer should be packed inside a moisture-proof container or an envelope of polyethylene containing a desiccant material. If the reducer is to be stored outdoors, cover the entire exterior with a rust preventative.

When Placing the Reducer into Service

1. Fill the unit to the proper oil level using a recommended lubricant. The VCI oil will not affect the new lubricant.
2. Clean the shaft extensions with petroleum solvents.
3. Assemble the vent plug into the proper hole.
4. Follow the installation instructions provided in this manual.

Table 7: Quantities of VCI #105 Oil

Reducer Size	Quantity (Ounces / Milliliter)
MTA2115H	1/30
MTA3203H	1/30
MTA4207H	1/30
MTA5215H	2/59
MTA6307H	2/59
MTA7315H	3/89
MTA8407H	3/89

VCI #105 and #10 are interchangeable.
VCI #105 is more readily available.

OIL VISCOSITY EQUIVALENCY CHART

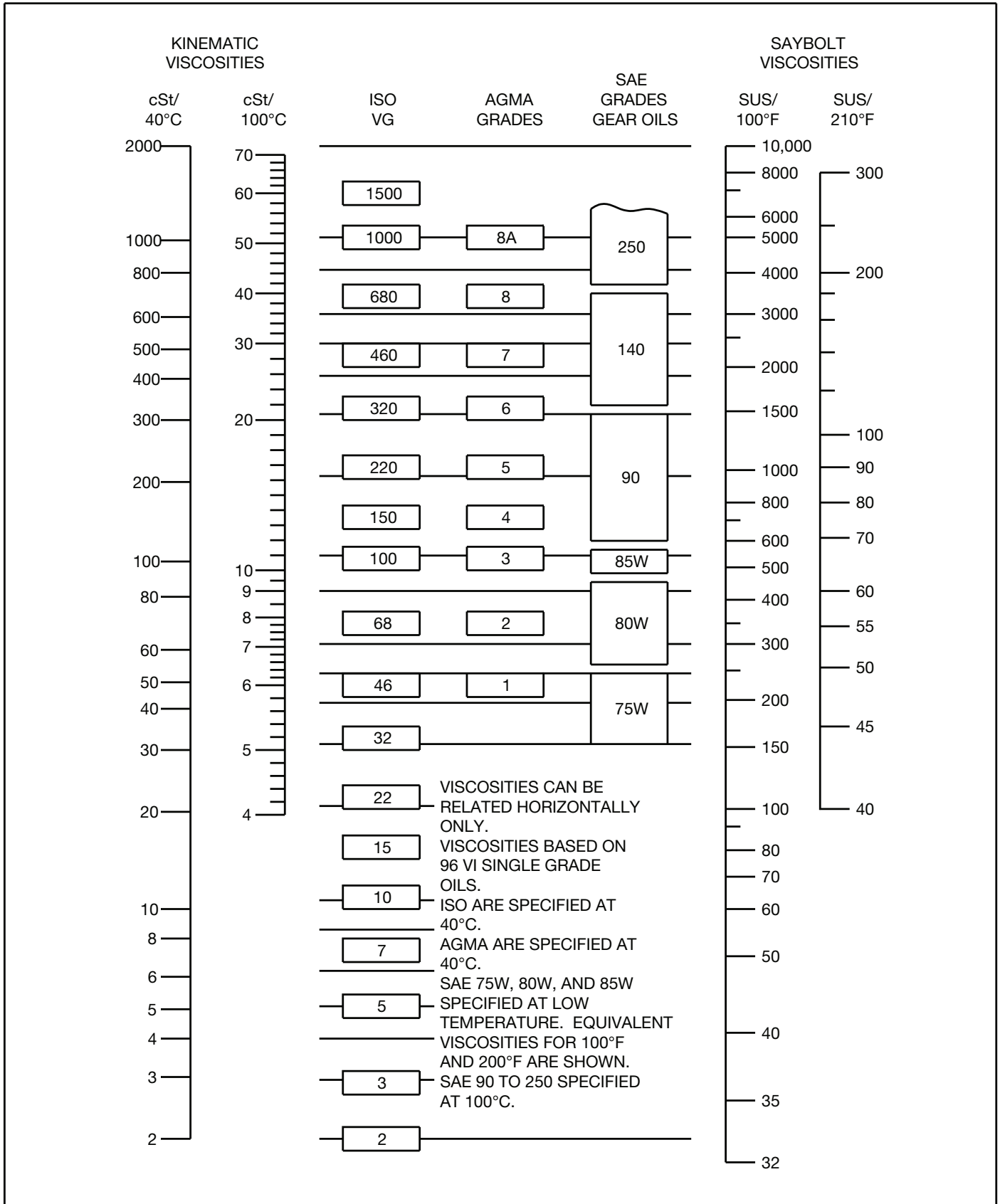

BACKSTOPS

1. Remove backstop shaft cover and gasket, shown in Figure 11. These parts will not be reused. This cover is directly opposite the extended end of the input shaft.
2. Clean the face of the gearbox to remove any gasket material or contamination from the cover mounting surface. It is important that contamination not get into the gearbox or the backstop during the backstop installation/servicing process.
3. Face reducer looking at the side from which the cover was removed. Determine carefully the desired direction of free rotation. It is important that the direction be correctly determined because to reverse the direction after the backstop is installed, it is necessary to remove the backstop, turn it end-for-end and then reinstall it.
4. Match the arrow on the backstop inner race to the direction of free rotation for the desired shaft. Note that reversing the backstop end-for-end changes the direction of the arrow. The shaft will rotate in the same direction as the arrow on the backstop.
5. If the backstop kit has a spacer ring included, install it onto the shaft first, adjacent to the bearing inner ring.
6. Install the backstop inner race and sprag cage assembly onto the shaft. DO NOT remove the cage from the inner race or the shipping strap from the sprag set at this time. Insert the key into the inner race and mating shaft keyway. These parts should slip onto the shaft easily, a light coating of oil may assist in assembly. Do not use a hammer to force the installation, damage can occur to the shaft and/or the backstop. Slide the race against the spacer or the shaft shoulder and install the retaining ring into the groove in the shaft. Only use the supplied key, as it is specifically designed for each backstop.
7. Apply a thin coating of RTV silicone onto the gearbox mating surface for the outer race (same as the cover area). It is important to apply the sealant around the fastener holes to prevent leakage. Do not allow excessive amounts of silicone to enter the gearbox or to be applied to other parts.
8. Install the outer race by gently rotating it opposite the shaft rotation while pressing lightly inwards. Do not force the outer race into position as backstop damage may occur. Once the outer race is well piloted onto the sprag set, remove the shipping strap from the sprag set by cutting it, being careful not to let the outer race back off the sprags. The outer race should slide easily into position with a slight turning motion. A light coating of oil on the race inner diameter may ease installation.
9. Align the fastener holes in the outer race with the mating holes in the gearbox. Use the supplied grade 5 fasteners and lock washers only. Torque the fasteners in an alternating pattern per Table 8.

Table 8: Backstop Fastener Torque Values

Reducer Size	Fastener Size	Torque in ft-lbs (N-m)
MTA2115H	1/4-20	8-7 (12-9)
MTA3203H	1/4-20	8-7 (12-9)
MTA4207H	5/16-18	17-15 (23-20)
MTA5215H	5/16-18	17-15 (23-20)
MTA6307H	3/8-16	30-27 (41-36)
MTA7315H	3/8-16	30-27 (41-36)
MTA8407H	3/8-16	30-27 (41-36)

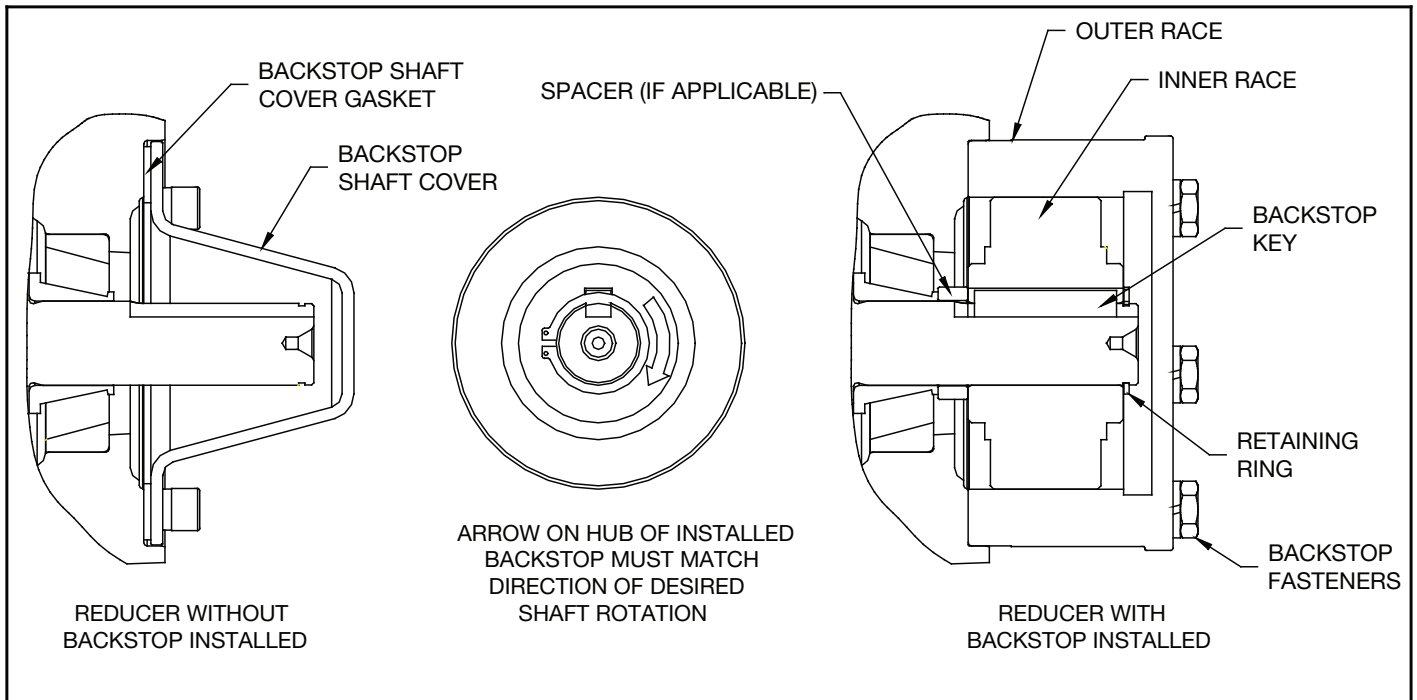

Figure 11 - Backstop Assembly

SCREW CONVEYOR ADAPTER AND DRIVESHAFT ASSEMBLY

1. Install seals (408) into adapter housing as shown in Figure 12. If the optional packing adapter is to be used, install only one seal in the small end of the adapter. Use extreme care when installing seals to avoid damage to the seals. Press or tap seals into place by applying pressure only on the outer edge of the seal. Make sure seals are installed evenly and are not tilted.
2. If using the optional packing adapter, install the two studs (413), retaining ring (412), and two nuts (414). Thread the nuts onto the studs about 4-5 threads. Install the three braided type seals (415) in a circular direction into the adapter cavity. Shoulder the braided seals against the adjustable retaining ring (412). To aid in installation of the driveshaft in step 7, the braided seals can be flattened out slightly with a soft hammer prior to installation. When installing the braided seals offset the joints from each other.
3. Lightly tap the large washer (407) into the counterbore on the large end of the adapter to seal the braided material installed in step 2 or the seal installed in step 1.
4. Place reducer on blocks so that it lays flat with the input shaft down.
5. Position screw conveyor adapter (400) on the reducer output hub so that the small end (end with four drilled holes) rests on reducer. The approximate 1/8" (3mm) piloting projection should locate in the output seal bore next to the auxiliary seal. Adapter projection should not touch the face of the gear case casting.
6. Place four adapter screws (409) and lock washers (410) through the adapter and thread into the reducer. Tighten the four cap screws (409) to the torque specified in Table 11.
7. Turn reducer onto its side. Use caution not to damage either type seals and install driveshaft through the adapter housing into the reducer. Line up the keyway in the driveshaft with the keyway in the reducer hub bore. Slide or gently tap key into reducer through the input shaft side of the output hub.
8. Install the retaining ring (411) into the screw conveyor wedge (402). Making sure the driveshaft is fully seated into the reducer, slide the wedge onto driveshaft.
9. Install keeper plate (401), driveshaft cap screw (404), and lockwasher (405). Torque to specifications in Table 11.

Driveshaft Removal

To remove the driveshaft from the reducer the following steps are required.

1. Remove the driveshaft retaining bolt (404) and lock washer (405), the keeper plate (401), and the retaining ring (411).
2. Referring to Table 9, install the correct size hex head set screw into the end of the driveshaft until flush. Note TA6307H and TA7315H do not require a set screw.
3. Position the keeper plate (401) flush against the end of the driveshaft and with the small end facing out. Next install the retaining ring (411). When properly installed, the retaining ring holds the keeper plate (401) in place.
4. Screw removal bolt(s) into the keeper plate (401) and tighten until the driveshaft wedge (402) is dislodged. Once the driveshaft wedge (402) is dislodged, pull the assembly free from the reducer. If installed, remove the hex head set screw from the end of the driveshaft. The driveshaft can now be easily removed from the reducer by pulling the driveshaft straight out of the reducer.

NOTE: The removal bolt is not the same bolt as the retaining bolt. Refer to Table 9 for the correct bolt to be used for removal.

Table 9: Removal Hardware

Reducer Size	Removal Bolt	Hex Head Set Screw
MTA2115H	3/4-10 x 2	5/8-11 x 3/4
MTA3203H	7/8-9 x 2	3/4-10 x 3/4
MTA4207H	7/8-9 x 2	3/4-10 x 3/4
MTA5215H	7/8-9 x 2	3/4-10 x 3/4
MTA6307H	3/16-18 x 2 (4 Required)	N/A
MTA7315H	3/16-18 x 2 (4 Required)	N/A
MTA8407H	N/A	N/A

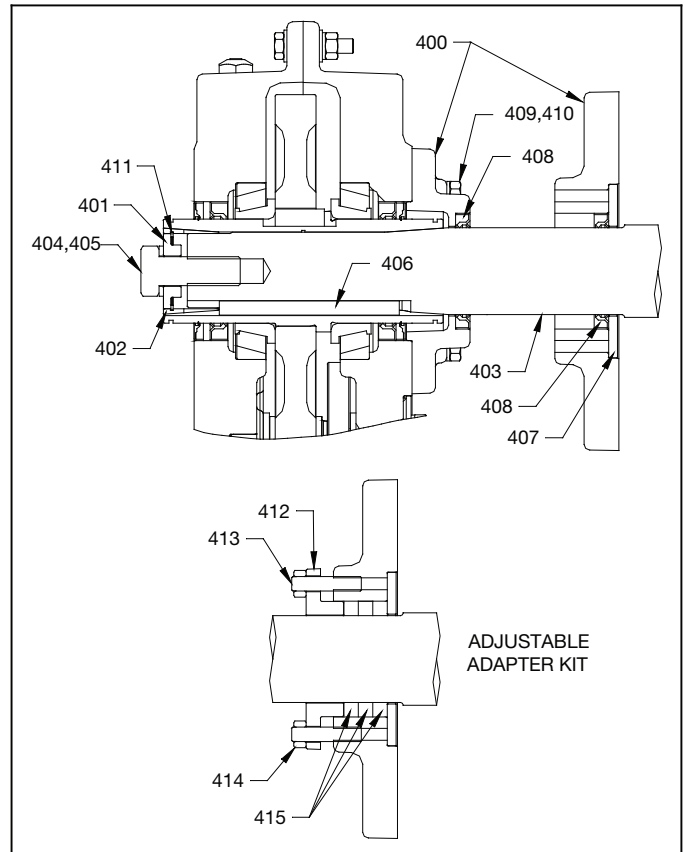

Figure 12 - Screw Conveyor Adapter Assembly

REPLACEMENT OF PARTS

NOTE: Using tools normally found in a maintenance department, a Motorized Torque-Arm II speed reducer can be disassembled and reassembled by careful attention to the following instructions.

Cleanliness is very important to prevent the introduction of dirt into the bearings and other parts of the reducer. A tank of clean solvent, an arbor press, and equipment for heating bearings and gears (for shrinking these parts on shafts) should be available.

Our factory is prepared to repair reducers for customers who do not have proper facilities or who, for any reason, desire factory service.

The oil seals are contact lip seals. Considerable care should be used during disassembly and reassembly to avoid damage to the surface on which the seals rub.

Any sharp edges on the output hub should be covered with tape or paper before disassembly or reassembly. Also, be careful to remove any burrs or nicks on surfaces of the input shaft or output hub before disassembly or reassembly.

Ordering Parts: When ordering parts for reducer, specify reducer size number, reducer model number, part name, part number, and quantity.

It is strongly recommended that, when a pinion or gear is replaced, the mating pinion or gear is replaced also. If the large gear on the output hub must be replaced, it is recommended that an output hub assembly consisting of a gear assembled on a hub be ordered to ensure undamaged surfaces on the output hub where the output seals rub. However, if it is desired to use the old output hub, press the gear and bearing off and examine the rubbing surface under the oil seal carefully for possible scratching or other damage resulting from the pressing operation. To prevent oil leakage at the shaft oil seals, the smooth surface of the output hub must not be damaged.

If any parts must be pressed from a shaft or from the output hub, this should be done before ordering parts to make sure that none of the bearings or other parts are damaged in removal. Do not press against rollers or cage of any bearing.

Because old shaft oil seals may be damaged in disassembly, it is advisable to order replacements for these parts.

REMOVING REDUCER FROM SHAFT

Removal of Tapered Bushings and Reducer

1. Disconnect and remove torque arm rod from reducer adapter.
2. Remove bushing screws from bushings.
3. Place the screws in the threaded holes provided in the bushing flanges. Tighten the screws alternately and evenly until the bushings are free on the shaft. For ease of tightening screws, make sure screw threads and threaded holes in bushing flanges are clean. A tap can be used to clean out the threads. Use caution to use the proper size tap to prevent damage to the threads.
4. Remove the outside bushing, the reducer, and then the inboard bushing.

Disassembly

1. Drain all oil from the reducer.
2. Position the reducer on its side and remove the motor assembly, front cover, and all housing bolts. Drive dowel pins from housing. Using the three pry slots around the periphery of the flange, gently separate the housing halves. Open housing evenly to prevent damage to the parts inside.
3. Lift input shaft, all gear assemblies, and bearing assemblies from housing. Remove all bolts retaining the bevel cartridge assembly and remove from housing.
4. Remove input gear from bevel pinion cartridge assembly.
5. Disassemble bevel pinion cartridge.
6. Remove all seals from housing.
7. Remove all bearings from shafts, hubs, and bevel pinion. Be careful not to scratch or damage any assembly or seal area during bearing removal. The hub assembly can be disassembled for gear replacement but if scratching or grooving occurs on the hub, seal leakage will occur and the hub will need to be replaced.

Reassembly

1. **Output Hub Assembly:** Heat gear to 325°F to 350°F (162°C to 176°C) to shrink onto hub. Heat bearings to 270°F to 290°F (132°C to 143°C) to shrink onto hub. Any damage to the hub surfaces where the oil seals rub will cause leakage, making it necessary to use a new hub.
2. **Countershaft and Bevel Gear Assembly:** Countershaft and pinion are integral. Press bevel gear and bearings on shaft. Press against inner race (not cage or rollers) of bearings.
3. **Input Shaft Assembly:** Shaft and pinion are integral. Press bearings on shaft. Press against inner race (not cage or rollers) of bearings.
4. **Bevel Bearing Cartridge Assembly:** Install the bearing cups into cartridge housing making sure bearing cups are fully seated against the bearing shoulders.
 - a. Heat bearing cone to 270°F to 290°F (132°C to 143°C) to shrink onto the bevel pinion shaft adjacent to the bevel pinion teeth. The bevel shaft and pinion are integral. If pressing is required, press against inner race (not cage or rollers) of bearing.
 - b. Slide the bevel pinion and bearing cone assembly into the bearing cartridge and set the cartridge assembly into a press with the pinion teeth facing down.
 - c. Using press, install outer bearing cone onto bevel pinion shaft using pressure per Table 10. The pressure listed is required to set correct preload. Do not press against the bevel pinion teeth as damage may occur. Press against flat surface on end of pinion only. The bevel pinion assembly should now have a slight preload.
 - d. Remove from press and install snap ring. At this time bevel assembly should be tight with no bearing end play.
 - e. Measure gap between snap ring and bearing.
 - f. Remove snap ring and add shim equal to the measured gap minus 0.0015" (.04mm) and reinstall snap ring.
 - g. Using a rubber hammer, slightly tap the end of the pinion. The bearings will slightly loosen. Verify the bearing end play setting per Table 10.
5. Place reducer housing with bevel cartridge provision on blocks to allow for protruding end of output hub during reassembly.
6. Drive the two dowel pins into place in the housing.
7. Install bearing cup for bevel gear countershaft assembly into the housing bore and install bevel gear assembly. Install the bevel pinion cartridge assembly into housing.

8. Lifting vertically upward on the bevel gear countershaft assembly, measure the movement of the countershaft assembly until the bevel gear locates tightly against the bevel pinion. Remove the bevel pinion cartridge from the housing and add shim under the bevel gear countershaft assembly per Table 10. This is the backlash setting for the bevel pinion and gear.
9. Reinstall bevel pinion cartridge assembly. Install first reduction gear and snap ring.
10. Install bearing cup on upper side of bevel gear countershaft assembly and set upper reducer housing in place. Measure and shim end play per Table 10.
11. Remove upper reducer housing and lightly coat the bevel pinion with red lead or suitable coating to check contact pattern on bevel gear.
12. Reinstall upper reducer housing and rotate input pinion 20-30 revolutions. This will transfer the red lead from the pinion to the gear teeth. Remove upper reducer housing and check tooth contact. If contact pattern is not correct, shim the bevel pinion cartridge until an acceptable pattern is achieved. This process may need to be repeated several times until correct pattern is obtained.
13. Install input shaft assembly in the housing and set input cover in place. Shim input assembly per Table 10.
14. Install remaining bearing cups into housing.
15. Install and mesh output hub gear and bevel gear countershaft assembly together and set in place in housing. Make sure bearing rollers (cones) are properly seated in their cups. Set bearing cups for opposite side housing in place on their rollers.
16. Making sure both reducer housings are clean, set opposite side housing into position onto the dowel pins and tap with a soft hammer (rawhide, not lead hammer) until housing bolts can be used to draw housing together. Make sure reducer shafts do not bind while tightening housing bolts.
17. Rotate the input pinion shaft and seat all remaining bearings with a soft hammer. Using a magnetic base and indicator, measure and record the end play of the output hub assembly. Remove upper housing and shim behind the bearing cup as required to achieve the correct bearing end play or preload per Table 10. Repeat this process and check end play until proper endplay is obtained. Note that the output shaft is preloaded. After endplay is determined, add the correct shim thickness to the end play reading to obtain the correct preload.
18. Remove upper reducer housing. Clean the flange surfaces on both housings, making sure not to nick or scratch flange face. Place a $\frac{1}{8}$ " (3mm) bead of Dow RTV732 sealant or equivalent on flange face (make sure RTV is placed around bolt holes and inside of flange face). Place opposite side housing into position onto the dowel pins and tap with a soft hammer (rawhide, not lead hammer) until housing bolts can be used to draw both housings together. Torque housing bolts per torque values listed in Table 11.
19. Install input, output, and auxiliary seals. Extreme care should be used when installing seals to avoid damage due to contact with sharp edges on the output hub. The possibility of damage and consequent oil leakage can be decreased by covering all sharp edges with tape prior to seal installation. Lightly coat the seal lips with Mobilith AW2 All-Purpose grease or equivalent. Seals should be pressed or tapped with a soft hammer evenly into place in the reducer housing, applying pressure only on the outer edge of the seals. A slight oil leakage at the seals may be evident during initial running, but should disappear unless seals have been damaged.
20. Install bushing backup plates and snap rings on taper bushed reducers.

Table 10: Bearing Adjustment Tolerance & Backlash Setting

Reducer Size	Bearing Endplay Values Inch (mm)			
	Input	Countershaft	Output	Bevel
MTA2115H	0.001-0.003 (0.025 - 0.076) Loose	0.0005-0.002.5 (0.013 - 0.064) Loose	0.002-0.004 (0.050 - 0.101) Preload	0.0005-0.0015 (0.013 - 0.038) Loose
MTA3203H	0.001-0.003 (0.025 - 0.076) Loose	0.0005-0.002.5 (0.013 - 0.064) Loose	0.002-0.004 (0.050 - 0.101) Preload	0.0005-0.0015 (0.013 - 0.038) Loose
MTA4207H	0.001-0.003 (0.025 - 0.076) Loose	0.0005-0.002.5 (0.013 - 0.064) Loose	0.002-0.004 (0.050 - 0.101) Preload	0.0005-0.0015 (0.013 - 0.038) Loose
MTA5215H	0.001-0.003 (0.025 - 0.076) Loose	0.0005-0.002.5 (0.013 - 0.064) Loose	0.006-0.008 (0.152 - 0.203) Preload	0.0005-0.0015 (0.013 - 0.038) Loose
MTA6307H	0.001-0.003 (0.025 - 0.076) Loose	0.0005-0.002.5 (0.013 - 0.064) Loose	0.006-0.008 (0.152 - 0.203) Preload	0.0005-0.0015 (0.013 - 0.038) Loose
MTA7315H	0.001-0.003 (0.025 - 0.076) Loose	0.0005-0.002.5 (0.013 - 0.064) Loose	0.006-0.008 (0.152 - 0.203) Preload	0.0005-0.0015 (0.013 - 0.038) Loose
MTA8407H	0.001-0.003 (0.025 - 0.076) Loose	0.0005-0.002.5 (0.013 - 0.064) Loose	0.006-0.008 (0.152 - 0.203) Preload	0.0005-0.0015 (0.013 - 0.038) Loose

Table 11: Recommended Bolt Torque Values

Housing Bolt Recommended Torque Values		
Reducer Size	Fastener Size	Torque in ft-lbs (N-m)
MTA2115H	3/8-16	30 - 27 (41 - 37)
MTA3203H	3/8-16	30 - 27 (41 - 37)
MTA4207H	1-2/13	75 - 70 (102 - 95)
MTA5215H	1-2/13	75 - 70 (102 - 95)
MTA6307H	1/2-13	75 - 70 (102 - 95)
MTA7315H	5/8-11	115 - 110 (156 - 149)
MTA8407H	5/8-11	115 - 110 (156 - 149)

Backstop Cover Bolt Recommended Torque Values		
Reducer Size	Fastener Size	Torque in ft-lbs (N-m)
MTA2115H	1/4-20	8 - 7 (11 - 10)
MTA3203H	1/4-20	8 - 7 (11 - 10)
MTA4207H	5/16-18	17 - 15 (23 - 20)
MTA5215H	5/16-18	17 - 15 (23 - 20)
MTA6307H	3/8-16	30 - 27 (41 - 37)
MTA7315H	3/8-16	30 - 27 (41 - 37)
MTA8407H	3/8-16	30 - 27 (41 - 37)

Screw Conveyor Adapter Bolt Recommended Torque Values		
Reducer Size	Fastener Size	Torque in ft-lbs (N-m)
MTA2115H	7/16-14	50 - 45 (68 - 61)
MTA3203H	1/2-13	75 - 70 (102 - 95)
MTA4207H	1/2-13	75 - 70 (102 - 95)
MTA5215H	5/8-11	115 - 110 (156 - 149)
MTA6307H	3/4-10	205 - 200 (278 - 271)
MTA7315H	3/4-10	205 - 200 (278 - 271)
MTA8407H	N/A	N/A

Screw Conveyor Drive Shaft Retainer Bolt Recommended Torque Values		
Reducer Size	Fastener Size	Torque in ft-lbs (N-m)
MTA2115H	5/8-11	115 - 110 (156 - 149)
MTA3203H	3/4-10	205 - 200 (278 - 271)
MTA4207H	3/4-10	205 - 200 (278 - 271)
MTA5215H	3/4-10	205 - 200 (278 - 271)
MTA6307H	1"-8	215 - 210 (292 - 285)
MTA7315H	1"-8	215 - 210 (292 - 285)
MTA8407H	N/A	N/A

REPLACEMENT BEARING NUMBERS

Table 12: Dodge and Manufacturer Part Numbers for Replacement Bearings

Reducer Size	Output Hub Bearing – LH and RH Sides
	Dodge Part Number
MTA2115H	403003/402003
MTA3203H	903252/402268
MTA4207H	403016/402193
MTA5215H	403140/402050
MTA6307H	906250/906251
MTA7315H	403105/402147
MTA8407H	403105/402147

Reducer Size	Countershaft Bearing – LH and RH Side
	Dodge Part Number
MTA2115H	403000/402000
MTA3203H	472041/472040
MTA4207H	403005/304717
MTA5215H LH	403159/907260
MTA5215H RH	304841/304750
MTA6307RH	451644/451643
MTA6307LH	411626-06-BE/411626-05BM
MTA7315H LH	411626-06-BE/411626-05-BM
MTA7315H RH	304802/402041
MTA8407H	403080/402114

Reducer Size	Bevel Pinion Bearing
	Dodge Part Number
MTA2115H	403094/402283
MTA3203H INNER	304809/304710
MTA3203H OUTER	403000/402000
MTA4207H	454444/454445
MTA5215H INNER	402297
MTA5215H OUTER	403005/304717
MTA6307H	402296/402297
MTA7315H	472168/472165
MTA8407H INNER	304802/402041
MTA8407H OUTER	472260/472259

Reducer Size	Input Shaft Bearing – LH and RH Sides
	Dodge Part Number
MTA2115H	304836/304743
MTA3203H	304836/304743
MTA4207H	403000/402000
MTA5215H	403000/402000
MTA6307H	402292/402293
MTA7315H	472041/472040
MTA8407H	403005/304717

NOTE: Bearing part numbers refer to Tapered Roller Bearing Cup/Cone combinations and apply to all ratios unless otherwise specified. For actual reducer ratios, refer to Table 13.

Parts for MTA2115H through MTA8407H Taper Bushed C-Face Reducers

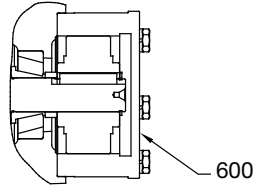
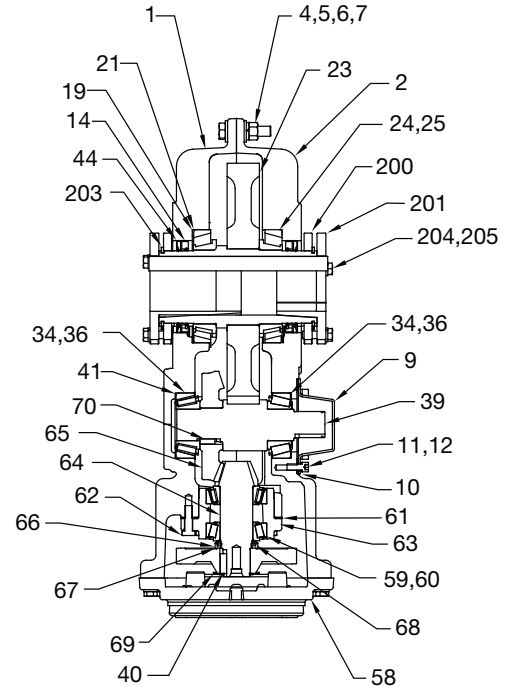
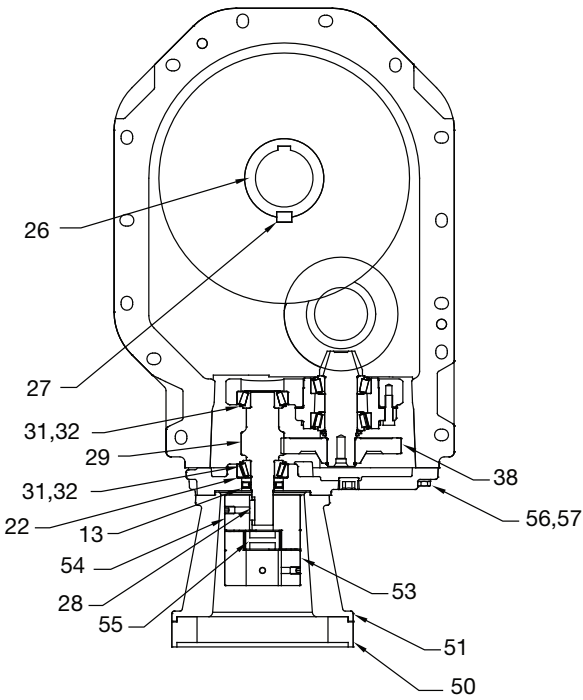

OPTIONAL BACKSTOP ASSEMBLY

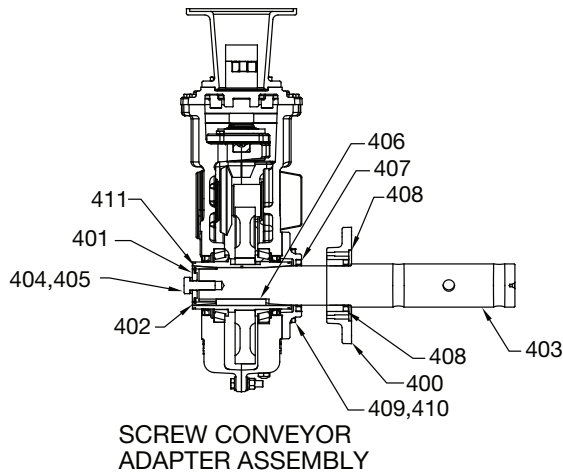

SCREW CONVEYOR ADAPTER ASSEMBLY

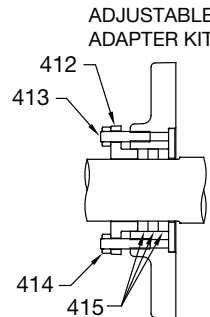

ADJUSTABLE ADAPTER KIT

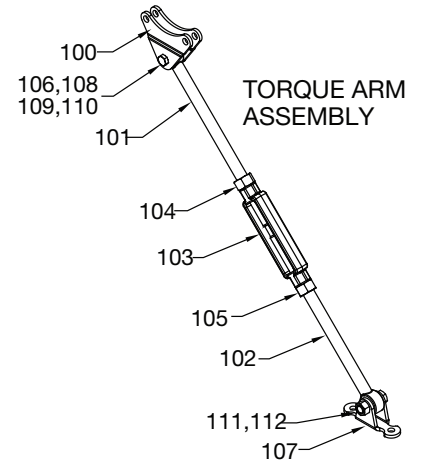

TORQUE ARM ASSEMBLY

Parts for MTA2115H through MTA8407H Taper Bushed C-Face Reducers

Ref	Description	Qty	MTA2115H	MTA3203H	MTA4207H	MTA5215H	MTA6307H	MTA7315H	MTA8407H
1	Housing-LH	1	454262	472012	454388	454671	454514	472116	472213
2	Housing-RH	1	454266	472016	454392	454674	454518	472113	472216
①	RTV Sealant, Tube	1	415112-80-H	415112-80-H	415112-80-H	415112-80-H	415112-80-H	415112-80-H	415112-80-H
4	Housing Bolt	-	032018014CR (14)	032018014CR (14)	032018018DR (14)	032018018DR (13)	032018022DR (14)	032018022ER (16)	032018022ER (17)
5	Flat Washer	-	902241ZP (28)	902241ZP (28)	904241ZP (28)	904241ZP (26)	904241ZP (28)	907241ZP (32)	907241ZP (34)
6	Nut	-	033102014AM (14)	33102014AM (14)	033102016AM (14)	033102016AM (13)	033102016AM (14)	033102018AM (16)	033102018AM (17)
7	Lock Washer	-	034017014AF (14)	034017014AF (14)	034017016AF (14)	034017016AF (13)	034017016AF (14)	034017018AF (16)	034017018AF (17)
8 ①	Dowel Pin	2	304624	472048	304624	304624	304624	420145	420145
9	Backstop Shaft Cover	1	903279P	904279P	905279P	906279P	907279P	910279P	912279P
10	Backstop Cover Gasket	1	903280	904280	905280	906280	907280	910280	912280
11	Backstop Cover Screw	-	032130004AF (6)	032130004AF (6)	032130006BF (8)	032130006BF (8)	032130006CF (12)	032130006CF (12)	032130006CF (12)
12	Backstop Lock Washer	-	034020012AE (6)	034020012AE (6)	034020013AE (8)	034020013AE (8)	034020014AE (8)	034020014AE (12)	034020014AE (12)
13	Input Oil Seal		334271	334271	334273	334273	A73106	334274	334275
14	Output Oil Seal	2	902286	A73109	904286	905286	906286	907286	907286
15 ①	Air Vent	1	900287	900287	904287	904287	904287	904287	904287
16 ①	Bushing	1	N/A	N/A	430079	430079	430079	N/A	N/A
17 ①	Oil Plug	-	430031 (6)	430031 (6)	430035 (5)	430035 (5)	430035 (5)	430035 (5)	430035 (6)
17	Smart Sensor Adapter	1	966905	966905	966907	966907	966907	966907	966907
18 ①	Magnetic Oil Plug	1	430060	430060	430064	430064	430064	430064	430064
19	Bearing Spacer	1	902594	903594	904594	905594	906594	907594	907594
21	Output Bearing Shim - As Required								
	.015" Shim	2	902263	903263	904263	905271	906263	907263	907263
	.007" Shim	2	902265	903265	904265	905273	906265	907265	907265
	.005" Shim	2	902264	903264	904264	905272	906264	907264	907264
22	Input Bearing Shim - As Required								
	.015" Shim	2	901271	901271	N/A	N/A	454582	907271	907271
	.010" Shim	2	N/A	N/A	334327	334327	N/A	N/A	N/A
	.007" Shim	2	901273	901273	N/A	N/A	454581	907273	907273
	.006" Shim	2	N/A	N/A	334326	334326	N/A	N/A	N/A
	.005" Shim	2	901272	901272	N/A	N/A	454580	907272	907272
	.003" Shim	2	N/A	N/A	334325	334325	N/A	N/A	N/A
23	Output Gear	1	902208	903208	904208	905208	906208	472133	472233
24	Output Bearing Cup	2	403003	903252	403016	403140	906250	403105	403105
25	Output Bearing Cone	2	402003	402268	402193	402050	906251	402147	402147
26	Output Hub	1	902230	903230	904230	905230	906230	907230	908230
27	Output Gear Key	1	901275	903275	904275	905275	906275	907275	908275
28	Input Pinion Key		443007	443007	443409	443409	443013	443182	472248
29	Input Pinion ⑥								
	14:1 Ratio	1	N/A	454289	454414	454414	454541	472137	472237
	15:1 Ratio	1	454289	N/A	N/A	N/A	N/A	N/A	N/A
	17:1 Ratio	1	N/A	454290	N/A	N/A	N/A	N/A	472238
	18:1 Ratio	1	454290	N/A	454415	454415	N/A	N/A	N/A
	19:1 Ratio	1	N/A	N/A	N/A	N/A	454542	472138	N/A
	21:1 Ratio	1	454291	454291	N/A	454416	N/A	N/A	N/A
	22:1 Ratio	1	N/A	N/A	454416	N/A	454543	472139	N/A
	23:1 Ratio	1	N/A	N/A	N/A	N/A	N/A	N/A	472239
	24:1 Ratio	1	N/A	N/A	N/A	N/A	454544	N/A	N/A
	25:1 Ratio	1	454292	454292	N/A	454417	N/A	N/A	N/A
	26:1 Ratio	1	N/A	N/A	454417	N/A	N/A	472140	N/A
	27:1 Ratio	1	N/A	N/A	N/A	N/A	N/A	N/A	472240
	29:1 Ratio	1	N/A	454293	N/A	454418	454545	472141	N/A
	30:1 Ratio	1	454293	N/A	454418	N/A	N/A	N/A	N/A
	31:1 Ratio	1	N/A	N/A	N/A	N/A	N/A	N/A	472241
	32:1 Ratio	1	454294	454294	N/A	N/A	N/A	N/A	N/A
	33:1 Ratio	1	N/A	N/A	N/A	N/A	N/A	472142	N/A
	34:1 Ratio	1	N/A	N/A	454419	454419	454546	N/A	472242
	35:1 Ratio	1	N/A	454295	N/A	N/A	N/A	N/A	N/A
	36:1 Ratio	1	454295	N/A	N/A	N/A	N/A	N/A	N/A

Parts for MTA2115H through MTA8407H Taper Bushed C-Face Reducers

Ref	Description	Qty	MTA2115H	MTA3203H	MTA4207H	MTA5215H	MTA6307H	MTA7315H	MTA8407H
	38:1 Ratio	1	N/A	454296	N/A	N/A	N/A	472143	N/A
	39:1 Ratio	1	454296	N/A	N/A	N/A	454547	N/A	N/A
	40:1 Ratio	1	N/A	N/A	N/A	454420	N/A	N/A	472243
	41:1 Ratio	1	N/A	N/A	454420	N/A	N/A	N/A	N/A
	43:1 Ratio	1	N/A	N/A	N/A	454421	N/A	N/A	N/A
	44:1 Ratio	1	454297	454297	454421	N/A	N/A	472144	N/A
	45:1 Ratio	1	N/A	N/A	N/A	N/A	454548	N/A	N/A
	46:1 Ratio	1	N/A	N/A	N/A	N/A	N/A	N/A	472244
	47:1 Ratio	1	454298	454298	N/A	N/A	N/A	N/A	N/A
	48:1 Ratio	1	N/A	N/A	N/A	454422	N/A	N/A	N/A
	49:1 Ratio	1	N/A	N/A	454422	N/A	N/A	N/A	N/A
	50:1 Ratio	1	N/A	N/A	N/A	N/A	454546	472142	N/A
	51:1 Ratio	1	454299	454299	N/A	454419	N/A	472146	472242
	52:1 Ratio	1	N/A	N/A	454419	N/A	454549	N/A	N/A
	53:1 Ratio	1	N/A	N/A	N/A	N/A	N/A	N/A	472245
	58:1 Ratio	1	454296	454296	N/A	N/A	N/A	472143	N/A
	59:1 Ratio	1	N/A	N/A	N/A	N/A	454547	N/A	N/A
	60:1 Ratio	1	N/A	N/A	N/A	454420	N/A	N/A	472243
	61:1 Ratio	1	N/A	N/A	454420	N/A	N/A	N/A	N/A
	65:1 Ratio	1	N/A	454297	N/A	454421	N/A	N/A	N/A
	66:1 Ratio	1	454297	N/A	454421	N/A	N/A	N/A	N/A
	67:1 Ratio	1	N/A	N/A	N/A	N/A	454548	472145	N/A
	69:1 Ratio	1	N/A	N/A	N/A	N/A	N/A	N/A	472244
	70:1 Ratio	1	N/A	454298	N/A	N/A	N/A	N/A	N/A
	71:1 Ratio	1	454298	N/A	N/A	N/A	N/A	N/A	N/A
	72:1 Ratio	1	N/A	N/A	N/A	454422	N/A	N/A	N/A
	74:1 Ratio	1	N/A	N/A	454422	N/A	N/A	N/A	N/A
	76:1 Ratio	1	N/A	454299	N/A	N/A	N/A	472146	N/A
	77:1 Ratio	1	454299	N/A	N/A	N/A	N/A	N/A	N/A
	79:1 Ratio	1	N/A	N/A	N/A	N/A	454549	N/A	472245
31	Input Bearing Cup	2	304836	304836	403000	403000	402292	472041	403005
32	Input Bearing Cone	2	304743	304743	402000	402000	402293	472040	304717
34	Counter-Shaft Bearing Cup (LH)	1	403000	472041	403005	403159	411626-06-BE	411626-06-BE	403080
	Counter-Shaft Bearing Cup (RH)	1	403000	472041	403005	304750	451644	304802	403080
36	Counter-Shaft Bearing Cone (LH)	1	402000	472040	304717	907260	411626-05-BM	411626-05-BM	402114
	Counter-Shaft Bearing Cone (RH)	1	402000	472040	304717	304841	451643	402041	401114
38	First Stage Gear ④								
	14:1 Ratio	1	N/A	083581	083488	083488	083496	081759	081760
	15:1 Ratio	1	083451	N/A	N/A	N/A	N/A	N/A	N/A
	17:1 Ratio	1	N/A	083538	N/A	N/A	N/A	N/A	081761
	18:1 Ratio	1	083538	N/A	083489	083489	N/A	N/A	N/A
	19:1 Ratio	1	N/A	N/A	N/A	N/A	083498	083491	N/A
	21:1 Ratio	1	083510	083510	N/A	083452	N/A	N/A	N/A
	22:1 Ratio	1	N/A	N/A	083452	N/A	083494	081756	N/A
	23:1 Ratio	1	N/A	N/A	N/A	N/A	N/A	N/A	081750
	24:1 Ratio	1	N/A	N/A	N/A	N/A	081746	N/A	N/A
	25:1 Ratio	1	083480	083480	N/A	083439	N/A	N/A	N/A
	26:1 Ratio	1	N/A	N/A	083539	N/A	N/A	081753	N/A
	27:1 Ratio	1	N/A	N/A	N/A	N/A	N/A	N/A	081757
	29:1 Ratio	1	N/A	083475	N/A	083509	081722	081747	N/A
	30:1 Ratio	1	083475	N/A	083509	N/A	N/A	N/A	N/A
	31:1 Ratio	1	N/A	N/A	N/A	N/A	N/A	N/A	081754
	32:1 Ratio	1	083434	083434	N/A	N/A	N/A	N/A	N/A
	33:1 Ratio	1	N/A	N/A	N/A	N/A	N/A	081723	N/A
	34:1 Ratio	1	N/A	N/A	083481	083481	081718	N/A	081748
	35:1 Ratio	1	N/A	083427	N/A	N/A	N/A	N/A	N/A
	36:1 Ratio	1	083427	N/A	N/A	N/A	N/A	N/A	N/A
	38:1 Ratio	1	N/A	083420	N/A	N/A	N/A	081719	N/A
	39:1 Ratio	1	083420	N/A	N/A	N/A	081743	N/A	N/A
	40:1 Ratio	1	N/A	N/A	N/A	083476	N/A	N/A	081724
	41:1 Ratio	1	N/A	N/A	083476	N/A	N/A	N/A	N/A
	43:1 Ratio	1	N/A	N/A	N/A	083435	N/A	N/A	N/A

Parts for MTA2115H through MTA8407H Taper Bushed C-Face Reducers

Ref	Description	Qty	MTA2115H	MTA3203H	MTA4207H	MTA5215H	MTA6307H	MTA7315H	MTA8407H
	44:1 Ratio	1	083387	083387	083435	N/A	N/A	081715	N/A
	45:1 Ratio	1	N/A	N/A	N/A	N/A	081740	N/A	N/A
	46:1 Ratio	1	N/A	N/A	N/A	N/A	N/A	N/A	081720
	47:1 Ratio	1	083413	083413	N/A	N/A	N/A	N/A	N/A
	48:1 Ratio	1	N/A	N/A	N/A	083428	N/A	N/A	N/A
	49:1 Ratio	1	N/A	N/A	083428	N/A	N/A	N/A	N/A
	50:1 Ratio	1	N/A	N/A	N/A	N/A	081718	081737	N/A
	51:1 Ratio	1	N/A	083382	N/A	083481	N/A	081741	081748
	52:1 Ratio	1	N/A	N/A	083481	N/A	081737	N/A	081716
	53:1 Ratio	1	N/A	N/A	N/A	N/A	N/A	N/A	N/A
	58:1 Ratio	1	083420	083420	N/A	N/A	N/A	081743	N/A
	59:1 Ratio	1	N/A	N/A	N/A	N/A	081743	N/A	N/A
	60:1 Ratio	1	N/A	N/A	N/A	083476	N/A	N/A	081724
	61:1 Ratio	1	N/A	N/A	083476	N/A	N/A	N/A	N/A
	65:1 Ratio	1	N/A	083387	N/A	083435	N/A	N/A	N/A
	66:1 Ratio	1	083387	N/A	083435	N/A	N/A	N/A	N/A
	67:1 Ratio	1	N/A	N/A	N/A	N/A	081740	081740	N/A
	69:1 Ratio	1	N/A	N/A	N/A	N/A	N/A	N/A	081720
	70:1 Ratio	1	N/A	083413	N/A	N/A	N/A	N/A	N/A
	71:1 Ratio	1	083413	N/A	N/A	N/A	N/A	N/A	N/A
	72:1 Ratio	1	N/A	N/A	N/A	083428	N/A	N/A	N/A
	74:1 Ratio	1	N/A	N/A	083428	N/A	N/A	N/A	N/A
	76:1 Ratio	1	N/A	083382	N/A	N/A	N/A	081737	N/A
	77:1 Ratio	1	083382	N/A	N/A	N/A	N/A	N/A	N/A
	79:1 Ratio	1	N/A	N/A	N/A	N/A	081737	N/A	081716
39	Counter-Shaft Pinion	1	454303	472033	454429	454683	454555	472131	472231
40	First Stage Gear Key	1	094732	094732	102044	102044	690880	087699	087712
41	Counter-Shaft Bearing Shim-As Req'd								
	.015" Shim	2	454307	903267	905271	906271	907271	907271	904263
	.007" Shim	2	454306	903269	905273	906273	907273	907273	904265
	.005" Shim	2	454305	903268	905272	906272	907272	907272	904264
44	Auxiliary Output Seal	2	902236	903236	904236	905236	906236	907236	907236
50	Adapter Plate - NEMA								
	56C/140TC	1	N/A	N/A	N/A	N/A	N/A	N/A	N/A
	180TC	1	N/A	N/A	N/A	N/A	N/A	N/A	N/A
	210TC	1	N/A	N/A	N/A	N/A	N/A	N/A	N/A
	250TC	1	N/A	N/A	N/A	N/A	N/A	N/A	N/A
	280TC	1	N/A	N/A	N/A	N/A	N/A	N/A	N/A
	280TSC	1	N/A	N/A	N/A	N/A	N/A	N/A	N/A
	320TC	1	N/A	N/A	N/A	N/A	N/A	N/A	N/A
	320TSC	1	N/A	N/A	N/A	N/A	N/A	N/A	N/A
	360TC	1	N/A	N/A	N/A	454450	454450	454450	454450
	360TSC	1	N/A	N/A	N/A	N/A	N/A	N/A	N/A
	405TC	1	N/A	N/A	N/A	N/A	N/A	472171	472171
	405TSC	1	N/A	N/A	N/A	N/A	N/A	454472	454472
50	Adapter Plate - IEC								
	IEC 90	1	N/A	N/A	N/A	N/A	N/A	N/A	N/A
	IEC 100	1	N/A	N/A	N/A	N/A	N/A	N/A	N/A
	IEC 112	1	N/A	N/A	N/A	N/A	N/A	N/A	N/A
	IEC 132	1	454602	454602	454602	454602	454602	N/A	N/A
	IEC 160	1	N/A	N/A	N/A	N/A	N/A	N/A	N/A
	IEC 180	1	N/A	N/A	N/A	N/A	N/A	N/A	N/A
	IEC 200	1	N/A	N/A	N/A	N/A	N/A	N/A	N/A
	IEC 225	1	N/A	N/A	N/A	454595	454595	454595	454595
	IEC 250	1	N/A	N/A	N/A	N/A	N/A	N/A	N/A
	IEC 280	1	N/A	N/A	N/A	N/A	N/A	N/A	N/A
51	Motor Adapter - NEMA								
	56C/140TC	1	454351	N/A	N/A	N/A	N/A	N/A	N/A
	180TC	1	454401	454401	454401	454401	454401	454401	454401
	210TC	1	454402	454402	454402	454402	454402	454402	454402
	250TC	1	454405	454405	454405	454405	454405	454405	454405
	280TC	1	N/A	454404	454404	454404	454404	454404	454404

Parts for MTA2115H through MTA8407H Taper Bushed C-Face Reducers

Ref	Description	Qty	MTA2115H	MTA3203H	MTA4207H	MTA5215H	MTA6307H	MTA7315H	MTA8407H
	280TSC	1	N/A	454466	454466	454466	454466	454466	454466
	320TC	1	N/A	N/A	454409	454409	454409	454409	454409
	320TSC	1	N/A	N/A	454469	454469	454469	454469	454469
	360TC	1	N/A	N/A	N/A	454409	454409	454409	454409
	360TSC	1	N/A	N/A	454469	454469	454469	454469	454469
	405TC	1	N/A	N/A	N/A	N/A	N/A	454409	454409
	405TSC	1	N/A	N/A	N/A	N/A	N/A	454469	454469
51	Motor Adapter - IEC								
	IEC 90	1	454600	N/A	N/A	N/A	N/A	N/A	N/A
	IEC 100	1	454601	454601	N/A	N/A	N/A	N/A	N/A
	IEC 112	1	454601	454601	454601	454601	N/A	N/A	N/A
	IEC 132	1	454601	454601	454601	454601	454601	N/A	N/A
	IEC 160	1	454604	454604	454604	454604	454604	454604	N/A
	IEC 180	1	N/A	N/A	454604	454604	454604	454604	454604
	IEC 200	1	N/A	N/A	454606	454606	454606	454606	454606
	IEC 225	1	N/A	N/A	N/A	454594	454594	454594	454594
	IEC 225S	1	N/A	N/A	N/A	454594	454594	454594	454594
	IEC 250	1	N/A	N/A	N/A	N/A	N/A	472183	472183
	IEC250S	1	N/A	N/A	N/A	N/A	N/A	472183	472183
	IEC 280	1	N/A	N/A	N/A	N/A	N/A	472183	472183
	IEC 280S	1	N/A	N/A	N/A	N/A	N/A	472183	472183
53	Motor Coupling - NEMA								
	56C	1	L110X5/8	N/A	N/A	N/A	N/A	N/A	N/A
	140TC	1	L110X7/8	N/A	N/A	N/A	N/A	N/A	N/A
	180TC	1	L110X1-1/8	L110X1-1/8	L150X1-1/8	L150X1-1/8	L150X1-1/8	L150X1-1/8	L150X1-1/8
	210TC	1	L110X1-3/8	L110X1-3/8	L150X1-3/8	L150X1-3/8	L150X1-3/8	L150X1-3/8	L150X1-3/8
	250TC	1	L110X1-5/8	L110X1-5/8	L150X1-5/8	L150X1-5/8	L150X1-5/8	L150X1-5/8	L150X1-5/8
	280TC	1	N/A	L150X1-7/8	L150X1-7/8	L150X1-7/8	L150X1-7/8	L150X1-7/8	L150X1-7/8
	280TSC	1	N/A	L150X1-5/8	L150X1-5/8	L150X1-5/8	L150X1-5/8	L150X1-5/8	L150X1-5/8
	320TC	1	N/A	N/A	L225X2-1/8	L225X2-1/8	L225X2-1/8	L225X2-1/8	L225X2-1/8
	320TSC	1	N/A	N/A	L150X1-7/8	L150X1-7/8	L150X1-7/8	L150X1-7/8	L150X1-7/8
	360TC	1	N/A	N/A	N/A	L225X2-3/8	L225X2-3/8	L225X2-3/8	L225X2-3/8
	360TSC	1	N/A	N/A	L150X1-7/8	L150X1-7/8	L150X1-7/8	L150X1-7/8	L150X1-7/8
	405TC	1	N/A	N/A	N/A	N/A	N/A	472172	472172
	405TSC	1	N/A	N/A	N/A	N/A	N/A	L225X2-1/8	L225X2-1/8
53	Motor Coupling - IEC								
	IEC 90	1	L110X24MM	N/A	N/A	N/A	N/A	N/A	N/A
	IEC 100	1	L110X28MM	L110X28MM	L150X28MM	L150X28MM	N/A	N/A	N/A
	IEC 112	1	L110X28MM	L110X28MM	L150X28MM	L150X28MM	N/A	N/A	N/A
	IEC 132	1	L110X38MM	L110X38MM	L150X38MM	L150X38MM	L150X38MM	L150X38MM	N/A
	IEC 160	1	L110X42MM	L110X42MM	L150X42MM	L150X42MM	L150X42MM	L150X42MM	L150X42MM
	IEC 180	1	N/A	N/A	L150X48MM	L150X48MM	L150X48MM	L150X48MM	L150X48MM
	IEC 200	1	N/A	N/A	L225X55MM	L225X55MM	L225X55MM	L225X55MM	L225X55MM
	IEC 225	1	N/A	N/A	N/A	L225X60MM	L225X60MM	L225X60MM	L225X60MM
	IEC 225S	1	N/A	N/A	N/A	L225X55MM	L225X55MM	L225X55MM	L225X55MM
	IEC 250	1	N/A	N/A	N/A	N/A	N/A	472186	472186
	IEC 250S	1	N/A	N/A	N/A	N/A	N/A	472189	472189
	IEC 280	1	N/A	N/A	N/A	N/A	N/A	472184	472184
	IEC 280S	1	N/A	N/A	N/A	N/A	N/A	472186	472186
54	Reducer Coupling - NEMA								
	56C/140TC	1	L110X11/16	N/A	N/A	N/A	N/A	N/A	N/A
	180TC	1	L110X11/16	L110X11/16	L150X1-1/16	L150X1-1/16	L150X1-3/16	L150X1-3/8	L150X1-7/16
	210TC	1	L110X11/16	L110X11/16	L150X1-1/16	L150X1-1/16	L150X1-3/16	L150X1-3/8	L150X1-7/16
	250TC	1	L110X11/16	L110X11/16	L150X1-1/16	L150X1-1/16	L150X1-3/16	L150X1-3/8	L150X1-7/16
	280TC	1	N/A	L150X11/16	L150X1-1/16	L150X1-1/16	L150X1-3/16	L150X1-3/8	L150X1-7/16
	280TSC	1	N/A	L150X11/16	L150X1-1/16	L150X1-1/16	L150X1-3/16	L150X1-3/8	L150X1-7/16
	320TC	1	N/A	N/A	L225X1-1/16	L225X1-1/16	L225X1-3/16	L225X1-3/8	L225X1-7/16
	320TSC	1	N/A	N/A	L150X1-1/16	L150X1-1/16	L150X1-3/16	L150X1-3/8	L150X1-7/16
	360TC	1	N/A	N/A	N/A	L225X1-1/16	L225X1-3/16	L225X1-3/8	L225X1-7/16
	360TSC	1	N/A	N/A	L150X1-1/16	L150X1-1/16	L150X1-3/16	L150X1-3/8	L150X1-7/16
	405TC	1	N/A	N/A	N/A	N/A	N/A	472173	472263
	405TSC	1	N/A	N/A	N/A	N/A	N/A	L225X1-3/8	L225X1-7/16

Parts for MTA2115H through MTA8407H Taper Bushed C-Face Reducers

Ref	Description	Qty	MTA2115H	MTA3203H	MTA4207H	MTA5215H	MTA6307H	MTA7315H	MTA8407H
54	Reducer Coupling - IEC								
	IEC 90	1	L110X11/16	N/A	N/A	N/A	N/A	N/A	N/A
	IEC 100	1	L110X11/16	L110X11/16	L150X1-1/16	L150X1-1/16	N/A	N/A	N/A
	IEC 112	1	L110X11/16	L110X11/16	L150X1-1/16	L150X1-1/16	N/A	N/A	N/A
	IEC 132	1	L110X11/16	L110X11/16	L150X1-1/16	L150X1-1/16	L150X1-3/16	L150X1-3/8	N/A
	IEC 160	1	L110X11/16	L110X11/16	L150X1-1/16	L150X1-1/16	L150X1-3/16	L150X1-3/8	L150X1-7/16
	IEC 180	1	N/A	N/A	L150X1-1/16	L150X1-1/16	L150X1-3/16	L150X1-3/8	L150X1-7/16
	IEC 200	1	N/A	N/A	L225X1-1/16	L225X1-1/16	L225X1-3/16	L225X1-3/8	L225X1-7/16
	IEC 225	1	N/A	N/A	N/A	L225x1-1/16	L225X1-3/16	L225X1-3/8	L225X1-7/16
	IEC 225S	1	N/A	N/A	N/A	L225x1-1/16	L225X1-3/16	L225X1-3/8	L225X1-7/16
	IEC 250	1	N/A	N/A	N/A	N/A	N/A	472173	472263
	IEC 250S	1	N/A	N/A	N/A	N/A	N/A	472173	472263
	IEC 280	1	N/A	N/A	N/A	N/A	N/A	472173	472263
	IEC 280S	1	N/A	N/A	N/A	N/A	N/A	472173	472263
55	Coupling Element - NEMA								
	56C/140TC	1	L110N	N/A	N/A	N/A	N/A	N/A	N/A
	180TC	1	L110N	L110N	L150N	L150N	L150N	L150N	L150N
	210TC	1	L110N	L110N	L150N	L150N	L150N	L150N	L150N
	250TC	1	L110N	L110N	L150N	L150N	L150N	L150N	L150N
	280TC	1	N/A	L150N	L150N	L150N	L150N	L150N	L150N
	280TSC	1	N/A	L150N	L150N	L150N	L150N	L150N	L150N
	320TC	1	N/A	N/A	L225H	L225H	L225H	L225H	L225H
	320TSC	1	N/A	N/A	L150N	L150N	L150N	L150N	L150N
	360TC	1	N/A	N/A	N/A	L225H	L225H	L225H	L225H
	360TSC	1	N/A	N/A	L150N	L150N	L150N	L150N	L150N
	405TC	1	N/A	N/A	N/A	N/A	N/A	472174	472174
	405TSC	1	N/A	N/A	N/A	N/A	N/A	L225H	L225H
55	Coupling Element - IEC								
	IEC 90	1	L110N	N/A	N/A	N/A	N/A	N/A	N/A
	IEC 100	1	L110N	L110N	L150N	L150N	N/A	N/A	N/A
	IEC 112	1	L110N	L110N	L150N	L150N	N/A	N/A	N/A
	IEC 132	1	L110N	L110N	L150N	L150N	L150N	L150N	N/A
	IEC 160	1	L110N	L110N	L150N	L150N	L150N	L150N	L150N
	IEC 180	1	N/A	N/A	L150N	L150N	L150N	L150N	L150N
	IEC 200	1	N/A	N/A	L225H	L225H	L225H	L225H	L225H
	IEC 225	1	N/A	N/A	N/A	L225H	L225H	L225H	L225H
	IEC 225S	1	N/A	N/A	N/A	L225H	L225H	L225H	L225H
	IEC 250	1	N/A	N/A	N/A	N/A	N/A	472174	472174
	IEC 250S	1	N/A	N/A	N/A	N/A	N/A	472174	472174
	IEC 280	1	N/A	N/A	N/A	N/A	N/A	472174	472174
	IEC 280S	1	N/A	N/A	N/A	N/A	N/A	472174	472174
56	Bolt, Cover	-	032018010CR (8)	032018010CR (8)	032018010CR (10)	032018008CR (10)	032018012DR (14)	032018014DR (18)	032018016DR (16)
	Bolt, Cover	-	032130012CF (6)	032130012CF (6)	032130012CF (4)	032130012CF (4)	-	-	-
57	Lock Washer, Cover	-	034017014AF (8)	034017014AF (8)	034017014AF (10)	034017014AF (10)	034017016AF (14)	034017016AF (18)	034017016AF (16)
58	Cover	1	454270	454270	454396	454396	454522	472136	472219
59	Bevel Pinion Bearing Cup - Inner	1	403094	304809	454444	N/A	N/A	N/A	304802
	Bevel Pinion Bearing Cup - Outer	1	403094	403000	454444	403005	N/A	N/A	472260
	Bevel Pinion Bearing Assembly-Inner	1	N/A	N/A	N/A	402097	402296	472168	N/A
60	Bevel Pinion Bearing Cone - Inner	1	402283	304710	454445	N/A	N/A	N/A	402041
	Bevel Pinion Bearing Cone - Outer	1	402283	402000	454445	304717	N/A	N/A	472259
	Bevel Pinion Bearing Assembly-Outer	1	N/A	N/A	N/A	N/A	402297	472165	N/A
61	Bevel Cartridge Shim - As Required								
	.015" Shim	2	454282	472036	454442	454687	454561	472162	472254
	.007" Shim	2	454283	472037	454441	454686	454560	472161	472255
	.005" Shim	2	454284	472038	454440	454685	454559	472160	472256
62	Bevel Cartridge Bolt								
	Bolt	6	0320180008BR	0320180010BR	032018010CR	032018010CR	032018012DR	032018014DR	032018014DR
	Washer	6	034017013AF	034017013AF	034017014AF	034017014AF	034017016AF	034017016AF	034017016AF
63	Bevel Cartridge	1	454281	472031	454407	454682	454533	472124	472224

Parts for MTA2115H through MTA8407H Taper Bushed C-Face Reducers

Ref	Description	Qty	MTA2115H	MTA3203H	MTA4207H	MTA5215H	MTA6307H	MTA7315H	MTA8407H
64	Pinion, Bevel ④								
	14:1 Ratio	1	N/A	472026	454430	454679	454538	472127	472227
	15:1 Ratio	1	454285	N/A	N/A	N/A	N/A	N/A	N/A
	17:1 Ratio	1	N/A	472026	N/A	N/A	N/A	N/A	472227
	18:1 Ratio	1	454285	N/A	454430	454679	N/A	N/A	N/A
	19:1 Ratio	1	N/A	N/A	N/A	N/A	454538	472127	N/A
	21:1 Ratio	1	454285	472026	N/A	454679	N/A	N/A	N/A
	22:1 Ratio	1	N/A	N/A	454430	N/A	454538	472127	N/A
	23:1 Ratio	1	N/A	N/A	N/A	N/A	N/A	N/A	472227
	24:1 Ratio	1	N/A	N/A	N/A	N/A	454538	N/A	N/A
	25:1 Ratio	1	454285	472026	N/A	454679	N/A	N/A	N/A
	26:1 Ratio	1	N/A	N/A	454430	N/A	N/A	472127	N/A
	27:1 Ratio	1	N/A	N/A	N/A	N/A	N/A	N/A	472227
	29:1 Ratio	1	N/A	472026	N/A	454679	454538	472127	N/A
	30:1 Ratio	1	454285	N/A	454430	N/A	N/A	N/A	N/A
	31:1 Ratio	1	N/A	N/A	N/A	N/A	N/A	N/A	472227
	32:1 Ratio	1	454285	472026	N/A	N/A	N/A	N/A	N/A
	33:1 Ratio	1	N/A	N/A	N/A	N/A	N/A	472127	N/A
	34:1 Ratio	1	N/A	N/A	454430	454679	454538	N/A	472227
	35:1 Ratio	1	N/A	472026	N/A	N/A	N/A	N/A	N/A
	36:1 Ratio	1	454285	N/A	N/A	N/A	N/A	N/A	N/A
	38:1 Ratio	1	N/A	472026	N/A	N/A	N/A	472127	N/A
	39:1 Ratio	1	454285	N/A	N/A	N/A	454538	N/A	N/A
	40:1 Ratio	1	N/A	N/A	N/A	454679	N/A	N/A	472227
	41:1 Ratio	1	N/A	N/A	454430	N/A	N/A	N/A	N/A
	43:1 Ratio	1	N/A	N/A	N/A	454679	N/A	N/A	N/A
	44:1 Ratio	1	454285	472026	454430	N/A	N/A	472127	N/A
	45:1 Ratio	1	N/A	N/A	N/A	N/A	454538	N/A	N/A
	46:1 Ratio	1	N/A	N/A	N/A	N/A	N/A	N/A	472227
	47:1 Ratio	1	454285	472026	N/A	N/A	N/A	N/A	N/A
	48:1 Ratio	1	N/A	N/A	N/A	454679	N/A	N/A	N/A
	49:1 Ratio	1	N/A	N/A	454430	N/A	N/A	N/A	N/A
	50:1 Ratio	1	N/A	N/A	N/A	N/A	454540	472129	N/A
	51:1 Ratio	1	N/A	472026	N/A	454680	N/A	472127	472229
	52:1 Ratio	1	N/A	N/A	454412	N/A	454538	N/A	472227
	53:1 Ratio	1	N/A	N/A	N/A	N/A	N/A	N/A	N/A
	58:1 Ratio	1	454287	472028	N/A	N/A	N/A	472129	N/A
	59:1 Ratio	1	N/A	N/A	N/A	N/A	N/A	N/A	N/A
	60:1 Ratio	1	N/A	N/A	N/A	454680	N/A	N/A	472229
	61:1 Ratio	1	N/A	N/A	454412	N/A	N/A	N/A	N/A
	65:1 Ratio	1	N/A	N/A	N/A	454680	N/A	N/A	N/A
	66:1 Ratio	1	454287	472028	454412	N/A	N/A	N/A	N/A
	67:1 Ratio	1	N/A	N/A	N/A	N/A	454540	472129	N/A
	69:1 Ratio	1	N/A	N/A	N/A	N/A	N/A	N/A	472229
	70:1 Ratio	1	N/A	N/A	N/A	N/A	N/A	N/A	N/A
	71:1 Ratio	1	454287	472028	N/A	N/A	N/A	N/A	N/A
	72:1 Ratio	1	N/A	N/A	N/A	454680	N/A	N/A	N/A
	74:1 Ratio	1	N/A	N/A	454412	N/A	N/A	N/A	N/A
	76:1 Ratio	1	N/A	N/A	N/A	N/A	N/A	472129	N/A
	77:1 Ratio	1	454287	472028	N/A	N/A	N/A	N/A	N/A
	79:1 Ratio	1	N/A	N/A	N/A	N/A	454540	N/A	472229
65	Gear, Bevel ④								
	14:1 Ratio	1	N/A	472025	454411	454677	454537	472126	472226
	15:1 Ratio	1	454286	N/A	N/A	N/A	N/A	N/A	N/A
	17:1 Ratio	1	N/A	472025	N/A	N/A	N/A	N/A	472226
	18:1 Ratio	1	454286	N/A	454411	454677	N/A	N/A	N/A
	19:1 Ratio	1	N/A	N/A	N/A	N/A	454537	472126	N/A
	21:1 Ratio	1	454286	472025	N/A	454677	N/A	N/A	N/A
	22:1 Ratio	1	N/A	N/A	454411	N/A	454537	472126	N/A
	23:1 Ratio	1	N/A	N/A	N/A	N/A	N/A	N/A	472226
	24:1 Ratio	1	N/A	N/A	N/A	N/A	454537	N/A	N/A
	25:1 Ratio	1	454286	472025	N/A	454677	N/A	N/A	N/A

Parts for MTA2115H through MTA8407H Taper Bushed C-Face Reducers

Ref	Description	Qty	MTA2115H	MTA3203H	MTA4207H	MTA5215H	MTA6307H	MTA7315H	MTA8407H
	26:1 Ratio	1	N/A	N/A	454411	N/A	N/A	472126	N/A
	27:1 Ratio	1	N/A	N/A	N/A	N/A	N/A	N/A	472226
	29:1 Ratio	1	454286	472025	N/A	454677	454537	472126	N/A
	30:1 Ratio	1	N/A	N/A	454411	N/A	N/A	N/A	N/A
	31:1 Ratio	1	N/A	N/A	N/A	N/A	N/A	N/A	472226
	32:1 Ratio	1	454286	472025	N/A	N/A	N/A	N/A	N/A
	33:1 Ratio	1	N/A	N/A	N/A	N/A	N/A	472126	N/A
	34:1 Ratio	1	N/A	N/A	454411	454677	454537	N/A	472226
	35:1 Ratio	1	N/A	472025	N/A	N/A	N/A	N/A	N/A
	36:1 Ratio	1	454286	N/A	N/A	N/A	N/A	N/A	N/A
	38:1 Ratio	1	N/A	472025	N/A	N/A	N/A	472126	N/A
	39:1 Ratio	1	454286	N/A	N/A	N/A	454537	N/A	N/A
	40:1 Ratio	1	N/A	N/A	N/A	454677	N/A	N/A	472226
	41:1 Ratio	1	N/A	N/A	454411	N/A	N/A	N/A	N/A
	43:1 Ratio	1	N/A	N/A	N/A	454677	N/A	N/A	N/A
	44:1 Ratio	1	454286	472025	454411	N/A	N/A	472126	N/A
	45:1 Ratio	1	N/A	N/A	N/A	N/A	454537	N/A	N/A
	46:1 Ratio	1	N/A	N/A	N/A	N/A	N/A	N/A	472226
	47:1 Ratio	1	454286	472025	N/A	N/A	N/A	N/A	N/A
	48:1 Ratio	1	N/A	N/A	N/A	454677	N/A	N/A	N/A
	49:1 Ratio	1	N/A	N/A	454411	N/A	N/A	N/A	N/A
	50:1 Ratio	1	N/A	N/A	N/A	N/A	454539	472128	N/A
	51:1 Ratio	1	N/A	472025	N/A	454678	N/A	472126	472228
	52:1 Ratio	1	N/A	N/A	454413	N/A	454537	N/A	N/A
	53:1 Ratio	1	N/A	N/A	N/A	N/A	N/A	N/A	472226
	58:1 Ratio	1	454288	472027	N/A	N/A	N/A	472128	N/A
	59:1 Ratio	1	N/A	N/A	N/A	N/A	454539	N/A	N/A
	60:1 Ratio	1	N/A	N/A	N/A	454678	N/A	N/A	472228
	61:1 Ratio	1	N/A	N/A	454413	N/A	N/A	N/A	N/A
	65:1 Ratio	1	N/A	472027	N/A	454678	N/A	N/A	N/A
	66:1 Ratio	1	454288	N/A	454413	N/A	N/A	N/A	N/A
	67:1 Ratio	1	N/A	N/A	N/A	N/A	454539	472128	N/A
	69:1 Ratio	1	N/A	N/A	N/A	N/A	N/A	N/A	472228
	70:1 Ratio	1	N/A	472027	N/A	N/A	N/A	N/A	N/A
	71:1 Ratio	1	454288	N/A	N/A	N/A	N/A	N/A	N/A
	72:1 Ratio	1	N/A	N/A	N/A	454678	N/A	N/A	N/A
	74:1 Ratio	1	N/A	N/A	454413	N/A	N/A	N/A	N/A
	76:1 Ratio	1	N/A	472027	N/A	N/A	N/A	472128	N/A
	77:1 Ratio	1	454288	N/A	N/A	N/A	N/A	N/A	N/A
	79:1 Ratio	1	N/A	N/A	N/A	N/A	454539	N/A	472228
66	Bevel Pinion Shim-As Required								
	.15mm Shim	2	N/A	N/A	728403	728403	697044	797103	085034
	.30mm Shim	2	094903	094903	N/A	N/A	N/A	N/A	N/A
	.10mm Shim	2	094805	094805	728411	728411	306851	094794	725447
67	Washer, Bevel Pinion	1	093780	093780	053483	053483	190020	040141	654019
68	Retaining Ring	1	982956	982956	084851	084851	084667	084445	084511
69	Retaining Ring	1	278712	278712	278716	278716	051296	051304	051308
70	Bevel Gear Key	1	443433	454275	454443	454684	454536	472176	472247
600	Backstop Assembly	1	903102	904102	905102	906102	907102	910102	912102
100	Torque-Arm Adapter Bracket	2	902500P	903500P	904500P	905500P	906500P	909500P	909500P
	Torque-Arm Rod Kit ②	1	A73091	A73091	964268	964268	964269	965682	965682
101	③ Torque-Arm Rod End	1	A73087	A73087	A73146	A73146	A73269	964278	964278
102	③ Torque-Arm Extension	1	A73088	A73088	A73148	A73148	A73265	964280	964280
103	③ Torque-Arm Turnbuckle	1	A73089	A73089	A73147	A73147	A73266	964279	964279
104	③ RH Nut	1	407295	407295	033102022AB	033102022AB	033102024AM	033102032AM	033102032AM
105	③ LH Nut	1	A73262	A73262	A73263	A73263	A73266	965051	965051
106	Torque-Arm Bushing	1	964257	964257	964259	964259	964260	964277	964277
107	Torque-Arm Fulcrum	1	243249	243249	246249	246249	247248	272054P	272054P
108	Torque-Arm Bolt	1	032018016NR	032018016NR	032018018DR	032018018DR	032018028ER	032018032JR	032018032JR
109	Torque-Arm Lock-Washer	1	034017015AF	034017015AF	034017016AF	034017016AF	034017018AF	034017028AF	034017028AF
110	Torque-Arm Nut	1	033102015AM	033102015AM	033102016AM	033102016AM	033102018AM	033102028AM	033102028AM

Parts for MTA2115H through MTA8407H Taper Bushed C-Face Reducers

Ref	Description	Qty	MTA2115H	MTA3203H	MTA4207H	MTA5215H	MTA6307H	MTA7315H	MTA8407H
111	Torque-Arm Bolt	1	032018016ER	032018016ER	032018016ER	032018016ER	032018028ER	032018048JR	032018048JR
112	Torque-Arm Nut	1	033102018AM	033102018AM	033102018AM	033102018AM	033102018AM	033102028AM	033102028AM
113	Lock-Washer (Not Shown)	1	N/A	N/A	N/A	N/A	034017018AF	034017028AF	034017028AF
	Items 106 and 108-113 are in Kit #	1	A45700HD	A45700HD	A45702HD	A45702HD	A45705HD	-	-
200	Back-Up Plate (Incl. in Bushing Kit)	2	243308	903301	904301	905301	906301	272037	908301
201	Bushings Kit Assembly - Standard Shaft								
	4-7/16" Bore		N/A	N/A	N/A	N/A	N/A	907019	908020
	4-3/16" Bore		N/A	N/A	N/A	N/A	N/A	907021	908021
	3-15/16" Bore		N/A	N/A	N/A	N/A	N/A	907022	908022
	3-7/16" Bore		N/A	N/A	N/A	N/A	906020	907023	908023
	3-3/16" Bore		N/A	N/A	N/A	905020	906021	907024	908024
	3-0" Bore		N/A	N/A	N/A	905021	906022	907025	908025
	2-15/16" Bore		N/A	N/A	N/A	905022	906023	907026	908026
	2-7/8" Bore		N/A	N/A	N/A	905023	906024	907027	N/A
	2-11/16" Bore		N/A	N/A	904020	905024	906025	907028	N/A
	2-1/2" Bore		N/A	N/A	904021	905025	906026	907029	N/A
	2-7/16" Bore		N/A	N/A	904022	905026	906027	907030	N/A
	2-3/8" Bore		N/A	903020	904023	905027	906028	N/A	N/A
	2-1/4" Bore		N/A	903021	904024	905028	906029	N/A	N/A
	2-3/16" Bore		902020	903022	904025	905029	906030	N/A	N/A
	2-1/8" Bore		N/A	903023	904026	905030	N/A	N/A	N/A
	2-0" Bore		902022	903024	904027	905031	N/A	N/A	N/A
	1-15/16" Bore		902023	903025	904028	905032	N/A	N/A	N/A
	1-7/8" Bore		902004	903026	904029	N/A	N/A	N/A	N/A
	1-3/4" Bore		902025	903027	904030	N/A	N/A	N/A	N/A
	1-11/16" Bore		902026	903028	904031	N/A	N/A	N/A	N/A
	1-5/8" Bore		902027	903029	N/A	N/A	N/A	N/A	N/A
	1-1/2" Bore		902028	903060	N/A	N/A	N/A	N/A	N/A
	1-7/16" Bore		902029	903061	N/A	N/A	N/A	N/A	N/A
	1-3/8" Bore		902060	N/A	N/A	N/A	N/A	N/A	N/A
	1-15/16" Bore		902061	N/A	N/A	N/A	N/A	N/A	N/A
203	Retaining Ring-Included In Bushing Kit	2	421109	903304	421107	421055	906304	421098	908304
204	Cap Screw-Included In Bushing Kit	6	902306	411408	411408	411456	411456	411457	411457
205	Lock-Washer-Included In Bushing Kit	6	419011	419011	419011	419013	419013	419013	419013
400	Screw Conveyor Adapter	1	902401	903401	904401	905401	906401	907401	N/A
401	Screw Conveyor Keeper Plate	1	902402	903402	904402	905402	906402	907402	N/A
402	Screw Conveyor Wedge	1	902403	903403	904403	905403	906403	907403	N/A
403	Screw Conveyor Drive Shaft								
	1-1/2" Shaft	1	902072	903072	N/A	N/A	N/A	N/A	N/A
	1-1/2" Shaft, Stainless Steel	1	902080	903080	N/A	N/A	N/A	N/A	N/A
	2" Shaft	1	902073	903073	904073	905073	N/A	N/A	N/A
	2" Shaft, Stainless Steel	1	902081	903081	904081	905081	N/A	N/A	N/A
	2-7/16" Shaft	1	902074	903074	904074	905074	906074	907074	N/A
	2-7/16" Shaft, Stainless Steel	1	902082	903082	904082	905082	906082	907082	N/A
	3" Shaft	1	902075	903075	904075	905075	906075	907075	N/A
	3" Shaft, Stainless Steel	1	902083	903083	904083	905083	906083	907083	N/A
	3-7/16" Shaft	1	N/A	903076	904076	905076	906076	907076	N/A
	3-7/16" Shaft, Stainless Steel	1	N/A	903084	904084	905084	906084	907084	N/A
404	Retaining Bolt	1	411549	411551	411551	411551	411552	411552	N/A
405	Lock-Washer	1	419014	419016	419016	419016	419020	419020	N/A
406	Drive Shaft Key	1	902405	903405	904405	905405	906405	907405	N/A
407	Drive Shaft Washer	1	902404	903404	904404	905404	906404	907404	N/A
408	Seal	2	902411	903411	904411	905411	906411	907411	N/A
409	Bolt	4	411435	411456	411456	411483	411983	411493	N/A
410	Lock-Washer	4	419012	419013	419013	419014	419016	419016	N/A
411	Retaining Ring	1	902446	903446	904446	905446	906446	907446	N/A
412	Adjustable Packing Retainer	1	902413	903413	904413	905413	906413	907413	N/A
413	Adjustable Packing Gland Stud	2	400404	400404	400404	400404	400404	400404	N/A
414	Adjustable Packing Gland Nut	2	407202	407202	407202	407202	407202	407202	N/A
415	Sealing Rings	3	902416	903416	904416	905416	906416	907416	N/A

① Not shown on drawing.
 ② Includes parts listed immediately below marked "③".
 ③ Makes up assembly under which it is listed.
 ④ See Table 13 for actual ratio.

Table 13: Actual Ratios

Reducer Size	Actual Ratio	Output Speed @ 1750
M2H77T	76.96	22.74
M2H71T	71.18	24.59
M2H66T	66.07	26.49
M2H58T	58.29	30.02
M2H51T	51.31	34.11
M2H47T	47.45	36.88
M2H44T	44.05	39.73
M2H39T	38.86	45.03
M2H36T	35.88	48.77
M2H32T	32.15	54.43
M2H30T	29.64	59.04
M2H25T	24.87	70.37
M2H21T	21.22	82.47
M2H18T	17.68	98.98
M2H15T	14.65	119.45
M3H76T	76.02	23.02
M3H70T	70.30	24.89
M3H65T	65.26	26.82
M3H58T	57.58	30.39
M3H51T	50.68	34.53
M3H47T	46.87	37.34
M3H44T	43.51	40.22
M3H38T	38.39	45.58
M3H35T	35.44	49.38
M3H32T	31.75	55.12
M3H29T	29.28	59.77
M3H25T	24.57	71.22
M3H21T	20.96	83.49
M3H17T	17.46	100.23
M3H14T	14.47	120.94
M4H74T	73.57	23.79
M4H66T	66.17	26.45
M4H61T	61.04	28.67
M4H52T	51.72	33.84
M4H49T	49.04	35.68
M4H44T	44.11	39.67
M4H41T	40.70	43.00
M4H34T	34.48	50.75
M4H30T	30.05	58.24
M4H26T	25.57	68.44
M4H22T	21.82	80.20
M4H18T	17.89	97.82
M4H14T	14.35	121.95
M5H72T	71.98	24.31
M5H65T	64.74	27.03
M5H60T	59.73	29.30
M5H51T	50.61	34.58
M5H48T	47.99	36.47

Table 13: Actual Ratios

Reducer Size	Actual Ratio	Output Speed @ 1750
M5H43T	43.16	40.55
M5H40T	39.82	43.95
M5H34T	33.74	51.87
M5H29T	29.41	59.50
M5H25T	25.02	69.94
M5H21T	21.35	81.97
M5H18T	17.50	100.00
M5H14T	14.04	124.64
M6H79T	78.53	22.28
M6H67T	66.92	26.15
M6H59T	59.05	29.64
M6H52T	52.35	33.43
M6H50T	50.26	34.82
M6H45T	44.61	39.23
M6H39T	39.37	44.45
M6H34T	33.51	52.22
M6H29T	29.03	60.28
M6H24T	24.43	71.63
M6H22T	22.04	79.40
M6H19T	18.95	92.35
M6H14T	14.24	122.89
M7H76T	76.46	22.89
M7H67T	66.57	26.29
M7H58T	57.58	30.39
M7H51T	50.97	34.33
M7H44T	44.38	39.43
M7H38T	38.39	45.58
M7H33T	33.48	52.27
M7H29T	28.65	61.08
M7H26T	25.66	68.20
M7H22T	21.74	80.50
M7H19T	18.77	93.23
M7H14T	14.11	124.03
M8H79T	78.80	22.21
M8H69T	68.53	25.54
M8H60T	60.13	29.10
M8H53T	52.53	33.31
M8H51T	50.85	34.41
M8H46T	45.69	38.30
M8H40T	40.09	43.65
M8H34T	33.90	51.62
M8H31T	30.76	56.89
M8H27T	26.82	65.25
M8H23T	22.77	76.86
M8H17T	17.43	100.40
M8H14T	13.56	129.06

Supplemental Instructions for the Installation, Operation, and Maintenance of

ATEX Certified Motorized Torque-Arm II Shaft Mount Reducers (Zone 1) Sizes MTA2115 – MTA8407

PREFACE

The products described in this manual are manufactured by Dodge Industrial, a member of RBC Bearings Incorporated, Greenville, SC 29681 USA.

This manual (combined with MN1695) is intended to provide basic information on the safe operation and maintenance of ATEX approved Motorized Torque-Arm II shaft mount reducers. These instructions do not cover all details or variations in equipment nor provide every possible contingency or hazard to be met in connection with installation, operation, and maintenance. Should further information be desired or should particular problems arise which are not covered in the manual, the matter should be referred to your local Dodge Industrial representative.

The reducer was manufactured under the guidelines of the ATEX directive 2014/34/EU.

Torque-Arm II reducers are suitable for ATEX Category M2 for Group I and Category 2 for Group II, both gas and dust atmospheres where the ignition temperature exceeds +135°C (T4) or +275°F.

Typical reducer marking is contained on a certification plate similar to the following.

ATTENTION

The reducer is designed to operate with a surface temperature at or below 93°C (200°F). Failure to operate the reducer properly can cause this maximum surface temperature to be exceeded. If applied in a Division 1 or Zone 1 environment this excessive temperature may cause ignition of hazardous materials.

The use of supplemental cooling devices such as a shaft-mounted cooling fan or heat exchanger may be required to ensure operating temperature below 93°C (200°F) if indicated by catalog selection tables or if the reducer is operated at ambient temperatures above 27°C (80°F). Proper use of supplemental cooling, if provided, and avoidance of undesirable operating conditions is required.

ABNORMAL CONDITIONS

Operating the reducer under any of the following conditions can cause higher than normal operating temperatures:

1. Reducer load exceeding nameplate ratings
2. Ambient temperatures above nameplate rating
3. Inadequate cooling
4. Operation above maximum nameplate speed
5. Insufficient amount or improper type of lubricant

For instructions on receiving and handling, installation, operation, maintenance and repair, and service refer to manual MN1695.

MOTORIZED TORQUE-ARM II SPEED REDUCER				OIL QTY	U.S.
DODGE ®				POS. B	QTS
PART NUMBER				RATIO	
CLASS I RATING		HP AT	WEIGHT	DRAIN, FLUSH, CLEAN MAGNETIC PLUG AND REFILL EVERY 6 MONTHS, INSPECT OIL OFTEN SERVICE PER INSTRUCTION MANUAL	
			MAX INPUT RPM	PATENTED PROJECTED U.S.PATENT 5951198 OTHER PATENTS PENDING	
	Tamb -30°C to +50°C 1 M2/ 1 2 GD ckT4 SIRA 12 ATEX 6164			WARNING: Do not open when an explosive atmosphere may be present	
				S 000001	

ADDITIONAL INSTRUCTIONS FOR SAFE INSTALLATION AND USE

- Maximum input coupling misalignment:
 - NBR Material: 1 deg angular, 0.4mm (.015") parallel misalignment.
 - Hytrel Material: .5 deg angular, 0.4mm (.015") parallel misalignment.
 - Polyurethane Material: 1.3 deg angular, .0.7mm (.027") parallel misalignment.
- Do not open reducer when an explosive atmosphere may be present.
- All rotating parts should be guarded to prevent contact with foreign objects which could result in sparks and ignition.
- The reducer should be periodically inspected for proper oil level, signs of oil leakage, and dust or dirt buildup that would impede heat dissipation.
- Follow lubrication instructions and service schedule in manual MN1695. Use gear lubricant with flash point temperature 177°C (350°F) or higher.
- Increasing levels of vibration and noise could indicate the need for repair or replacement of the reducer, including replacement of bearings.
- Electrical sparks are a source of ignition. To reduce this risk, proper electrical bonding and grounding are recommended. Under standard operating conditions, the reducer is electrically bonded to the driven equipment through the output shaft connection.

Dodge Industrial, Inc.
1061 Holland Road
Simpsonville, SC 29681
+1 864 297 4800

