



**Supplemental Instructions
For the Installation, Operation of
ATEX Certified:
Sleevoil® R-Series Pillow Block
Sleevoil RTL-Series Pillow Block
Sleevoil RXT-Series Pillow Block
Sleevoil P-Series Pillow Block**

These instructions must be read thoroughly before installation or operation. This instruction manual was accurate at the time of printing. Please see dodgeindustrial.com for updated instruction manuals.

WARNING: To ensure the drive is not unexpectedly started, turn off, lock-out and tag out power source before proceeding. Failure to observe these precautions could result in bodily injury.

WARNING: All products over 25 kg (55 lbs) are noted on the shipping package. Proper lifting practices are required for these products.

Preface

The products described in this manual are manufactured by Dodge Industrial, Inc., Simpsonville, SC USA.

This manual, combined with Installation Instruction Manuals listed to the right, are intended to provide basic information on the safe operation and maintenance of ATEX approved Dodge Sleeveoil Pillow Blocks.

WARNING: Because of the possible danger to person(s) or property from accidents which may result from the improper use of products, it is important that correct procedures be followed. Products must be used in accordance with the engineering information specified in the catalog. Proper installation, maintenance and operation procedures must be observed. The instructions in the instruction manuals must be followed. Inspections should be made as necessary to assure safe operation under prevailing conditions. Proper guards and other suitable safety devices or procedures as may be desirable or as may be specified in safety codes should be provided, and are neither provided by Dodge® nor are the responsibility of Dodge. This unit and its associated equipment must be installed, adjusted and maintained by qualified personnel who are familiar with the construction and operation of all equipment in the system and the potential hazards involved. When risk to persons or property may be involved, a holding device must be an integral part of the driven equipment beyond the speed reducer output shaft.

Sleevoil Instruction Manuals

Plain PB size 1-7/16	MN3054
STL & STD PB size 1-11/16 through 3-7/16, PLWC	MN3055
SSL PB 2-15/16 through 3-7/16, PLWC	MN3056
STL & SSL PB size 3-15/16 through 8, PLXC	MN3057
STL & SSL PB size 9 through 12, XC & Plain	MN3058
STL & SSL PB size 14, Plain	MN3059
RTL Series PB size 2-15/16 through 12	MN3060 / MN3085
P-Series Pedestal	MN3061
RXT Pillow Blocks	MN3065
Auxiliary Seal & End Closure Kit	MN3063
Isolator	MN3077

These instructions do not cover all details or variations in equipment nor provide every possible contingency or hazard to be met in connection with installation, operation, and maintenance. Should further information be desired or should particular problems arise which are not covered in these manuals, the matter should be referred to your local representative.

Dodge Sleeveoil R, RTL, RXT and P series Pillow Blocks are manufactured under the guidelines of the ATEX directive 2014/34/EU.

Dodge Sleeveoil Pillow Blocks are suitable for ATEX Category 2 and M2, Group II and I, for gas and dust environments and are also suitable for ATEX Category 3 for all gas or dust environments with ignition temperatures higher than T5 = 100°C.

A name plate indicating ATEX certification will be attached to the product and will be similar to the following:

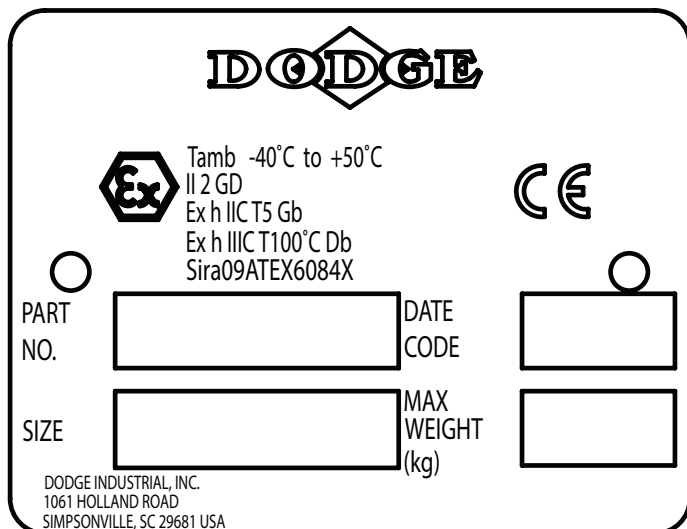

ATTENTION

These bearings, when properly installed and operated within the bearing ratings, should have a surface temperature below 180°F (82° C). Excessive temperatures, greater than 180° F (82° C) is a result of an abnormal operating condition caused by:

- Improper installation, refer to installation manual for proper procedures
- Excessive misalignment, re-align bearings and shaft
- Excessive loading, re-evaluate application and selection
- Excessive speed, re-evaluate application and selection
- Lubrication, either excessive or inadequate amounts.
- Bearing failure

If applied in a Division 1 or Zone 1 environments, this excessive temperature may cause ignition of hazardous materials. Therefore it is required that temperature monitoring devices be implemented. These sensors can operate an alarm when excessive temperatures are approached.

A suitably certified RTD must be installed on each bearing as they are relied upon for safety (reference the Selection of Suitably Certified Accessories section shown later in this document). As such, proper operation should be confirmed as part of the equipment commissioning and periodic verification checks should be included in the preventative maintenance program.

ADDITIONAL INSTRUCTIONS FOR SAFE INSTALLATION AND USE

- All rotating parts should be guarded to prevent contact with foreign objects which could result in sparks and ignition, and damage to the bearing.
- Bearings should be periodically inspected for normal wear, and for dust or dirt buildup that would impede heat dissipation.
- This equipment has a non-conducting coating and may generate an ignition-capable level of electrostatic charge under certain extreme conditions. The user shall take the necessary precautions to minimize the risk from electrostatic discharge. For example: control of the environmental humidity of the installation to minimize the generation of static electricity; protection from direct airflow that could cause a transfer of charge to the surface of the equipment; suitable electrical bonding and earth provision; cleaning of the equipment only with a damp cloth.

- Increasing levels of vibration and noise could indicate the need for inspection, repair or replacement of the bearing.
- Electrical sparks are a source of ignition. To reduce this risk, proper electrical bonding and grounding are required.
- Operating the bearing to failure may result in breakage or damage to the equipment, and could become an explosion hazard. Damaged bearing components or units must not be operated in a hazardous environment. Replace bearings per ATEX directive.
- Bearings shall be protected from vibrations from external sources.
- Oil shall be suitable for use at an operating temperature of 135°C.

To reduce the effects of bearing failure and to aid in cooling, automatic lubricating systems can be installed to ensure proper lubrication of the bearing at all times.



CERTIFICATE CONDITIONS OF USE

- A suitable RTD shall be fitted and connected to an Ignition Protection System (IPS) meeting the requirements for 'safety related devices' as defined in ESHR 1.5 of ATEX Directive 2014/34/EU. When a temperature of 82°C (180°F) is detected, the drive to the sleeveoil bearing, and supplementary heater (if installed) shall be disconnected and locked out until the IPS can be reset.**
- When fitting the RTD, Proximity Probes, Vibration Detectors, Heater or Thermoswitch, the user shall ensure that,**
 - They are suitably certified for the intended location with an upper ambient temperature rating of +82°C.**
 - They are installed in accordance with the Sleeveoil user instructions.**

HAZARDS IDENTIFIED AND PREVENTATIVE/PROTECTIVE MEASURES		
Potential Ignition Source		
Normal operation	Expected malfunction	Measures applied to prevent the source becoming effective
Frictional heating		Lubrication prevents any friction when used within design loading.
	Overloading	The instructions and individual specifications detail the maximum radial and axial loads. Condition will result in temperature increase detected by thermistor.
	Loss of lubricant	Visual level indication. Condition will result in temperature increase detected by thermistor.
	Contamination of lubricant	Sealed nature of some devices. Equipment instructions with regard to remote oil storage. Condition will result in temperature increase detected by thermistor.
	Loss of coolant	Condition will result in temperature increase detected by thermistor.
Frictional sparks		Materials of construction and use of lubrication.
	Overloading or loss of lubricant or coolant.	As 'frictional heating'.

SELECTION OF SUITABLY CERTIFIED ACCESSORIES

It is important to observe the following when selecting accessories for use with this certified product:

Equipment Type	Equipment Marking	
	Note: Typical name plate shown	Seals
Base Unit Mining and Petrochemical (Group II)	 Tamb: -40°C to +50°C Ex h IIC T5 Gb Ex h IIC T100°C Db Sira09ATEX6084X PART NO. [] DATE [] SIZE [] MAX WEIGHT [] (kg) <small>DODGE INDUSTRIAL, INC. 180 HOLLAND ROAD IMPSONVILLE, SC 29921 USA</small>	Bronze
Petrochemical Option	 Tamb: -40°C to +50°C Ex h IIC T5 Gb Ex h IIC T100°C Db Sira09ATEX6084X PART NO. [] DATE [] SIZE [] MAX WEIGHT [] (kg) <small>DODGE INDUSTRIAL, INC. 180 HOLLAND ROAD IMPSONVILLE, SC 29921 USA</small>	Aluminum
Suitably certified RTD is required; selected accessories supplied by others		

Measure RTD probe length for each bearing. Drawings are for reference purposes only.

All dimensions are in inches and are for reference purposes unless otherwise specified.

An overall probe length requirement should be calculated per RTD manufacturers instructions. Required probe length to be measured and verified prior to RTD installation.

RTL Spherical Required RTD probe length reference dimensions.

Size	B	C	D	E	F (NPSF)
2-15/16	15	2-3/16	4-7/16	5.05	1/4-18
3-7/16	15	2-3/16	4-7/16	4.88	1/4-18
3-15/16	15	2-11/32	4-15/16	5.24	1/4-18
4-7/16	12	2-3/32	5-1/2	5.17	1/4-18
4-15/16	15	2-11/16	6	6.17	1/4-18
5-7/16	15	2-29/32	6-7/8	6.63	1/2-14
6	15	3-1/8	7-1/2	7.12	1/2-14
7	15	3-13/32	8-15/16	8.08	1/2-14
8	15	3-3/4	9-3/4	9.12	1/2-14
9	15	4-13/32	10-9/16	10.25	1/2-14
10	15	4-27/32	12-1/2	11.84	1/2-14
12	15	5-11/32	13-3/4	13.55	1/2-14

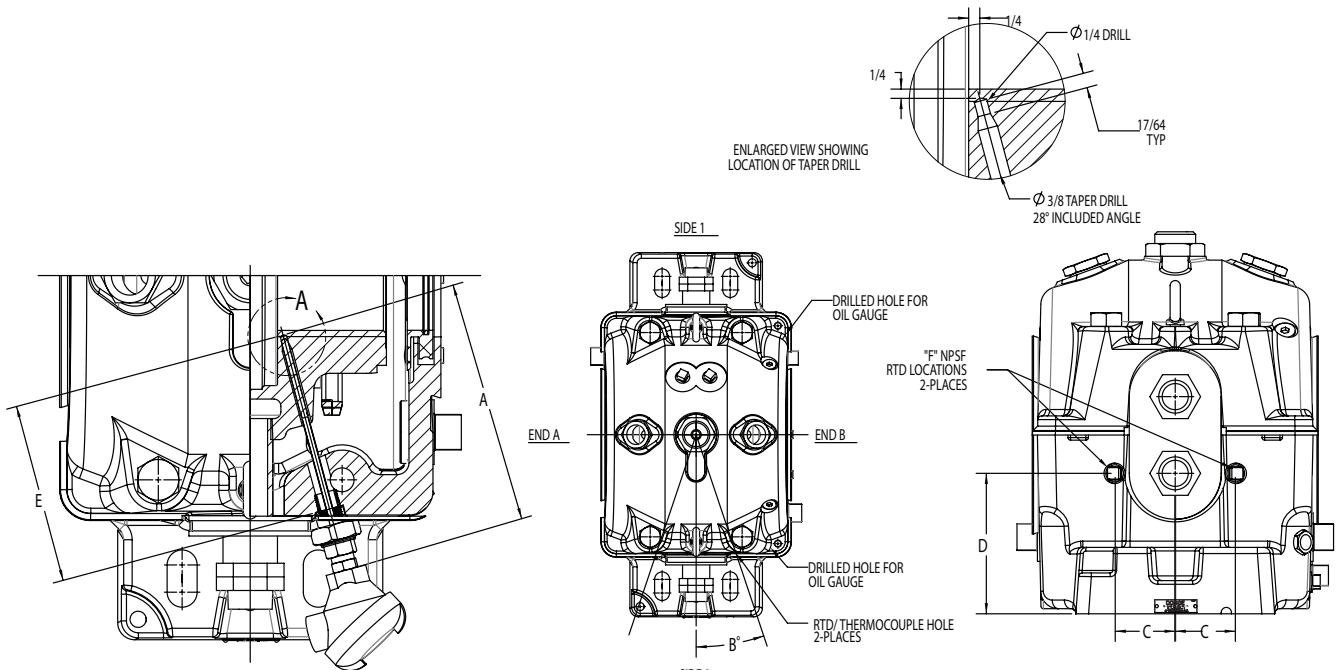

NOTES:

1. E IS LENGTH ($\pm 1/4$) FROM PROBE TIP TO BOTTOM OF SPOTFACE (NEAREST THREADS) ON HOUSING

For R-Series, P-Series or RXT RTD Probe reference dimensions, contact Engineering at 864-284-5700.

Dodge Industrial, Inc.
1061 Holland Road
Simpsonville, SC 29681
+1 864 297 4800



* 3 0 8 8 - 0 2 2 2 *