

Parts Replacement Manual For HYDROIL® TORQUE-ARM® Speed Reducers Taper Bushed For Char-Lynn®* H, S, T and 2000 Series 6B Spline Motors SIZES: HXT105 and HXT205

These instructions must be read thoroughly before installation or operation. This instruction manual was accurate at the time of printing. Please see dodgeindustrial.com for updated instruction manuals.

WARNING: To ensure the drive is not unexpectedly started, turn off and lock-out or tag power source before proceeding. Failure to observe these precautions could result in bodily injury.

WARNING: All products over 25 kg (55 lbs) are noted on the shipping package. Proper lifting practices are required for these products.

NOTE: This reducer is compatible with the Dodge ABility Smart Sensor, that can be installed in the adapter plug labeled “smart sensor”. The plug and sensor can be moved to different locations as required by mounting position.

Reducer Installation

1. Use eyebolts to lift reducer.
2. Determine the running positions of the reducer (see Fig. 1). Note that the reducer is supplied with either 4 or 7 plugs; 4 around the sides for horizontal installations and 1 on each face for vertical installations. These plugs must be arranged relative to the running positions as follows:

WARNING: Because of the possible danger to person(s) or property from accidents which may result from the improper use of products, it is important that correct procedures be followed. Products must be used in accordance with the engineering information specified in the catalog. Proper installation, maintenance and operation procedures must be observed. The instructions in the instruction manuals must be followed. Inspections should be made as necessary to assure safe operation under prevailing conditions. Proper guards and other suitable safety devices or procedures as may be desirable or as may be specified in safety codes should be provided, and are neither provided by Dodge nor are the responsibility of Dodge. This unit and its associated equipment must be installed, adjusted and maintained by qualified personnel who are familiar with the construction and operation of all equipment in the system and the potential hazards involved. When risk to persons or property may be involved, a holding device must be an integral part of the driven equipment beyond the speed reducer output shaft.

Horizontal Installations—Install the magnetic drain plug in the hole closest to the bottom of the reducer. Throw away the tape that covers the filler/ventilation plug in shipment and install plug in topmost hole. Of the 3 remaining plugs on the sides of the reducer, the lowest one is the minimum oil level plug.

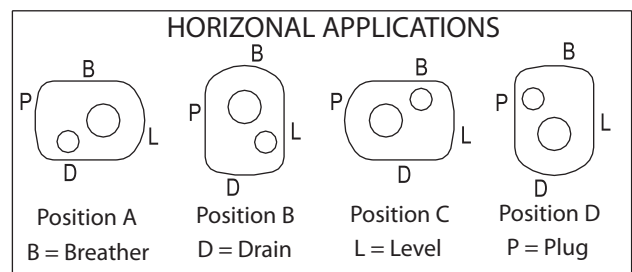

Figure 1 – Mounting Positions

The running position of the reducer in a horizontal application is not limited to the four positions shown in Figure 1. However, if running position is over 20° either way from sketches, the oil level plug cannot be safely used to check the oil level, unless during the checking the torque arm is disconnected and the reducer is swung to within 20° in positions “B” and “D” or 5° in positions “A” and “C” of the positions shown in Figure 1.

Because of the many possible positions of the reducer, it may be necessary or desirable to make special adaptations using the lubrication fitting holes furnished along with other standard pipe fittings, stand pipes and oil level gages as required.

3. Mount Taper Bushed reducer on driven shaft per instructions packed with tapered bushings.
4. Install torque arm and adapter plates using the long reducer bolts. The bolts may be shifted to any of the holes on the input end of the reducer.
5. Install torque arm fulcrum on a rigid support so that the torque arm will be approximately at right angles to the center line through the driven shaft and the torque arm anchor screw.

CAUTION: Unit is shipped without oil. Add proper amount of recommended lubricant before operating. Failure to observe these precautions could result in damage to, or destruction of, the equipment.

Table 1 – Oil Volumes

Reducer Size	Volume of Oil Required to Fill Reducer to Oil Level Plug											
	① Position A			① Position B			① Position C			① Position D		
	Fluid Ounces (Approx)	② Quarts (Approx)	Liters (Approx)	Fluid Ounces (Approx)	② Quarts (Approx)	Liters (Approx)	Fluid Ounces (Approx)	② Quarts (Approx)	Liters (Approx)	Fluid Ounces (Approx)	② Quarts (Approx)	Liters (Approx)
HXT105	20	5/8	.059	25	3/4	.71	20	5/8	.59	25	3/4	.71
HXT205	24	3/4	.71	28	7/8	.83	28	7/8	.83	28	7/8	.83

① Refer to Fig. 1 on page 2 for mounting positions

② U.S. Measure: 1 quart = 32 fluid ounces = .94646 liters.

NOTE: If reducer position is to vary from those shown in Figure 1 either more or less oil may be required. Contact Dodge Product Support.

Minimum Oil Recommendations for Average Operating Conditions

Table 2 — Lubrication Recommendations

Output RPM	ISO Grades for Ambient Temperatures of 15° to 60°														
	Reducer Size														
	1	2	3	4	5	6	7	8	9	10	12	13	14	15	
301–400	220	220	150	150	150	150	150	150	150	150	150	150	150	150	
201–300	220	220	150	150	150	150	150	150	150	150	150	150	150	150	
151–200	220	220	150	150	150	150	150	150	150	150	150	150	150	150	
126–150	220	220	220	150	150	150	150	150	150	150	150	150	150	150	
101–125	220	220	220	220	150	150	150	150	150	150	150	150	150	150	
81–100	220	220	220	220	220	150	150	150	150	150	150	150	150	150	
41–80	220	220	220	220	220	150	150	150	150	150	150	150	150	150	
11–40	220	220	220	220	220	220	220	220	220	220	150	150	150	150	
1–10	220	220	220	220	220	220	220	220	220	220	220	220	220	220	

Below – 23°F call application engineering.

20°F to -22°F use Mobil SHC 627

Above 125°F use Mobil SHC 634.

Table 3 — Lubrication Recommendations

Output RPM	ISO Grades for Ambient Temperatures of 15° to 125°														
	Reducer Size														
	1	2	3	4	5	6	7	8	9	10	12	13	14	15	
301–400	320	320	220	220	220	220	220	220	220	220	220	220	220	220	
201–300	320	320	220	220	220	220	220	220	220	220	220	220	220	220	
151–200	320	320	220	220	220	220	220	220	220	220	220	220	220	220	
126–150	320	320	320	220	220	220	220	220	220	220	220	220	220	220	
101–125	320	320	320	320	220	220	220	220	220	220	220	220	220	220	
81–100	320	320	320	320	320	220	220	220	220	220	220	220	220	220	
41–80	320	320	320	320	320	220	220	220	220	220	220	220	220	220	
11–40	320	320	320	320	320	320	320	320	320	320	220	220	220	220	
1–10	320	320	320	320	320	320	320	320	320	320	220	220	220	220	

CHAR-LYNN H, S, T AND 2000 SERIES 6B SPLINE MOTOR INSTALLATION

Consult the local Char-Lynn Motor dealer for hydraulic motor information.

Reducer Lubrication

NOTE: Because reducer is shipped without oil, it is necessary to add the proper amount of oil before running. Use a high grade petroleum base, rust and oxidation inhibited (R & O) gear oil (See Tables 1-4). Follow instructions on reducer nameplate, warning tags, and in the installation manual.

Under average industrial operating conditions, the lubricant should be changed every 2500 hours of operation or every 6 months, whichever occurs first. Drain reducer and flush with kerosene, clean magnetic drain plug and refill to proper level with new lubricant.

CAUTION: Too much oil will cause overheating and too little will result in gear failure. Check oil level regularly. Failure to observe this precaution could result in damage to or destruction of the equipment.

Under extreme operating conditions, such as rapid rise and fall of temperature, dust, dirt, chemical particles, chemical fumes, or oil sump temperatures above 200°F, the oil should be changed every 1 to 3 months depending on severity of conditions. NOTE: Pour point of lubricant selected should be at least 10°F lower than expected minimum ambient starting temperature. See the Oil Viscosity Equivalency Chart for lubricant viscosity classification equivalents.

CAUTION: Extreme pressure (EP) lubricants are not recommended for average operating conditions. Failure to observe these precautions could result in damage to, or destruction of, the equipment.

Special lubricants may be required for food and drug industry applications where contact with the product being manufactured may occur. Consult a lubrication manufacturer's representative for his recommendation.

CAUTION: Do not use EP oils or oils containing slippery additives such as graphite or molybdenum disulphide in the reducer when backstop is used. These additives will destroy sprag action. Failure to observe these precautions could result in damage to, or destruction of, the equipment

Guidelines for Torque-Arm Reducer Long-Term Storage

During periods of long storage, or when waiting for delivery or installation of other equipment, special care should be taken to protect a gear reducer to have it ready to be in the best condition when placed into service.

By taking special precautions, problems such as seal leakage and reducer failure due to the lack of lubrication, improper lubrication quantity, or contamination can be avoided. The following precautions will protect gear reducers during periods of extended storage:

Preparation

1. Drain the oil from the unit. Add a vapor phase corrosion inhibiting oil (VCI-105 oil by Daubert Chemical Co.) in accordance with Table 3.
2. Seal the unit air tight. Replace the vent plug with a standard pipe plug and wire the vent to the unit.
3. Cover the shaft extension with a waxy rust preventative compound that will keep oxygen away from the bare metal. (Non-Rust X-110 by Daubert Chemical Co.).
4. The instruction manuals and lubrication tags are paper and must be kept dry. Either remove these documents and store them inside or cover the unit with a durable waterproof cover which can keep moisture away.
5. Protect the reducer from dust, moisture, and other contaminants by storing the unit in a dry area.
6. In damp environments, the reducer should be packed inside a moisture-proof container or an envelope of polyethylene containing a desiccant material. If the reducer is to be stored outdoors, cover the entire exterior with a rust preventative.

When Placing the Reducer into Service

1. Assemble the vent plug into the proper hole.
2. Clean the shaft extensions with petroleum solvents.
3. Fill the unit to the proper oil level using a recommended lubricant. The VCI oil will not affect the new lubricant.
4. Follow the installation instructions provided in this manual.

Table 4 - Quantities of VCI #105 Oil

Case Size	Quarts or Liters
HXT105 & HXT205	1

VCI #105 & #10 are interchangeable
VCI #105 is more readily available

Parts for HXT105 6B through HXT205 6B Taper Bushed Hydroil Speed Reducers

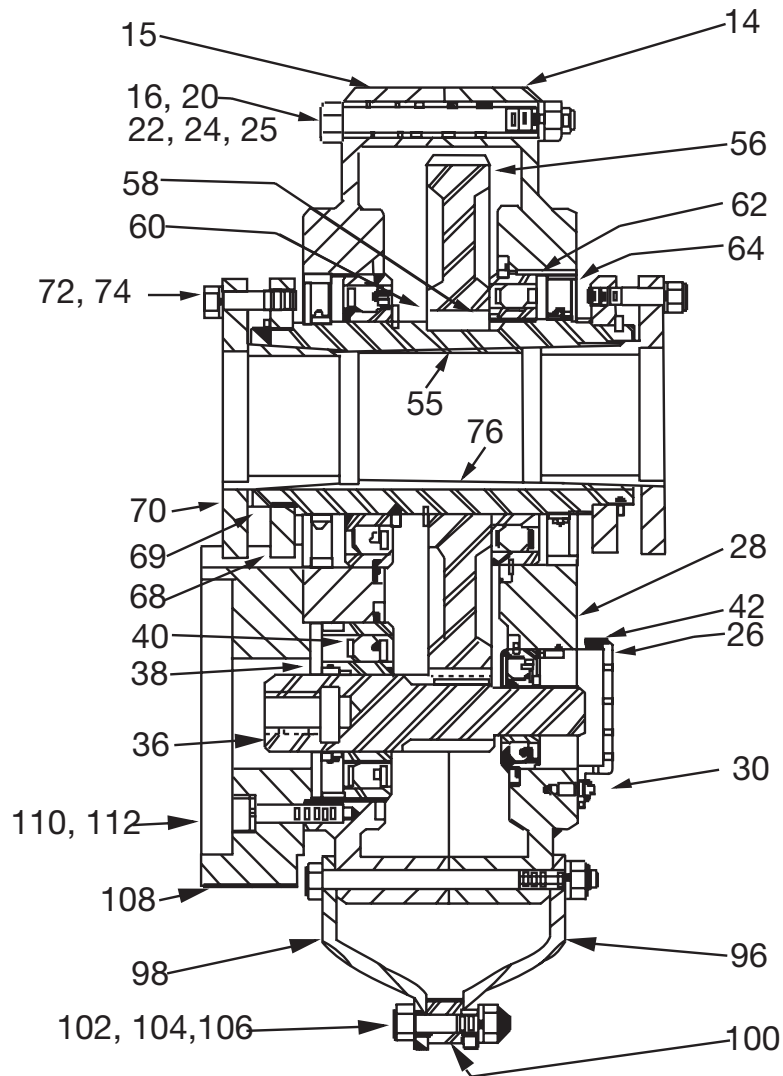

Tapered-Bushed

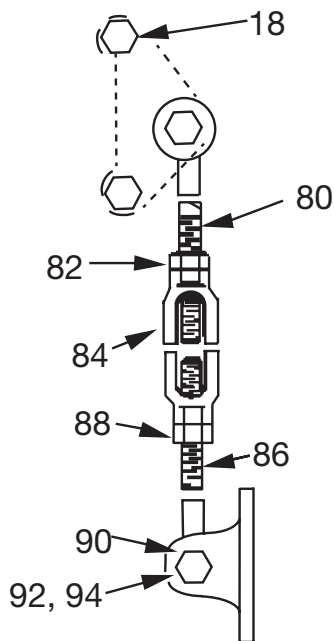

TORQUE-ARM Assembly

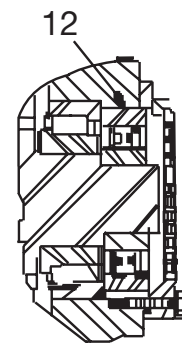

Backstop Assembly

NOTE: Please see separate instruction manual for Backstop Assembly information

Parts for HXT105 6B through HXT205 6B Taper Bushed Hydroil Speed Reducers					
Ref	Name of Part	No. Req'd.	HXT105 Part No.	HXT205 Part No.	
12	Backstop Assembly	1	242101	252101	
	HOUSING	1	241188	242196	
14					
15					
①	Air Vent	1	241237	241237	
16	Housing Bolt	④	411418	411418	
18	Adapter - Housing Bolt	2	411420	411420	
①	Washer	2	419092	419204	
20	Lockwasher	⑤	419011	419011	
22	Hex Nut	⑤	407087	407087	
24	Dowel Pin	2	420092	420091	
①	Pipe Plug	1	430031	430031	
①	Smart Sensor Adapter	1	966905	966905	
①	Magnetic Plug	1	430060	430060	
25	Washer	2	419092	419204	
26	Backstop Cover	1	242221	243221	
30	Backstop Cover Screw	4	415022	415022	
36	Input Shaft with Pinion	1	251141	252141	
	OUTPUT HUB ASSEMBLY ②				
	Taper Bushed	1	390878	392111	
55 ②	Output Hub (Taper Bushed) ③	1	241265	242134	
56 ②	③ Output Gear	1	241007	242181	
58 ②	③ Output Gear Key	1	241217	443399	
60 ②	③ Output Hub Snap Ring	2	421013	421017	
①	③ Output Hub Key (Max. Bore)	1	443037	443068	
68	Bushing Back-up Plate	2	241266	242137	
69	Retaining Ring	2	421111	421112	
70	BUSHING ② ASSEMBLY	1" Bore	1	241278
		1-1/16" Bore	1	241280
		1-1/8" Bore	1	241282	242146
		1-3/16" Bore	1	241286	242148
		1-1/4" Bore	1	241288	242150
		1-5/16" Bore	1	241290	242152
		1-3/8" Bore	1	242154
		1-7/16" Bore	1	241292	242156
		1-1/2" Bore	1	242158
		1-5/8" Bore	1	242162
		1-11/16" Bore	1	242164
		1-3/4" Bore	1	242166
		1-7/8" Bore	1
	1-15/16" Bore	1	242168	
	SEAL KIT ②	1	392127	392128	
28	③ Backstop Cover Gasket	1	242220	243220	
38	③ Input Seal	1	251089	252063	
64	③ Output Seal	2	241210	242210	
72	③ Bushing Screw	6	411405	411390	
74	③ Lockwasher	6	419010	419010	

HYDROIL Reducer Drive Size	Input Bearing Input Side		Input Bearing Adapter Side	
	DODGE Part No.	MRC Part No.	DODGE Part No.	MRC Part No.
HXT105	424137	107SKG	424012	304SG
HXT205	424078	2085G	424000	305MG

Parts for HXT105 6B through HXT205 6B Taper Bushed Hydroil Speed Reducers					
Ref	Name of Part	No. Req'd.	HXT105 Part No.	HXT205 Part No.	
76	③ Key Bushing to Shaft	1" Bore	1	443247
		1-1/16" Bore	1	443274
		1-1/8" Bore	1	443271	443281
		1-3/16" Bore	1	241308	443281
		1-1/4" Bore	1	241307	443281
		1-5/16" Bore	1	241306	443280
		1-3/8" Bore	1	241310	443280
		1-7/16" Bore	1	241305	443282
		1-1/2" Bore	1	443282
		1-5/8" Bore	1	242172
		1-11/16" Bore	1	242171
		1-3/4" Bore	1	242170
		1-7/8" Bore	1
1-15/16" Bore	1	443283		
①	③ Key, Bushing to Output Hub	1 ⑥	443272	443284	
①	③ Key, Bushing to Output Hub	1 ⑦	443273	
	TORQUE-ARM ASSEMBLY ②	1	241097	243097	
80	③ Rod End	1	241245	243245	
82	③ Hex Nut	1	407093	407095	
84	③ Turnbuckle	1	241246	243246	
86	③ Extension	1	242247	243247	
88	③ L.H. Hex Nut	1	407242	407244	
90	③ Fulcrum	1	242249	243249	
92	③ Fulcrum Screw	1	411456	411484	
94	③ Hex Nut	1	407091	407093	
	ADAPTER ASSEMBLY ②	1	259151	259152	
96	③ R.H. Adapter Plate	1	241242	242136	
98	③ L.H. Adapter Plate	1	241241	242135	
100	③ Adapter Bushing	1	242243	243243	
102	③ Adapter Bolt	1	411412	411437	
104	③ Lockwasher	1	419011	419012	
106	③ Hex Nut	1	407087	407089	
108	Motor Adapter	1	251142	252142	
110	Adapter Screw	6	417081	417081	
112	Lockwasher	6	419046	419046	
	BEARING KIT	1	389916	389911	
40	③ Input Shaft Brg.	1	424137	424078	
42	③ Input Shaft Brg. (Backstop)	1	424012	424000	
62	③ Output Hub Brg.	2	424020	424022	

- ① Not shown on drawing.
- ② Includes parts listed immediately below. Bushing assembly includes 2 bushings.
- ③ Parts marked make up the assemblies under which they are listed.
- ④ 4 required on HXT105; 5 required on HXT205.
- ⑤ 6 required on HXT105; 7 required on HXT205.
- ⑥ On size HXT105 for 3/4" through 1" bores; HXT205 for 15/16" through 1-1/2" bores.
- ⑦ On size HXT105 for 11/16" and 11/8" bores.
- ⑧ Recommended spare parts

HYDROIL Reducer Drive Size	Output Hub Bearing	
	DODGE Part No.	SKF Part No.
HXT105	424020	6011NR
HXT205	424022	6013NR

Replacement of Parts

NOTE: Using tools normally found in a maintenance department, a HYDROIL TORQUE-ARM speed reducer can be disassembled and reassembled by careful attention to the instructions following.

Cleanliness is very important to prevent the introduction of dirt into the bearings and other parts of the reducer. A tank of clean solvent, an arbor press, and equipment for heating bearings and gears should be available for shrinking these parts on shafts. Our factory is prepared to repair reducers for customers who do not have proper facilities or who for any reason desire factory service.

The oil seals are of the rubbing type, and considerable care should be used during disassembly and reassembly to avoid damage to the surface on which the seals rub.

The keyseat in the input shaft as well as any sharp edges on the output hub should be covered with tape or paper before disassembly or reassembly. Also be careful to remove any burrs or nicks on surfaces of the input shaft or output hub before disassembly or reassembly.

Ordering Parts

When ordering parts for reducer, specify reducer size number, reducer serial number, part name, part number and quantity. It is strongly recommended that when a pinion or gear is replaced, the mating gear or pinion be replaced also.

If the large gear on the output hub must be replaced, it is recommended that an output hub assembly of a gear assembled on a hub be ordered to secure undamaged surfaces on the output hub where the oil seals rub. However, if it is desired to use the old output hub, press the gear and bearing off and examine the rubbing surface under the oil seal carefully for possible scratching or other damage resulting from the pressing operation. To prevent oil leakage at the shaft oil seals, the smooth surface of the output hub must not be damaged.

If any parts must be pressed from a shaft or from the output hub, this should be done before ordering parts to make sure that none of the bearings or other parts are damaged in removal. Do not press against outer race of any bearing.

Because old shaft oil seals may be damaged in disassembly, it is advisable to order replacements for these parts.

Removing Taper Bushed Reducer From Shaft

1. Remove bushing screws.

WARNING: External loads may cause machine movement. Block machine before removing any drive train components. Failure to observe these precautions could result in bodily injury.

2. Place the screws in the threaded holes provided in the bushing flanges. Tighten the screws alternately and evenly until the bushings are free on the shaft. For ease of tightening screws, make sure screw threads and threaded holes in bushing flanges are clean.

Remove the outside bushing, the reducer and then the inboard bushing.

Disassembly

1. Position reducer on its side and remove all bolts. Gently tap the output hub and input shaft with a soft hammer (rawhide, not lead hammer) to separate the housing halves. Open housing evenly to prevent damage to parts inside.
2. Lift shaft, gear and bearing assemblies from housing.
3. Remove seals from housing.

Reassembly

1. **Output Hub Assembly:** Heat gear to 325° to 350°F to shrink onto hub. Heat bearings to 270° to 290°F to shrink onto hub. Any injury to the hub surfaces where the oil seals rub will cause leakage making it necessary to use a new hub.
2. **Input Shaft Assembly:** Shaft and pinion are integral. Press bearings on shaft. Press against inner (not outer) race of bearings.
3. Drive the two dowel pins into place in the righthand housing half. Position right half of housing (as shown in drawing) on blocks to allow clearance for protruding end of output hub.
4. Place output hub assembly in housing half. Place input shaft assembly in housing half. Tap lightly with a soft hammer (rawhide, not a lead hammer) until bearings are properly seated in the housing. Make sure that the snap rings on the O.D. of the bearings come into contact with the housing.
5. Clean housing flange surfaces on both halves, making sure not to nick or scratch flange face. Place a new bead of gasket replacer on flange face and spread evenly over entire flange leaving no bare spots. Place other housing half into position and tap with a soft hammer until housing bolts can be used or draw housing halves together. Torque housing bolts per torque values listed below:

Table 7 - Housing Bolt Torque Values	
Reducer Size	Recommended Torque
HXT105 & HXT205	360 lbs.-ins.

6. Extreme care should be used in installing seals on input shaft and output hub to avoid damage to seals due to contact with sharp edges of the keyseat in the input shaft or the retaining ring groove in the output hub. This danger of damage and consequent oil leakage can be decreased by covering the keyseat and groove with tape or paper prior to seal installation. Chamfer or deburr housing bore if end of bore is sharp or rough. Fill cavity between seal lips with grease. Seals should be pressed or tapped with a soft hammer evenly into place in the housing, applying pressure only on outer corner of seals. A slight oil leakage at the seals may be evident during initial running in, but will disappear unless seals have been damaged.
7. Install bushing back-up plate and snap rings.

OIL VISCOSITY EQUIVALENCY CHART

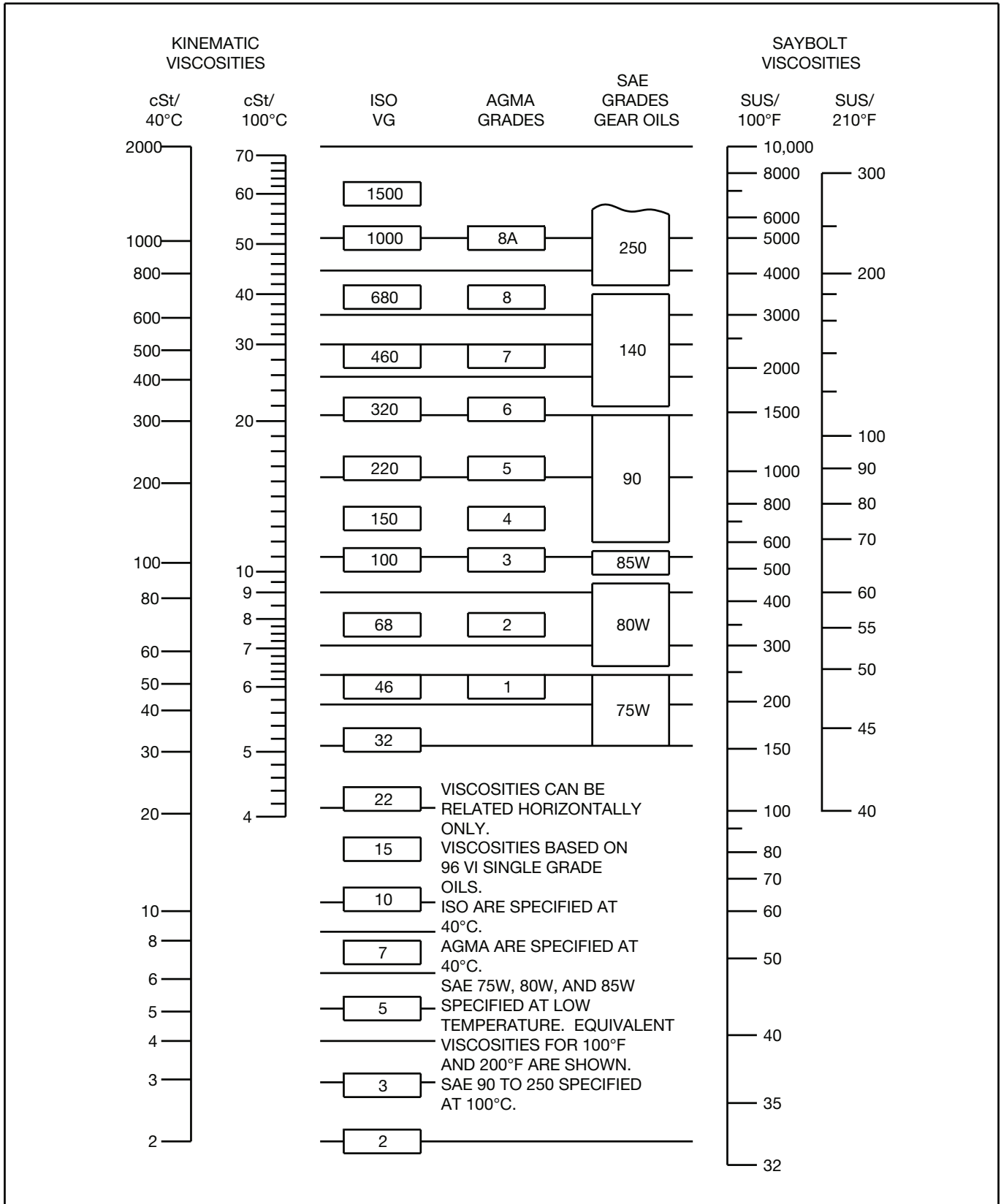

Dodge Industrial, Inc.
1061 Holland Road
Simpsonville, SC 29681
+1 864 297 4800



* 1 6 6 2 - 0 2 2 2 *