



Assembly of 10L263Y787Z1/B866140/B1220987 or other ABB or Baldor-Reliance 40 HP, NEMA 280 Frame motor to Dodge® Quantis Gearbox

These instructions must be read thoroughly before installation or operation. This instruction manual was accurate at the time of printing. Please see dodgeindustrial.com for updated instruction manuals.

WARNING: To ensure the drive is not unexpectedly started, turn off and lock-out or tag power source before proceeding. Failure to observe these precautions could result in bodily injury.

WARNING: All products over 25 kg (55 lbs) are noted on the shipping package. Proper lifting practices are required for these products.

WARNING: Because of the possible danger to person(s) or property from accidents which may result from the improper use of products, it is important that correct procedures be followed. Products must be used in accordance with the engineering information specified in the catalog. Proper installation, maintenance and operation procedures must be observed. The instructions in the instruction manuals must be followed. Inspections should be made as necessary to assure safe operation under prevailing conditions. Proper guards and other suitable safety devices or procedures as may be desirable or as may be specified in safety codes should be provided, and are neither provided by Dodge nor are the responsibility of Dodge. This unit and its associated equipment must be installed, adjusted and maintained by qualified personnel who are familiar with the construction and operation of all equipment in the system and the potential hazards involved. When risk to persons or property may be involved, a holding device must be an integral part of the driven equipment beyond the speed reducer output shaft.

NOTE: Before performing any maintenance, follow appropriate safety procedures including lock-out and tag-out. Follow safe lifting practices on heavy components.

The scope of this manual is limited to the assembly of 10L263Y787Z1/B866140/B1220987 or other Dodge or Dodge -Reliance 40 HP, NEMA 280 Frame motor to Quantis gearbox.

Step 1: Key installation in the motor shaft

This kit has been supplied with a special “stepped” key with clearance holes for M5 metric screws. Install the stepped key into the motor shaft key seat with the narrower part of the step facing the motor body and larger diameter holes facing up (refer Figure 1: Stepped key orientation when seated on motor shaft)

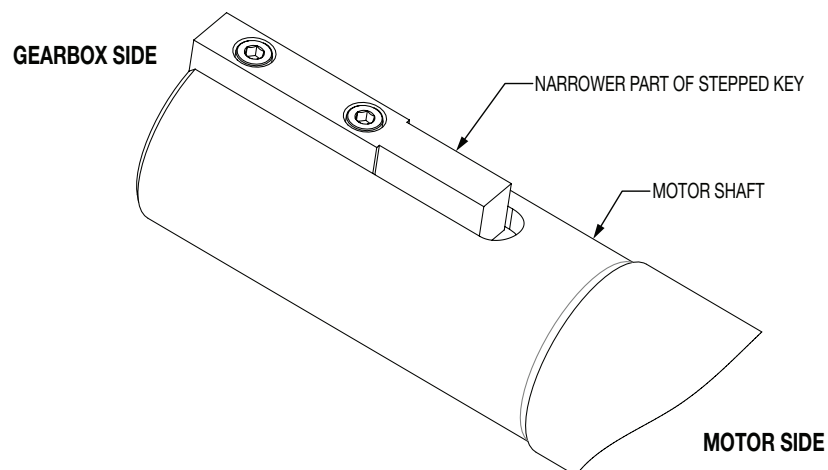

Figure 1 - Stepped key orientation when seated on motor shaft

Do NOT modify any components supplied along with the kit or reuse any existing components such as clamp collars and keys.

Do NOT install the standard motor key even if supplied with the motor. The stepped key must be installed and be correctly seated in the shaft key-seat.

In some versions of the motor, clearance holes in the stepped key will align with the tapped holes in the motor shaft and in others it will not. Other motor versions may not have tapped holes in the key-seat. This difference does not compromise functionality. However, the stepped key should NOT overhang the motor shaft regardless of whether the clearance holes align or not. Refer to Figure 2, Figure 3 and Figure 4.

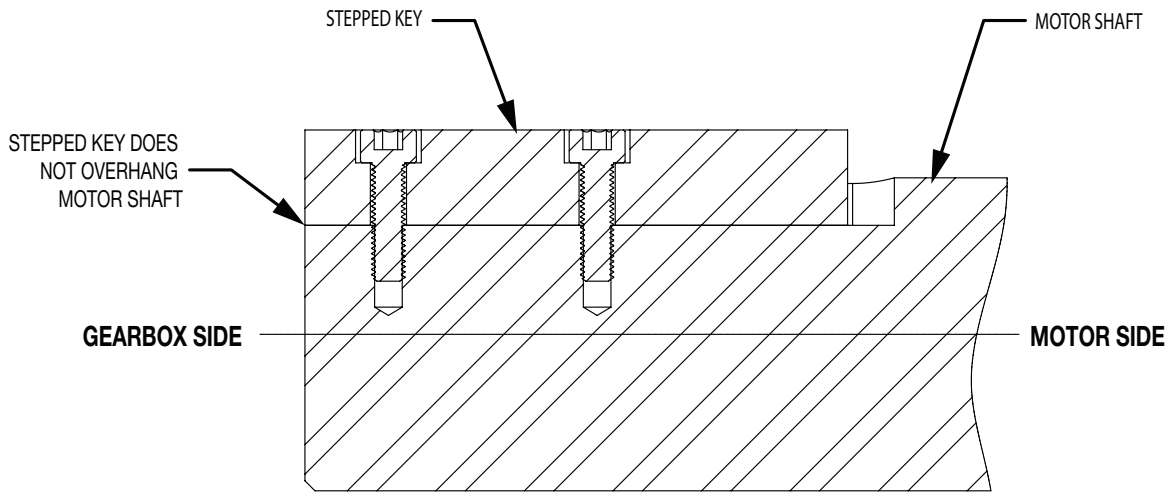

Figure 2 - CORRECT Installation method of motor stepped key if clearance holes in the key align with motor tapped holes

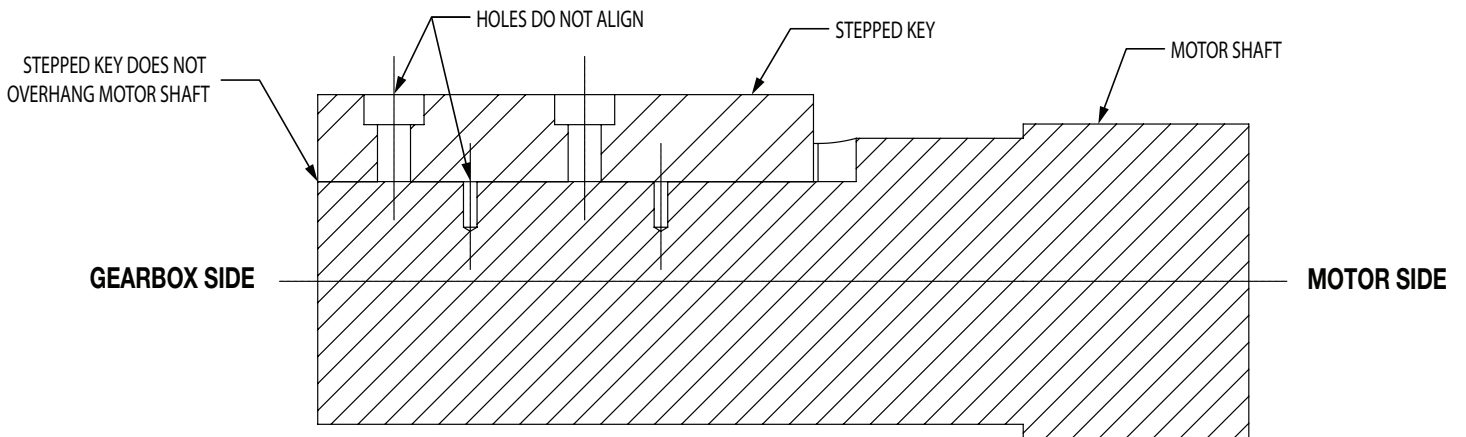

Figure 3 - CORRECT Installation method of motor stepped key if clearance holes in the key do NOT align with motor tapped holes

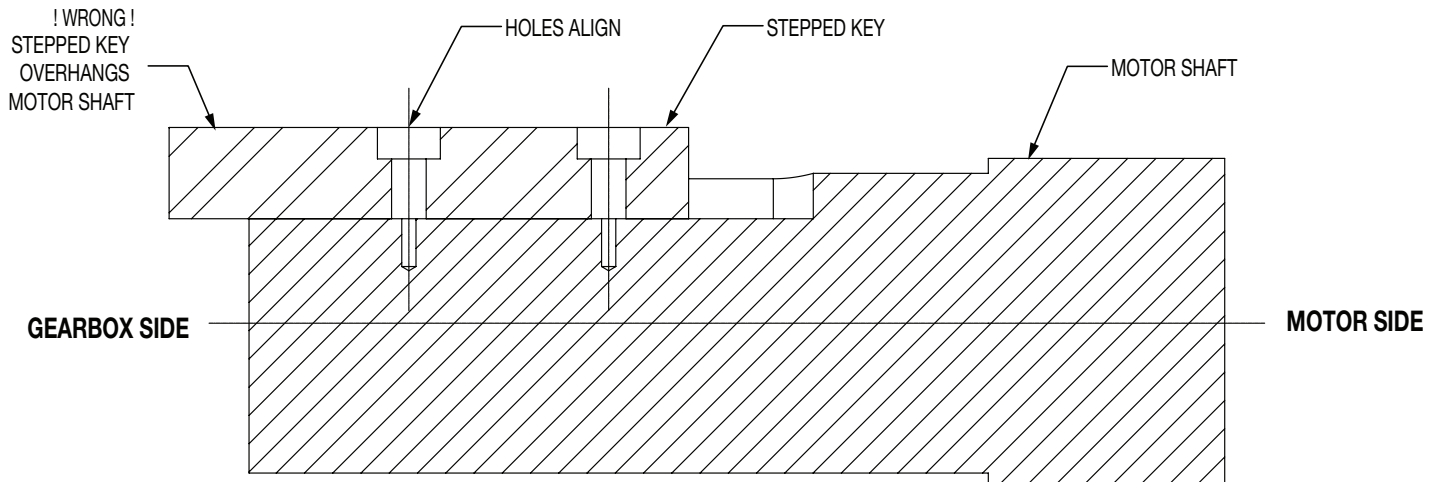

Figure 4 - !!WRONG!! Installation method of motor stepped key. Holes align but stepped key overhangs motor shaft

If the clearance holes in the stepped key align with tapped holes in the motor shaft, apply Loctite 243 on the M5 socket head cap screw threads and tighten the screws to 42 lbf-in (5 N-m) to fasten the stepped key in place.

If the clearance holes do NOT align, do not try to force M5 (or any other) screws in place.

Slide the key retainer onto the gearbox hollow input shaft. Avoid lining up the split in the key retainer with the keyway slot on the gearbox hollow input shaft. Refer to Figure 5.

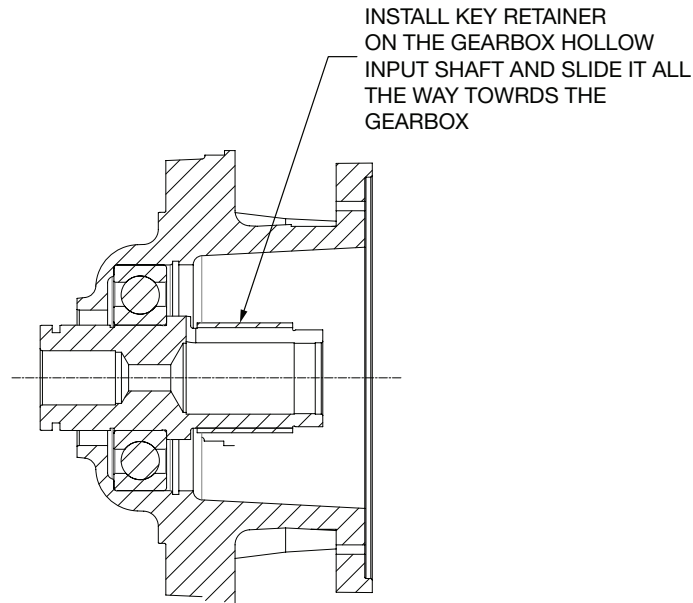

Figure 5 - Install key retainer on the gearbox hollow shaft. Avoid lining up the split in the key retainer with the keyway on the hollow shaft

Step 2: Clamp collar installation

Mark the center of the set screw hole on the clamp collar with a fine tipped marker. This indicates the center of the set screw for ease of assembly. Continue the center marks down the sides of the clamp collar as shown in Figure 6.

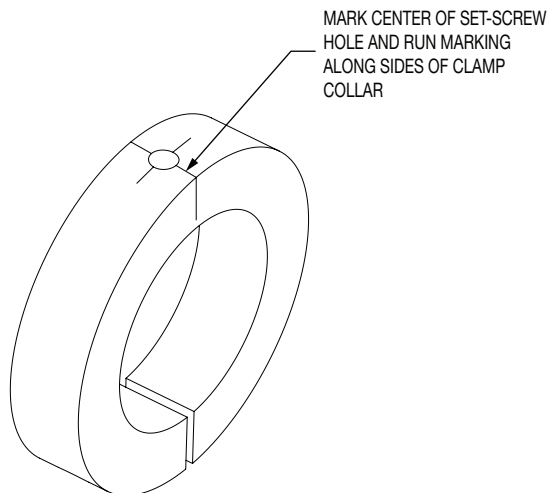

Figure 6 - Mark center of set-screw hole

Both fasteners on the clamp collar should come with pre-applied threadlocker. If not, apply Loctite 243 to the fastener threads. Slide the clamp collar onto the gearbox hollow input shaft and line up the set screw hole on the clamp collar with the key-slot on the hollow input shaft. The center marks shown in the above figure will serve as a visual aid for this alignment.

Tighten the clamp screw (socket head screw) on the clamp collar just enough to keep the clamp collar from rotating

Do NOT completely tighten the clamp screw at this time.

The set screw and clamp screw must be aligned with the access holes on the gearbox-motor adapter flange for final tightening.

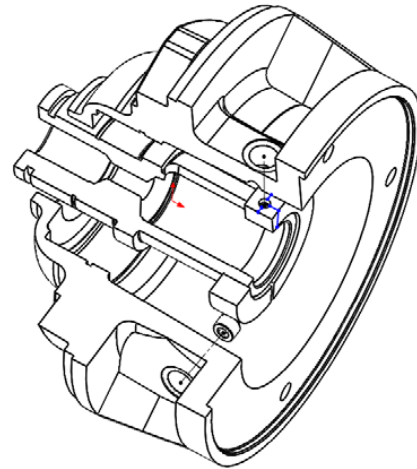

Figure 7 - Slide the clamp collar on, align set screw and clamp screw with access holes and tighten clamp screw slightly to keep clamp from rotating

Step 3: Motor installation onto the gearbox

Remove any oil/grease from the motor shaft and gearbox hollow input shaft before installing the motor.

Do NOT apply anti-seize to the motor shaft or gearbox hollow input shaft.

Install the motor onto the gearbox by positioning the motor with the stepped key aligned with the key slot on the gearbox hollow input shaft and push it into place. Insert and tighten the motor mounting screws to 55 ft-lbs (75 N-m).

Step 4: Tighten the set screw on the clamp collar

First, tighten clamp collar set screw to 220 lbf-in (25 N-m). A screw driver or similar tool can be gently wedged into the motor fan to prevent the motor shaft from rotating while tightening the clamp collar screws.

Do not tighten the clamp screw before tightening the set screw.

Step 5: Tighten the clamp screw on the clamp collar

Tighten the clamp screw with a hex socket to 50 ft-lbs (68 N-m). Use a socket wrench and extension with a short 8-mm hex bit socket to tighten the clamp screw as shown in Figure 8.

Do NOT use a “T” handle hex wrench. Use a short hex bit socket.

Remove all tools and replace the access hole plugs in the gearbox motor adapter flange.

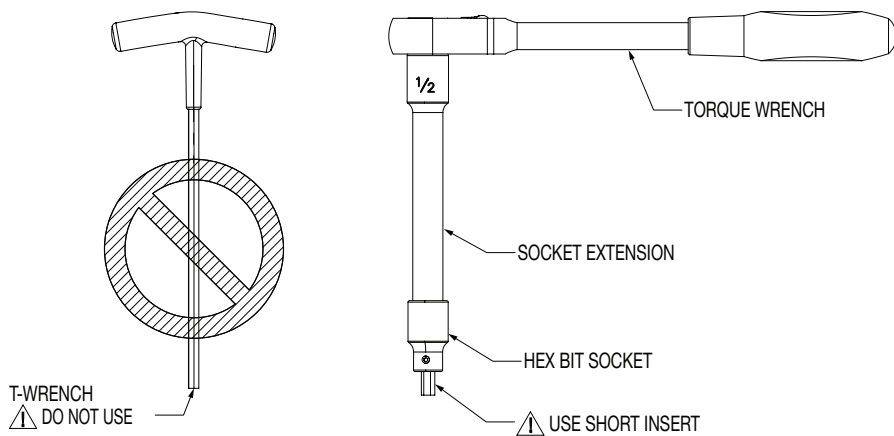

Figure 8 - Tools to be used to tighten the clamp screw

Summary

The steps above are summarized in the image below.

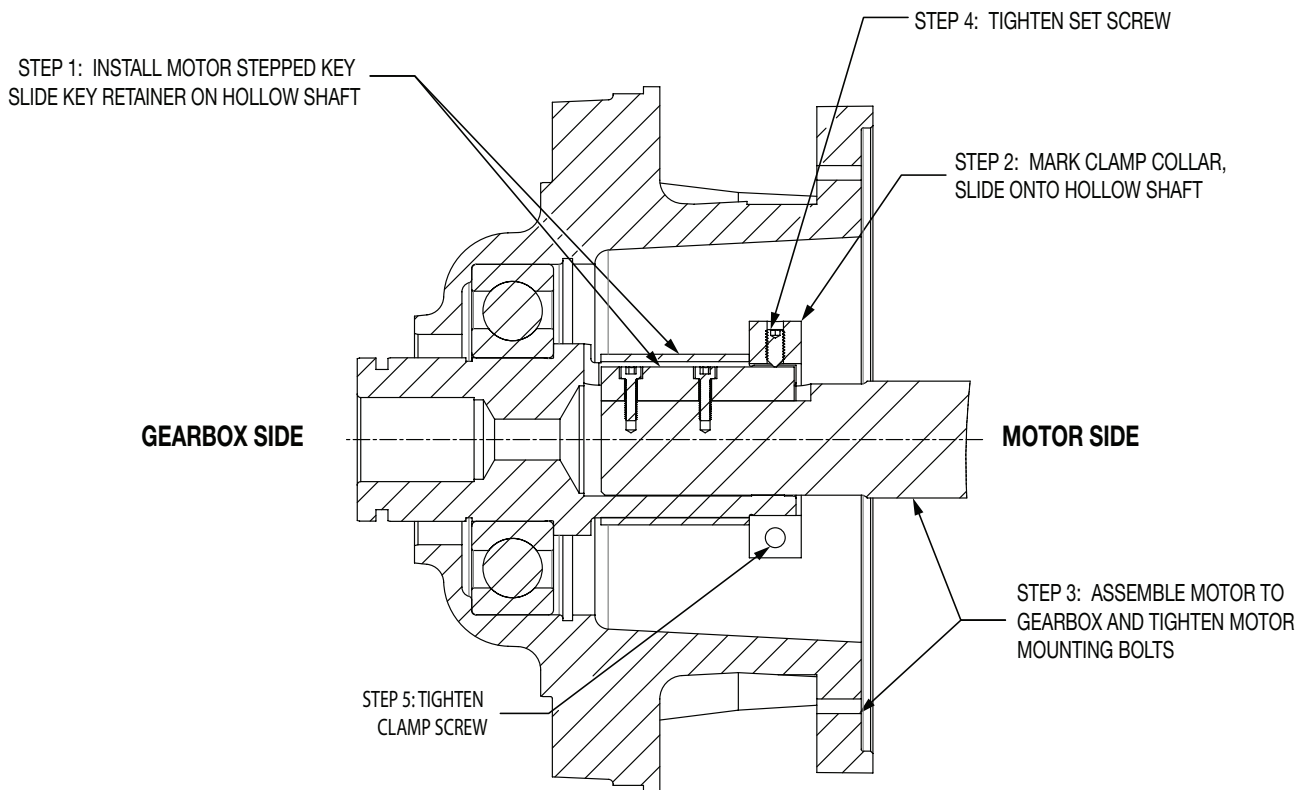

Figure 9 - Summary of installation instructions. Please review details above.

Dodge Industrial, Inc.
 1061 Holland Road
 Simpsonville, SC 29681
 +1 864 297 4800

