

Instruction Manual for Screw Conveyor Drive Auxiliary Seal Kits

For use with Dodge® TORQUE-ARM® Taper Bushed Speed Reducers

Sizes: SCXT 1 thru SCXT 8

These instructions must be read thoroughly before installation or operation. This instruction manual was accurate at the time of printing. Please see www.dodgeindustrial.com for updated instruction manuals.

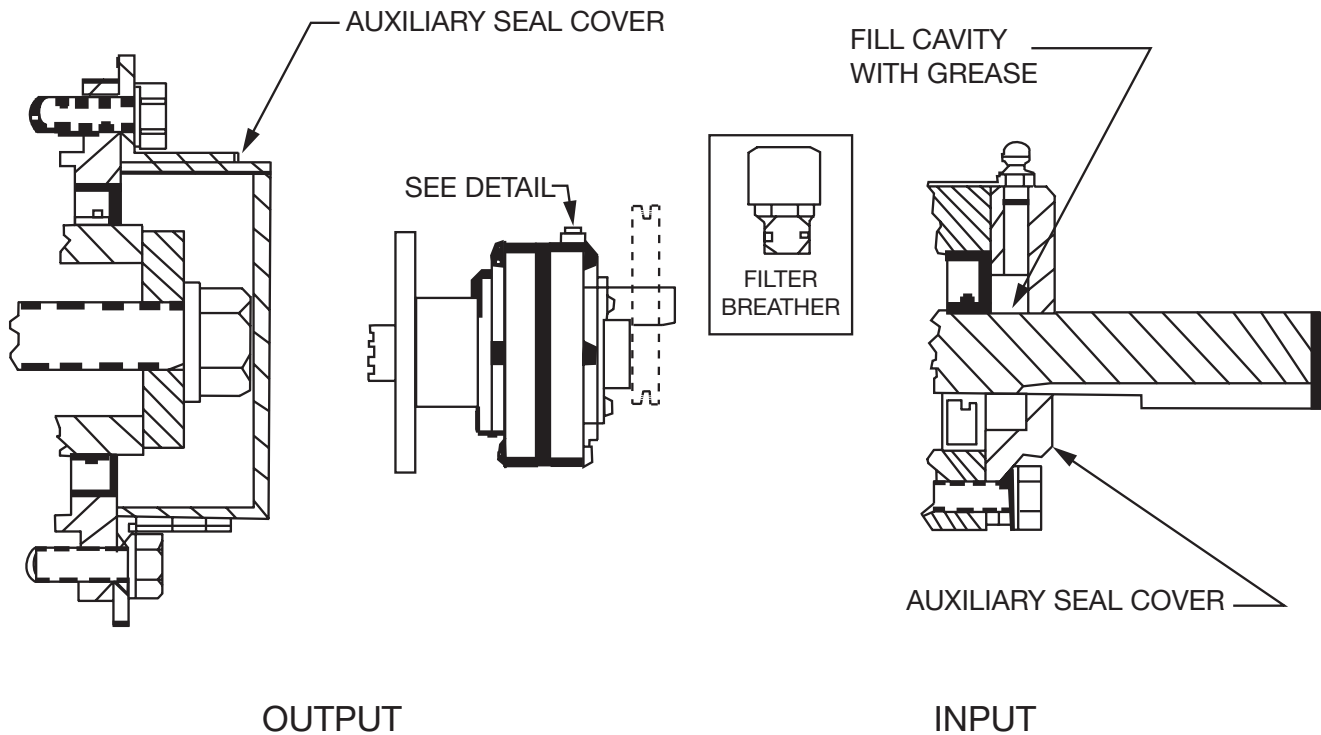

WARNING: To ensure the drive is not unexpectedly started, turn off and lock-out or tag power source before proceeding. Failure to observe these precautions could result in bodily injury.

WARNING: All products over 25 kg (55 lbs) are noted on the shipping package. Proper lifting practices are required for these products.

WARNING: Because of the possible danger to person(s) or property from accidents which may result from the improper use of products, it is important that correct procedures be followed: Products must be used in accordance with the engineering information specified in the catalog. Proper installation, maintenance and operation procedures must be observed. The instructions in the instruction manuals must be followed. Inspections should be made as necessary to assure safe operation under prevailing conditions. Proper guards and other suitable safety devices or procedures as may be desirable or as may be specified in safety codes should be provided, and are neither provided by Dodge Industrial, Inc. nor are the responsibility of Dodge Industrial, Inc. This unit and its associated equipment must be installed, adjusted and maintained by qualified personnel who are familiar with the construction and operation of all equipment in the system and the potential hazards involved. When risk to persons or property may be involved, a holding device must be an integral part of the driven equipment beyond the speed reducer output shaft.

WARNING: To insure that drive is not unexpectedly started, turn off and lock out or tag power source before proceeding. Failure to observe these precautions could result in bodily injury.

1. Locate, drill and tap three holes for the input auxiliary seal per the drawing and chart on the reverse side. For SCXT 1 and 2.

CAUTION: Do not exceed specified drill depth. Failure to observe these precautions could result in damage to or destruction of the equipment.

2. Slide rubber V-ring seal onto input shaft so that seal lip faces away from the reducer. Extreme care should be observed while installing rubber seal to avoid contact with the sharp edges of the input shaft keyseat. To avoid seal damage, cover the keyseat with tape or paper.
3. Place input shaft auxiliary seal housing in position. Install the three 3/4" long screws and lockwashers provided with the kit. Tighten screws alternately and evenly to 96 in.-lbs.

On SCXT 5A – SCXT 7 remove six bolts and on SCXT 8 remove 8 bolts from input seal carrier. Place auxiliary seal cover on top of input seal carrier. Using bolts supplied with kit, secure auxiliary cover and input seal carrier.



4. Remove two bolts from output hub seal carrier. Place output hub cover into position and reinstall bolts. Torque bolts to 360 in.-lbs. Apply RTV sealant around edge of cover for proper sealing.
5. Remove the filler/breather plug from the reducer and replace it with the filtered breather plug furnished with the auxiliary seal kit.
6. Mount the reducer on the driven shaft per the instruction sheet packaged with the reducer.

WARNING: Insure that all guards are properly installed before proceeding. Exercise extreme care to avoid contacting rotating parts. Failure to observe these precautions could result in bodily injury.

7. Fill seal cavity in the input shaft seal with a #2 consistency lithium base grease while the reducer is running. Seal cavity is full when grease shows at the purge hole, opposite the grease fitting, of the input shaft auxiliary seal housing.
8. Relubricate as often as necessary to maintain a fresh supply of grease at the seals.

Machining Dimensions for SCXT 1 Thru SCXT 4 Screw Conveyor Drive Taconite Auxiliary seal Kits

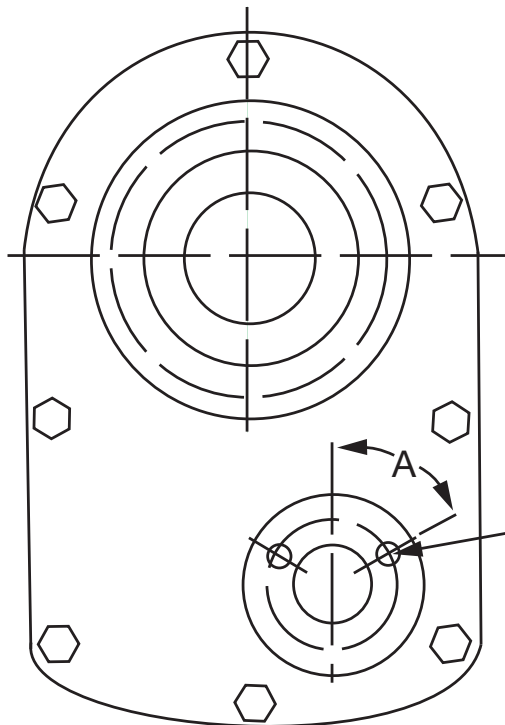

No. 7 Drill "B" Deep
1/4 - 20 N.C. Tap "C" Deep
3 Holes Equall Spaced on "D" Diam Bolt Circle
Concentric to Input Shaft

Reducer Size	A (degrees)	B ① (inches)	C (inches)	D (inches)	E (degrees)	F ① (inches)	G (inches)	H (inches)
SCXT 1	60°	3/4	1/2	2-5/8	120°	3/4	1/2	4-1/8
SCXT 2	60°	13/16	9/16	2-15/16	120°	7/8	5/8	4-3/4

① Drill depth is maximum and must not be exceeded.
Place auxiliary seal cover on input seal carrier using existing bolt holes.

Dodge Industrial, Inc.
1061 Holland Road
Simpsonville, SC 29681
+1 864 297 4800

