

# Instruction Manual For Dodge® 6B Hydroil Screw Conveyor Drive

## HSCXT3C 6B thru HSCXT7A 6B Double Reduction Hydroil Screw Conveyor Drive

### for Char-Lynn H, S, T and 2000 Series 6B Spline Motors

These instructions must be read thoroughly before installation or operation. This instruction manual was accurate at the time of printing. Please see [dodgeindustrial.com](http://dodgeindustrial.com) for updated instruction manuals.

**WARNING:** To ensure the drive is not unexpectedly started, turn off and lock-out or tag power source before proceeding. Failure to observe these precautions could result in bodily injury.

**WARNING:** All products over 25 kg (55 lbs) are noted on the shipping package. Proper lifting practices are required for these products.

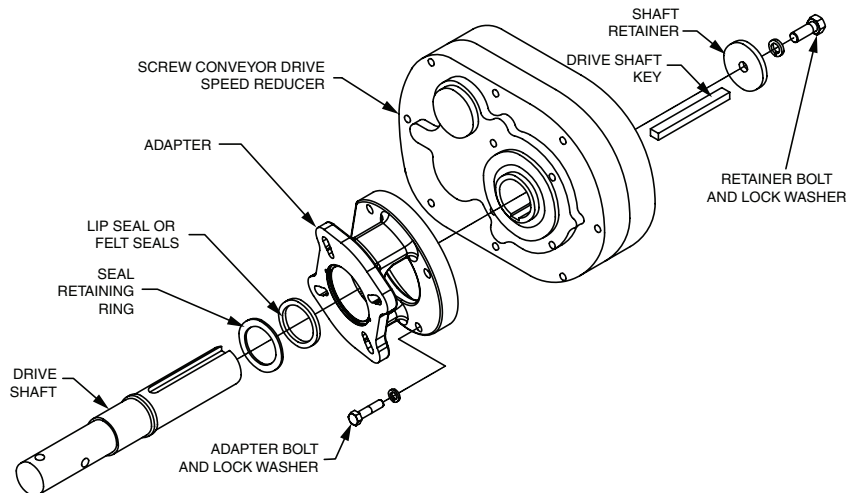

Figure 1 - Assembly

**WARNING:** Because of the possible danger to person(s) or property from accidents which may result from the improper use of products, it is important that correct procedures be followed. Products must be used in accordance with the engineering information specified in the catalog. Proper installation, maintenance and operation procedures must be observed. The instructions in the instruction manuals must be followed. Inspections should be made as necessary to assure safe operation under prevailing conditions. Proper guards and other suitable safety devices or procedures as may be desirable or as may be specified in safety codes should be provided, and are neither provided by Dodge nor are the responsibility of Dodge. This unit and its associated equipment must be installed, adjusted and maintained by qualified personnel who are familiar with the construction and operation of all equipment in the system and the potential hazards involved. When risk to persons or property may be involved, a holding device must be an integral part of the driven equipment beyond the speed reducer output shaft.

**NOTE:** This reducer is compatible with the Dodge Ability Smart Sensor that can be installed in the adapter plug labeled "smart sensor". The plug and sensor can be moved to different locations as required by mounting position.

**Note:** A Screw Conveyor Drive consists of two sub-assemblies and a drive shaft all listed below.

1. **Reducer** – Includes speed reducer, shaft retainer, retainer bolt and lockwasher.
2. **Adapter Assembly** – Includes adapter bolts, lockwashers, a lip type seal, 2 braided type seals, a seal retaining ring and drive shaft key.
3. **Drive Shaft** – Includes shaft and key in adapter assembly.

Make certain none of the parts have been damaged in shipment. Any shipping damage should be promptly reported to the carrier. Read all instructions in this manual before attempting to assemble or install the Screw Conveyor Drive. It is important that assembly be performed in the following sequence and that each step be completed before continuing to the next.

## ASSEMBLY

1. Place reducer on blocks so that it lays flat with the input shaft down
2. Position adapter on reducer output hub so that small end (end with 12 holes) rests on reducer. Select the 4 mounting holes to match the shaft used (see Fig. 1).
3. Place adapter screws and lockwashers through adapter and thread into reducer. Do not tighten.
4. Select either lip type or braided type seals and install as follows:

**Lip Type Seals** – Place seal in adapter so that spring faces out. Seal should be tapped evenly into place in the adapter with a soft hammer, applying force only on the outer corner of the seal. Fill cavity between lips of seal with grease. Install seal retainer ring by tapping with a hammer. Apply grease to adapter section of shaft (middle section). Slide shaft, keyseated end first, into adapter and through reducer.

**Note: Be extremely careful when sliding adapter section of shaft through seal to prevent seal lips from being damaged or rolled over.**

**Braided Type Seals** – Flatten both seals with a soft hammer. Place seals in adapter, one on top of the other with joints offset from each other. Lay retaining ring loosely on top of seals. Slide shaft, keyseated end first, into adapter and through reducer. Take care to clear the seals with the adapter section of the shaft. Once shaft has bottomed, seat retainer ring by simultaneously hitting the face of the ring on opposite sides of the shaft with two hammers.

5. Carefully place reducer on its side. Rotate shaft to align keyseats in shaft and output hub and install key. Install shaft retainer, lockwasher and bolt. Tighten bolt to torque specified in Table 4.
6. Lay reducer on blocks With input shaft down and tighten adapter bolts to torque specified in Table 4.
7. If waste packing is to be used, it may be installed through access hole provided in the adapter. Waste packing, not furnished with the screw conveyor drive, may be used as a separate seal option or in combination with either the lip or braided seals.

### OPTIONAL ADJUSTABLE PACKING ADAPTER ASSEMBLY

1. Place reducer on blocks so that it lays flat with the input shaft down.
2. Position adapter on reducer output hub so that small end (end with 12 holes) rests on reducer. Select the 4 mounting holes to match the shaft used. See Fig. 1.
3. Place adapter screws and lockwashers through adapter and thread into reducer. Do not tighten.
4. Install 2 screws in studs in the adapter. Use Loctite on threads. See Fig. 2.

Flatten braided seals with a soft hammer. Place seals in adapter, one on top of the other with joints offset from each other. Lay retaining ring loosely on top of seals. Slide shaft, keyseated end first, into adapter and through adjusting flange into reducer. Take care to clear the seals with the adapter section of the shaft. Once shaft has bottomed, seat retainer ring by tapping with a hammer. Install adjustable flange and secure with hex nuts provided.

5. Carefully place reducer on its side. Rotate shaft to align keyseats in shaft and output hub and install key. Install shaft retainer, lockwasher, and bolt.
6. Tighten bolts per Table 4.
7. Lay reducer on blocks with input shaft down and tighten adapter bolts per Table 4.

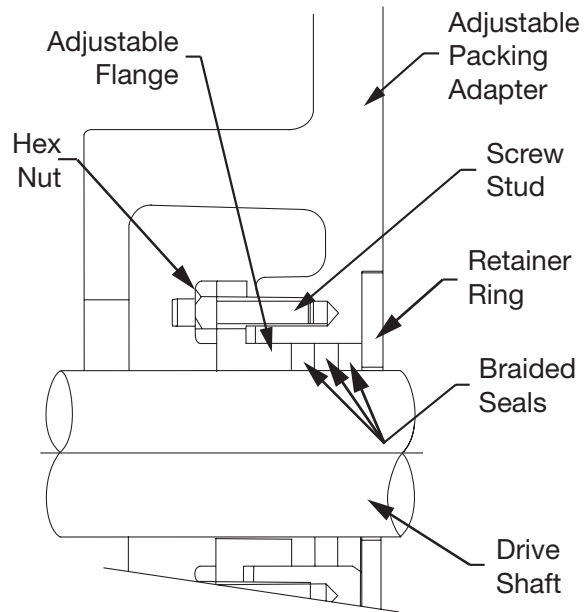

**Figure 2 - Optional Adjustable Packing Adapter**

### CHAR-LYNN H, S, T AND 2000 SERIES 6B SPLINE MOTOR INSTALLATION

Consult the local Char-Lynn Motor dealer for hydraulic motor information.

#### INSTALLATION

1. Determine the running positions of the reducer. (See Fig. 3) Note that the reducer is supplied with 7 plugs; 5 around the sides for horizontal installations and 1 on each face for vertical installations. These plugs must be arranged relative to the running positions as follows:

**Horizontal Installations** – Install the magnetic drain plug in the hole closest to the bottom of the reducer. Throw away the tape that covers the filter/ventilation plug in shipment and install plug in topmost hole. Of the 3 remaining plugs on the sides of the reducer, the lowest one is the minimum oil level plug.

**Vertical Installations** – Install the filter/ventilation plug in the hole provided in the top face of the reducer housing. Use the hole in the bottom face for the magnetic drain plug. Of the 5 remaining holes on the sides of the reducer, use a plug in the upper housing half for the minimum oil level plug.

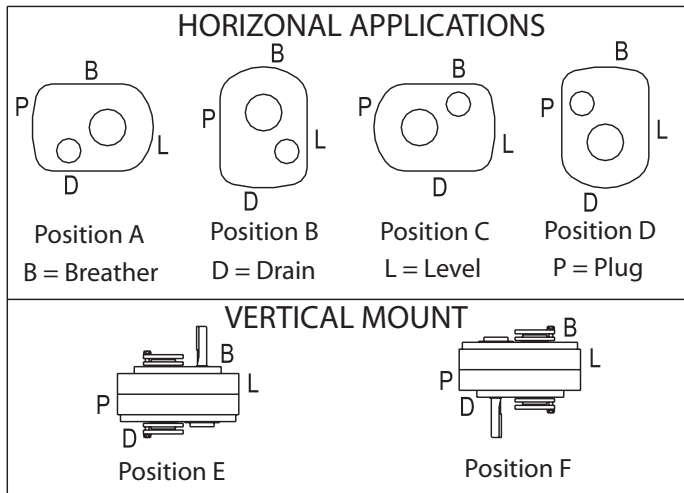

**WARNING: The user is responsible for conforming with the National Electrical Code and all other applicable electrical codes. Wiring practices, grounding, disconnects, and overcurrent protection are of particular importance. Failure to observe these precautions could result in severe bodily injury or loss of life.**

2. Because reducer is shipped without oil, it is necessary to add the proper amount before operating the drive. Use a high grade petroleum base, rust and oxidation inhibited (R & O) gear oil – see lubrication tables.
3. Retighten bolts and pipe plugs after a few days of operation. This prevents oil leakage.

**CAUTION: Unit is shipped without oil. Add proper amount of recommended lubricant before operating. Failure to observe these precautions could result in damage to, or destruction of, the equipment.**

**Figure 3 - Mounting Positions**

<b>Table 1 - Oil Volumes</b>																		
<b>Reducer Size</b>	<b>Volume of Oil to Fill Reducer to Oil Level Plug</b>																	
	<b>① Position A</b>			<b>① Position B</b>			<b>① Position C</b>			<b>① Position D</b>			<b>① Position E</b>			<b>① Position F</b>		
	<b>Fluid Oz. (app.)</b>	<b>② Qts. (app.)</b>	<b>Liters (app.)</b>	<b>Fluid Oz. (app.)</b>	<b>② Qts. (app.)</b>	<b>Liters (app.)</b>	<b>Fluid Oz. (app.)</b>	<b>② Qts. (app.)</b>	<b>Liters (app.)</b>	<b>Fluid Oz. (app.)</b>	<b>② Qts. (app.)</b>	<b>Liters (app.)</b>	<b>Fluid Oz. (app.)</b>	<b>② Qts. (app.)</b>	<b>Liters (app.)</b>	<b>Fluid Oz. (app.)</b>	<b>② Qts. (app.)</b>	<b>Liters (app.)</b>
(H)SCXT3A	48	1-1/2	1.42	48	1-1/2	1.42	24	3/4	.71	72	2-1/4	2.13	84	2-5/8	2.48	96	3	2.84
(H)SCXT4A	60	1-7/8	1.77	72	2-1/4	2.13	40	1-1/4	1.18	56	1-3/4	1.66	108	3-3/8	3.19	136	4-1/4	4.02
(H)SCXT5B	104	3-1/4	3.08	128	4	3.79	104	3-1/4	3.08	128	4	3.79	224	7	6.62	272	8-1/2	8.04
(H)SCXT6	136	4-1/4	4.00	160	6	4.70	136	4-1/4	4.00	160	5	4.70	276	8-5/8	8.20	292	9-1/8	8.06
(H)SCXT7	208	6-1/2	6.10	256	8	7.60	232	7-1/4	6.90	296	9-1/4	8.70	492	15-3/8	14.60	525	16-3/8	15.50

① Refer to Fig. 3 for mounting positions

② U.S. Measure: 1 qt. = 32 fl. oz. = .94646 liters

③ Below 15 RPM output speed, oil level must be adjusted to reach the highest oil level plug (P)

NOTE: If reducer position is to vary from those shown in Figure 3, either more or less oil may be required. Consult factory.

<b>Table 2 - Lubrication Recommendations -</b>															
<b>ISO Grades for Ambient Temperatures of 15° to 60°</b>															
<b>Output RPM</b>	<b>Reducer Size</b>														
	<b>1</b>	<b>2</b>	<b>3</b>	<b>4</b>	<b>5</b>	<b>6</b>	<b>7</b>	<b>8</b>	<b>9</b>	<b>10</b>	<b>12</b>	<b>13</b>	<b>14</b>	<b>15</b>	
301-400	220	220	150	150	150	150	150	150	150	150	150	150	150	150	
201-300	220	220	150	150	150	150	150	150	150	150	150	150	150	150	
151-200	220	220	150	150	150	150	150	150	150	150	150	150	150	150	
126-150	220	220	220	150	150	150	150	150	150	150	150	150	150	150	
101-125	220	220	220	220	150	150	150	150	150	150	150	150	150	150	
81-100	220	220	220	220	220	150	150	150	150	150	150	150	150	150	
41-80	220	220	220	220	220	150	150	150	150	150	150	150	150	150	
11-40	220	220	220	220	220	220	220	220	220	220	150	150	150	150	
1-10	220	220	220	220	220	220	220	220	220	220	220	220	220	220	

Table 3 - Lubrication Recommendations -														
ISO Grades for Ambient Temperatures of 15° to 125°														
Output RPM	Reducer Size													
	1	2	3	4	5	6	7	8	9	10	12	13	14	15
301-400	320	320	220	220	220	220	220	220	220	220	220	220	220	220
201-300	320	320	220	220	220	220	220	220	220	220	220	220	220	220
151-200	320	320	220	220	220	220	220	220	220	220	220	220	220	220
126-150	320	320	320	220	220	220	220	220	220	220	220	220	220	220
101-125	320	320	320	320	220	220	220	220	220	220	220	220	220	220
81-100	320	320	320	320	320	220	220	220	220	220	220	220	220	220
41-80	320	320	320	320	320	220	220	220	220	220	220	220	220	220
11-40	320	320	320	320	320	320	320	320	320	320	220	220	220	220
1-10	320	320	320	320	320	320	320	320	320	320	320	320	320	320

Below - 23°F call application engineer  
 20°F to 22°F use Mobil SHC627  
 Above 125°F use Mobile SHC 634

### LUBRICATION

Under average industrial operating conditions, the lubricant should be changed every 2500 hours of operation or every six months, whichever occurs first. Drain reducer and flush with kerosene, clean magnetic drain plug, and refill to proper level with new lubricant.

**CAUTION: Too much oil will cause overheating and too little will result in gear failure. Check oil level regularly.**

**CAUTION: Extreme pressure (EP) lubricants are not recommended for average operating conditions. Failure to observe these precautions could result in damage to, or destruction of, the equipment. Under extreme operating conditions, such as rapid rise and fall of temperatures, dust, dirt, chemical particles, chemical fumes, or oil sump temperatures above 200°F, the oil should be changed every 1 to 3 months, depending on the severity of the conditions.**

**CAUTION: Do not use oils containing slippery additives such as graphite or molybdenum disulphide in the reducer when backstop is used. These additives will destroy sprag action. Failure to observe these precautions could result in damage to, or destruction of, the equipment.**

### GUIDELINES FOR TORQUE-ARM REDUCER LONG-TERM STORAGE

During periods of long storage, or when waiting for delivery or installation of other equipment, special care should be taken to protect a gear reducer to have it ready to be in the best condition when placed into service.

By taking special precautions, problems such as seal leakage and reducer failure due to lack of lubrication, improper lubrication quantity, or contamination can be avoided. The following precautions will protect gear reducers during periods of extended storage:

### Preparation:

1. Drain the oil from the unit. Add a vapor phase corrosion inhibiting oil (VCI-105 oil by Daubert Chemical Co.) in accordance with Table 4.
2. Seal the unit air tight. Replace the vent plug with a standard pipe plug and wire the vent to the unit.
3. Cover the shaft extension with a waxy rust preventative, compound that will keep oxygen away from the bare metal. (Non-Rust X-110 by Daubert Chemical Co.)
4. The instruction manuals and lubrication tags are paper and must be kept dry. Either remove these documents and store them inside or cover the unit with a durable waterproof cover which can keep moisture away.
5. Protect the reducer from dust, moisture, and other contaminants by storing the unit in a dry area.
6. In damp environments, the reducer should be packed inside a moisture-proof container or an envelope of polyethylene containing a desiccant material. If the reducer is to be stored outdoors, cover the entire exterior with a rust preventative.

### When Placing the Reducer Into Service:

1. Assemble the vent plug into the proper hole.
2. Clean the shaft extensions with petroleum solvents.
3. Fill the unit to the proper oil level using a recommended lubricant. VCI oil will not affect the new lubricant.
4. Follow the installation instructions provided in this manual.

Table 4 - Quantity of VCI #105 Oil	
Case Size	Quarts or Liters
HSCXT3C-6B	.1
HSCXT4C-6B	.2
HSCXT5C-6B	.3
HSCXT6A-6B	.4
HSCXT7A-6B	.5

VCI #105 & #10 are interchangeable  
 VCI #105 is more readily available

# OIL VISCOSITY EQUIVALENCY CHART

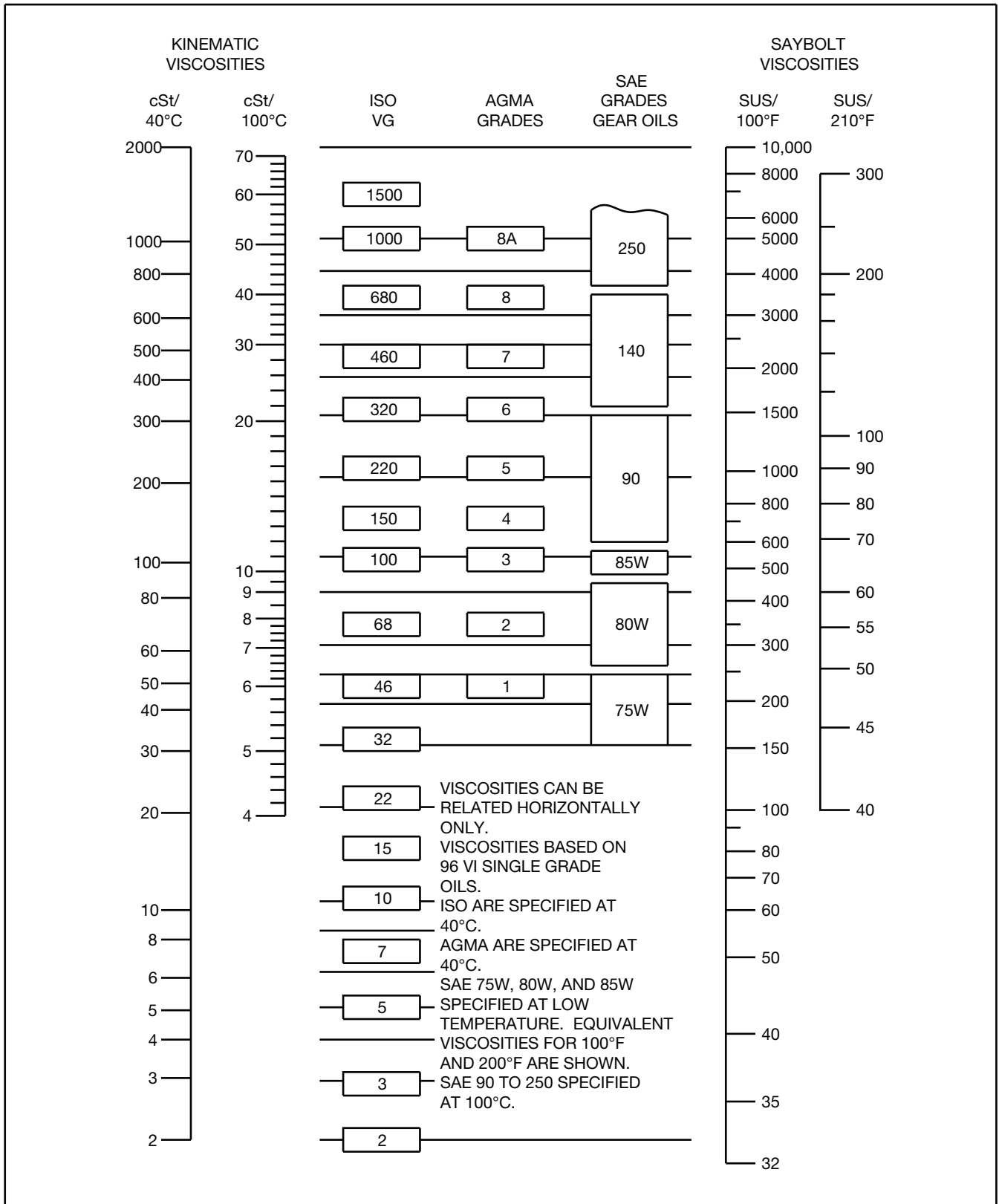

## REPLACEMENT OF PARTS

Dodge is prepared to repair Screw Conveyor Drive speed reducers for customers who do not have the proper facilities or for those who desire factory service. However, if the customer has access to an arbor press, equipment for heating and shrinking bearings and gears on shafts, and the tools normally found in a maintenance department, the Screw Conveyor Drive speed reducer can easily be disassembled and reassembled by careful attention to the following instructions.

Cleanliness is very important to prevent the introduction of dirt into the bearings and other parts of the reducer. The oil seals are of the rubbing type and considerable care should be exercised during disassembly or reassembly to avoid damage to the surfaces on which these seals rub. Any sharp edges on the input shaft or output hub should be covered with adhesive tape or paper before performing any work on the unit. Nicks and burrs on surfaces of the input shaft or output hub should be removed.

## ORDERING PARTS

When ordering parts for reducer, specify Screw Conveyor Drive size and serial number, part name, part number, and quantity.

Parts that must be pressed from shafts or output hub should be removed before ordering parts. This assures that those parts, if damaged during pressing operation, will be replaced.

It is recommended that when a pinion or gear is replaced, the mating gear or pinion be replaced also. This insures that the gear teeth will mesh properly. If the large gear on the output hub must be replaced, it is suggested that an output hub assembly, consisting of a gear assembled on an output hub, be ordered to secure an output hub with undamaged surfaces on which the oil seals rub. However, if the old output hub is to be used, carefully press the gear and bearing cones off. Thoroughly examine the area under the oil seals for scratches or any other damage resulting from the pressing operation. To prevent leakage at the oil seals, the rubbing area must be smooth.

Replacements for the old oil seals should be ordered, due to the probability of these parts being damaged during disassembly. If replacing a bearing, output hub, or a shaft, it is advisable to order a set of shims for adjustment of bearings on the shaft assembly.

If replacing a housing, a set of shims should be ordered for each shaft assembly because the adjustment of the bearings on each shaft assembly is affected.

## REMOVING SCREW CONVEYOR DRIVE FROM THE TROUGH END

Disconnect any electrical power to the drive. Drain lubricant from reducer. Uncouple drive shaft and screw. Remove nuts from trough end studs. Support drive by means of hoist and carefully pull unit away from trough end to slide drive shaft out of screw.

## DISASSEMBLY

1. Remove retainer bolt, lockwasher, and shaft retainer from drive shaft. Pull drive shaft out of reducer from adapter side. Remove adapter.
2. Position reducer on its side and remove all bolts. Gently tap the output hub and input shaft with a soft hammer (rawhide, not lead hammer) to separate the housing halves. Open housing evenly to prevent damage to the parts inside.
3. Lift shaft, gear, and bearing assemblies from housing.
4. Remove seals, seal carriers, and bearing cups from housing.
5. Clean all parts in solvent, inspect for damage, and coat with oil.

## REASSEMBLY

1. **Output Hub Assembly:** Heat gear to 325°F to 350°F to shrink onto hub. Heat bearings to 270°F to 290°F to shrink onto hub. Any injury to the hub surfaces where the oil seals rub will cause leakage, making it necessary to use a new hub.
2. **Countershaft Assembly:** Shaft and pinion are integral. Press gear and bearings on shaft. Press against inner (not outer) race of bearings.
3. **Input Shaft Assembly:** Shaft and pinion are integral. Press bearings on shaft. Press against inner (not outer) race of bearings.
4. Drive the two dowel pins into place in the right-hand housing half. Apply RTV732 sealant to carriers for R.H. side (backstop side) of reducer. Install carriers and torque bolts per Table 5.
5. Place R.H. housing half on blocks to allow for protruding end of output hub.
6. Install bearing cups in right-hand housing half, making sure they are properly seated.
7. Mesh output hub gear and small countershaft gear together and set in place in housing. Set input shaft assembly in place in the housing. Make sure bearing rollers (cones) are properly seated in their cups. Set bearing cups for left-hand housing half in place on their rollers.
8. Clean housing flange surfaces on both halves, making sure not to nick or scratch flange face. Place a 1/8" bead of RTV732 sealant on flange face (make sure RTV is placed between bolt holes and inside of flange face). Place other housing half into position and tap with a soft hammer (rawhide, not lead hammer) until housing bolts can be used to draw housing halves together. Torque housing bolts per torque values listed in Table 5.
9. Place output hub seal carrier in position without shims and install two carrier screws diametrically opposed. Torque each screw to 25 in.-lbs. Rotate the output hub to roll in the bearings and then torque each screw to 50 in.-lbs. Again turn output hub to roll in the bearings. With a feeler or taper gage, measure the gap between the housing and the carrier flange. To determine the required shim thickness, take the average of the two feeler gage readings. Remove carrier and install the required shims plus .002. Install carrier with shims and torque bolts per Table 5. Rotate hub assembly, tap lightly with rawhide mallet on end of hub, while rotating, to ensure bearings are seated. Using a dial indicator check end play of hub bearings, endplay should be .001-.003. Repeat this process as necessary to obtain proper end play. Place a 1/8" diameter bead of RTV732 sealant inside the carrier at the shim I.D. and install carrier on reducer housing. Torque carrier bolts to value shown in Table 5.
10. Adjust the countershaft bearings using the same method as in step 8 above. The axial end play should be .001" to .003".
11. Again, using the same procedure as in step 8, adjust the input shaft bearings, except the axial end play should be .002" to .004".
12. Using gaskets or RTV732 install input shaft cover and counter shaft cover to right-hand housing half. Install input and output seals. Extreme care should be used when installing seals to avoid damage due to contact with sharp edges on the input shaft or output hub. The possibility of damage and consequent oil leakage can be decreased by covering all sharp edges with tape prior to seal installation. Fill cavity between seal lips with grease. Seals should be pressed or tapped with a soft hammer evenly into place in the carrier, applying pressure only on the outer edge of the seals. A slight oil leakage at the seals may be evident during initial running, but should disappear unless seals have been damaged.
13. Install bushing backup plates and snap rings on Taper Bushed reducers or hub collars on straight bore reducers.

**Table 5 – Recommended Torque Values**

Torque-Arm Reducer Drive Size	Recommended Torque (ft.-lbs.)		
	Adapter Bolts	Housing Bolts	OP Hub Seal Carrier Bolts
HSCXT3C	70-75	45-50	15-17
HSCXT4C	145-150	45-50	27-30
HSCXT5C	145-150	68-75	27-30
HSCXT6A	145-150	68-75	27-30
HSCXT7A	145-150	135-150	45-50

Torque-Arm Reducer Drive Size	Recommended Torque (ft.-lbs.)		
	Countershaft Bearing Carrier Bolts	RH Countershaft Bearing Cover Screws	Hydroil Motor Adapter Screws
HSCXT3C	15-17	15-17	15-17
HSCXT4C	27-30	n/a	27-30
HSCXT5C	27-30	27-30	27-30
HSCXT6A	27-30	27-30	27-30
HSCXT7A	45-50	45-50	45-50

Torque-Arm Reducer Drive Size	Recommended Torque (ft.-lbs.)	
	Backstop Cover Bolts	
HSCXT3C	15-17	
HSCXT4C	27-30	
HSCXT5C	27-30	
HSCXT6A	27-30	
HSCXT7A	45-50	

**Note:** Tighten sufficient to prevent oil leaks

**Table 5 – Recommended Torque Values**

Torque-Arm Reducer Drive Size	Recommended Torque (ft.-lbs.)		
	Adapter Bolts	Housing Bolts	OP Hub Seal Carrier Bolts
HSCXT3C	70-75	45-50	15-17
HSCXT4C	145-150	45-50	27-30
HSCXT5C	145-150	68-75	27-30
HSCXT6A	145-150	68-75	27-30
HSCXT7A	145-150	135-150	45-50

Torque-Arm Reducer Drive Size	Recommended Torque (ft.-lbs.)		
	Countershaft Bearing Carrier Bolts	RH Countershaft Bearing Cover Screws	Hydroil Motor Adapter Screws
HSCXT3C	15-17	15-17	15-17
HSCXT4C	27-30	n/a	27-30
HSCXT5C	27-30	27-30	27-30
HSCXT6A	27-30	27-30	27-30
HSCXT7A	45-50	45-50	45-50

Torque-Arm Reducer Drive Size	Recommended Torque (ft.-lbs.)	
	Backstop Cover Bolts	
HSCXT3C	15-17	
HSCXT4C	27-30	
HSCXT5C	27-30	
HSCXT6A	27-30	
HSCXT7A	45-50	

**Note:** Tighten sufficient to prevent oil leaks

**PARTS FOR  
HSCXT325C 6B - HSCXT415C 6B - HSCXT 425C 6B - HSCXT525C 6B HYDROIL  
SCREW CONVEYOR DRIVE**

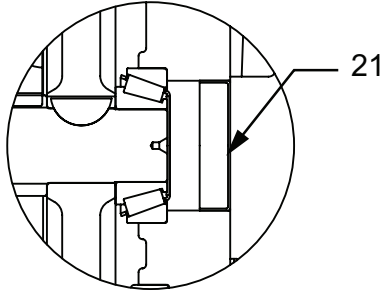
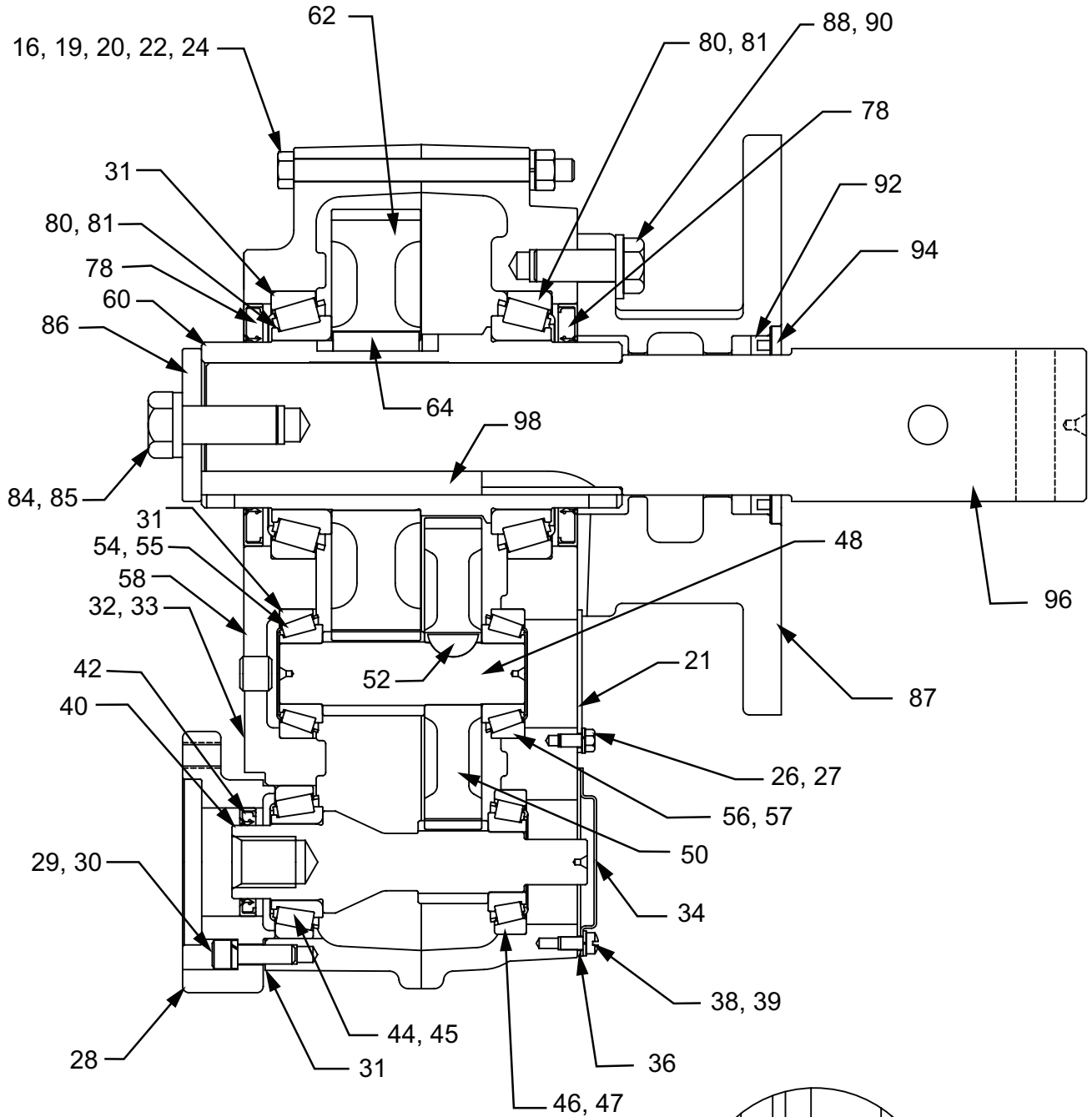

Countershaft Cover  
(Backstop Side)  
HSCXT4C - 6B Only



PARTS FOR HSCXT325C 6B - HSCXT1415C 6B - HSCXT 425C 6B - HSCXT525C 6B HYDROIL SCREW CONVEYOR DRIVE				
Reference	Name of Part	Number Required	HSCXT 3C - 6B	HSCXT 4C - 6B
	Housing Assembly	1	243538	244569
①	Air Vent	1	900287	900287
16	Housing Bolt	6	411440	411442
19	Washer	4	419094	419094
20	Lockwasher	6	419012	419012
22	Hex Nut	8	407089	407089
24⑨	Dowel Pin	2	420055	420055
①	Pipe Plug	2	430031	430031
①	Magnetic Plug	1	430060	430060
①	Smart Sensor adapter	1	966905	966905
21	Countershaft Cover Screws (Backstop Side)	4	416524	-
26	Countershaft Bearing Cover (Backstop Side)	1	243559	244495
27	Lockwasher	4	419007	-
28	Hydroil Motor Adapter	1	243467	244573
29	Adapter Screws	4 ②	417081	417108
30	Lockwasher	4 ②	419046	419047
34	Backstop Cover	1	243560	244493
38	Backstop Cover Screw	4	416524	411035
39	Lockwasher	4	419007	419009
40	6B Hydroil Input Pinion	1	-	244586
		15:1 Ratio	243498	244587
⑤	Countershaft Assembly	1	-	389707
		15:1 Ratio	389701	389708
		25:1 Ratio	243555	244590
48	Countershaft with Pinion	1	243555	244590
50	⑥ First Reduction ③ Gear	1	-	244214
		15:1 Ratio	243212	244212
		25:1 Ratio	243212	244212
52	⑥ Standard Gear Key	1	D8242	D8243
③⑩	Crescent Gear Key	1	243215	244215
	Output Hub Assembly⑤	1	389702HA	389709HA
60⑥	⑤ Output Hub	1	243557	244589
62⑥	⑤ Output Hub Gear	1	243570	244188
64⑥	⑤ Output Gear Key	1	243216	354087
31③	Complete Reducer Shim Kit	1	243800	244800
59③	SEAL KIT	1	389720	392329
82③	③ Backstop Cover Gasket	1	243561	244593
36⑥	③ Input Shaft Seal	1	A73106	A73108
42⑥	③ Output Shaft Seal	2	902286	A73109
78⑥	RTV Sealant, Tube	1	415112-80-H	
①	BEARING KIT	1	392345	329329
⑤	③ Input Shaft Bearing	1	402204	402280
44⑥	③ (Input Side)	1	403139	403027
45⑥	③ Input Shaft Bearing	1	402273	402142
46⑥	③ (Backstop Side)	1	403094	403102

PARTS FOR HSCXT325C 6B - HSCXT1415C 6B - HSCXT 425C 6B - HSCXT525C 6B HYDROIL SCREW CONVEYOR DRIVE				
Reference	Name of Part	Number Required	HSCXT 3C - 6B	HSCXT 4C - 6B
54 ⑥	③ Countershaft Bearing	1	402273	402000
55 ⑥	③ (Input Side)	1	403094	403000
56 ⑥	③ CounterShaft Bearing	1	402273	402000
57 ⑥	③ (Backstop Side)	1	403094	403000
80 ⑥	③ Output Hub Bearing	2	402272	402288
81 ⑥	③ Output Hub Bearing	2	403127	403163
84	Retainer Bolt	1	411551	411551
85	Lockwasher	1	034017020AB	
86	Shaft Retainer	1	353053	354088
⑤	Adapter Assembly	1	353047	354121
87 ⑥ ⑦	Adapter	1	356164	356150
88 ⑥	Bolt	4	411456	411483
90 ⑥	Lockwasher	4	419013	034017018AB
93 ⑥	Lip Seal	1	353085	354115
94 ⑥	Seal Retaining Ring	1	353054	354089
98 ⑥	Key	1	443089	443114
⑧⑤	Adjustable Packing Kit	1	356303	356304
①⑥	Adjustable Packing Retainer	1	356166	356152
①⑥	Stud	2	400404	400404
①⑥	Hex Nut	2	407202	407202
①⑥	Braided Seal	3	427658	427664
96	Drive Shaft	1	243562	244594
		1 1/2" Diameter	243563	244595
		2" Diameter	243564	244596
		2 7/16" Diameter	243565	244597
		3" Diameter	-	244598
		3 7/16" Diameter	-	244598

NOTES:

- ① Not shown on drawing.
  - ② 5 required on HSCXT525C - 6B.
  - ③ Recommended spare parts
  - ④ If replacing a bearing, output hub, or a shaft, it is advisable to order a set of shims for adjustment of bearings on the shaft assembly. If replacing a housing, a set of shims should be ordered for each shaft assembly because the adjustment of the bearings on each shaft assembly is affected.
  - ⑤ Includes parts listed immediately below marked
  - ⑥ Makes up assembly under which listed
  - ⑦ Must buy complete assembly
  - ⑧ Must have adapter assembly to use packing kit
  - ⑨ Included with Housing Assembly
  - ⑩ Key was changed from crescent shaped key to standard key in April 2006
- For HSCXT3C-6B countershaft built before 4/06 use 243215, after 4/06 use D8242  
For HSCXT4C-6B countershaft built before 4/06 use 244215, after 4/06 use D8243  
For HSCXT5C-6B countershaft built before 4/06 use 244215, after 4/06 use D8243

**PARTS FOR HSCXT625A - 6B & HSCXT725A - 6B**

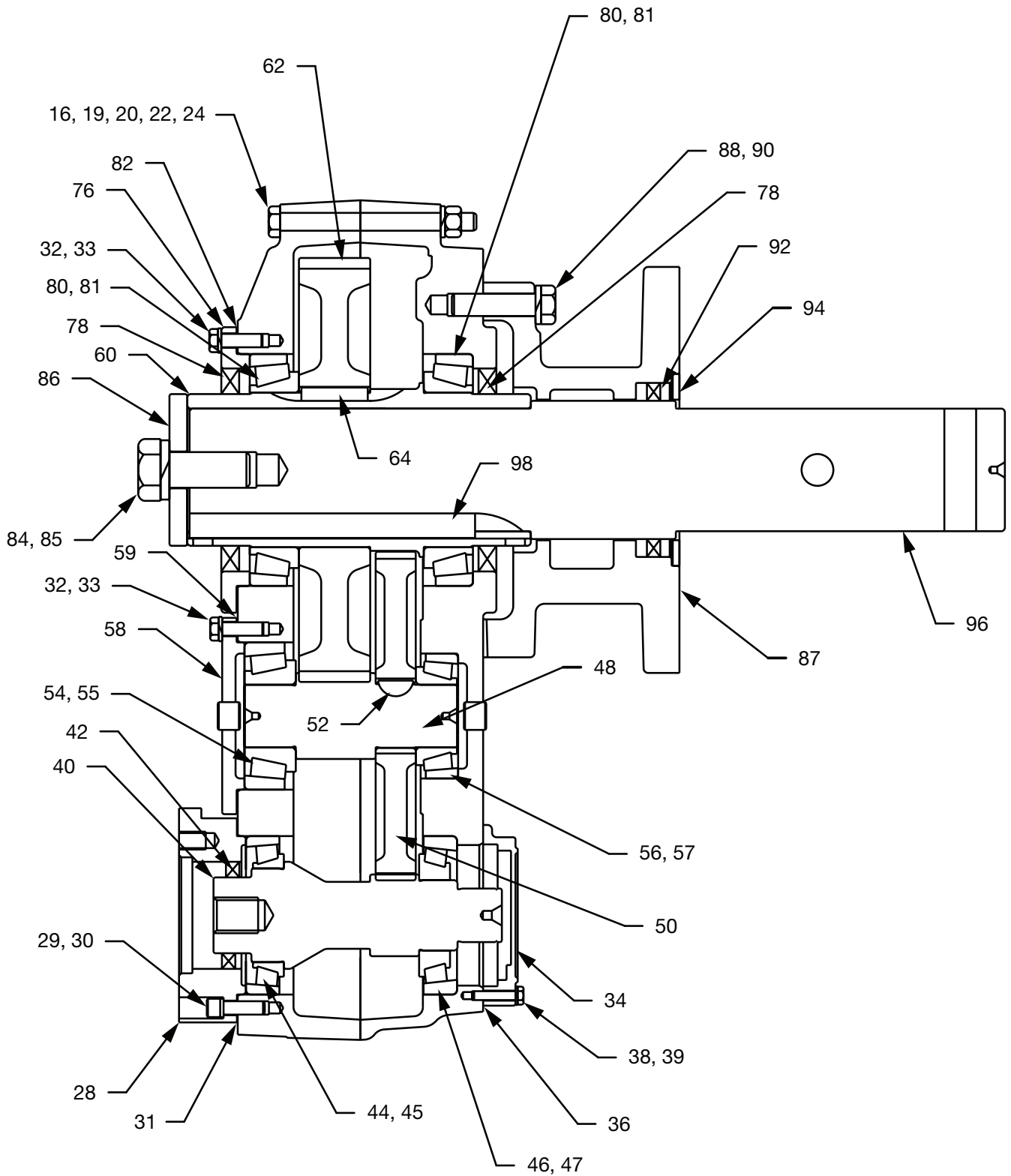

PARTS FOR HSCXT525 - 6B & HSCXT725 - 6B					
Ref.	Name of Part	Number Required	HSCXT5C - 6B	HSCXT6A-6B	HSCXT7A - 6B
	Housing Assembly	1	245589	356297	356280
③	Air Vent	1	904287	904287	904287
16	Housing Bolt	8	411464	411466	411498
20	Lockwasher	8	419096	419013	034017020AB
③	Washer	2	419013	419096	419082
22	Hex Nut	8	407091	407091	407095
24	Dowel Pin	2	420110	420112	420128
③	Oil Plug	5	430033	430033	430035
①	Smart Sensor Adapter	1	966907	966906	966906
③	Magnetic Plug	1	430062	430062	430064
28	Hydroil Motor Adapter	1	245643	246522	247522
29	Adapter Screws	6	417108	417108	417141
30	Lockwasher	6	419047	419047	419048
32	Carrier and Cover Screws	⑧	411407	032018010CJ	411433
33	Lockwasher	⑧	419011	419011	419012
34	Backstop Cover	1	245547	246221	247221
38	Backstop Cover Screw	6	411406	411404	411402
39	Lockwasher	6	419009	419009	419009
40	④ 6B Hydroil Input Pinion	25: 1 Ratio	-	246521	247521
①	Countershaft Assembly		245641		
48②	④ Countershaft with Pinion	25:1 Ratio	389715	391186	391197
50②	④ First Reduction	25:1 Ratio	244596	246294	247002
52②	④ Standard Gear Key	1	245212	246293	247005
⑦	Crescent Gear Key	1	D8243	D8244	301193
58	Countershaft Bearing Cover	(Input Side)	244215	245218	247218
			245594KIT	246185	247194
①	Output Hub Assembly	1	389716HA	390988	390990
60②	④ Output Hub	1	245591	246338	247338
62②	④ Output Gear	1	245186	246295	247215
64②	⑥ Output Gear Key	2	391026	245217	245217
31					
59	④ Complete Shim Kit	1	389725	246166	247138
82					
76	Output Hub Seal Carrier (Input Side)	1	245592	246187	247315
84	Retainer Bolt	1	411551	411552	411552
85	Lockwasher	1	034017020AB	419020	419020
86	Shaft Retainer	1	355065	356047	356191
①	Adapter Assembly	1	355072	356055	356187
87②	⑤ Adapter Bolt	1	356159	356155	356193
88②	⑤ Adapter Bolt	4	411483	032018020EJ	411496
③	RTV Sealsant Tube	1		415112-80-H	
90②	Lockwasher	4	034017020AB	419014	034017020AB
92②	Lip Seal	1	355067	355054	355054
90②	Seal Retaining Ring	1	355066	356054	356054
98②	Key	1	443239	443288	443289
⑥①	Adjustable Adapter Assembly	1	356305	356306	356306
③②	Adjustable Packing Retainer	1	356161	356157	356157
③②	Stud	2	400404	400404	400404
③②	Hex Nut	2	407202	407202	407202
③②	Braided Seal	3	427674	427687	427687

PARTS FOR HSCXT525 - 6B & HSCXT725 - 6B					
Ref.	Name of Part	Number Required	HSCXT5C - 6B	HSCXT6A-6B	HSCXT7A - 6B
96	Drive Shaft	1	-	356040	356180
			1-1/2 Diameter	356041	356181
			2" Diameter	356042	356182
			2-7/16" Diameter	356043	356183
			3" Diameter	356044	356184
①	SEAL KIT	1	389722	389720	392329
36④	② Backstop Cover Gasket	1	245220	246220	246220
42④	② Input Shaft Seal	1	234277	246524	246524
78④	② Output Hub Seal	1	904286	905286	247310
①	Bearing Kit	1	392334	392337	392339
44②	④ Input Shaft Bearing	1	402144	402196	402150
45②	④ (Input Side)	1	403104	403091	403106
46②	④ I/P Shaft Bearing	1	402266	402197	402088
47②	④ (Backstop Side)	1	403073	403091	403047
54②	④ Countershaft Bearing	1	402203	402054	402256
55②	④ (Input Side)	1	403027	403159	403053
56②	④ Countershaft Bearing	1	402203	402052	402256
57②	④ (Backstop Side)	1	403027	403142	403053
80②	④ Output Hub	2	402193	402050	402058
81②	④ Bearing	2	403016	403140	403111

NOTES:

- ① Includes parts listed below marked with note 2
  - ② Makes up assemblies under which they are listed
  - ③ Not shown on drawing
  - ④ Recommended spare parts
  - ⑤ Must buy complete assembly
  - ⑥ Must have adapter assembly to use packing kit
  - ⑦ Key was changed from crescent shaped to standard key
- For original HSCXT16-6B countershaft, use 245218, for current style use D8244  
For original HSCXT7-6B countershaft, use 247218, for current style use 301193  
Current style standard key sold with the countershaft assembly
- ⑧ 18 required on HSCXT625-6B; 20 required on HSCXT7-6B

**Dodge Industrial, Inc.**  
1061 Holland Road  
Simpsonville, SC 29681  
+1 864 297 4800



\* 1 6 7 6 - 0 2 2 2 \*