

Quantis Torque Arm Installation Instructions

These instructions must be read thoroughly before installation or operation. This instruction manual was accurate at the time of printing. Please see dodgeindustrial.com for updated instruction manuals.

WARNING: To ensure the drive is not unexpectedly started, turn off and lock-out or tag power source before proceeding. Failure to observe these precautions could result in bodily injury.

WARNING: All products over 25 kg (55 lbs) are noted on the shipping package. Proper lifting practices are required for these products.

WARNING: Follow appropriate lock-out / tag-out procedures to immobilize the drive motor and driven equipment.

WARNING: Only qualified, trained, maintenance personnel should install the torque arm and reducer onto the driven equipment.

WARNING: Provide a proper support for the reducer while mounting it on the driven shaft.

WARNING: Because of the possible danger to person(s) or property from accidents which may result from the improper use of products, it is important that correct procedures be followed. Products must be used in accordance with the engineering information specified in the catalog. Proper installation, maintenance and operation procedures must be observed. The instructions in the instruction manuals must be followed. Inspections should be made as necessary to assure safe operation under prevailing conditions. Proper guards and other suitable safety devices or procedures as may be desirable or as may be specified in safety codes should be provided, and are neither provided by Dodge nor are the responsibility of Dodge. This unit and its associated equipment must be installed, adjusted and maintained by qualified personnel who are familiar with the construction and operation of all equipment in the system and the potential hazards involved. When risk to persons or property may be involved, a holding device must be an integral part of the driven equipment beyond the speed reducer output shaft.

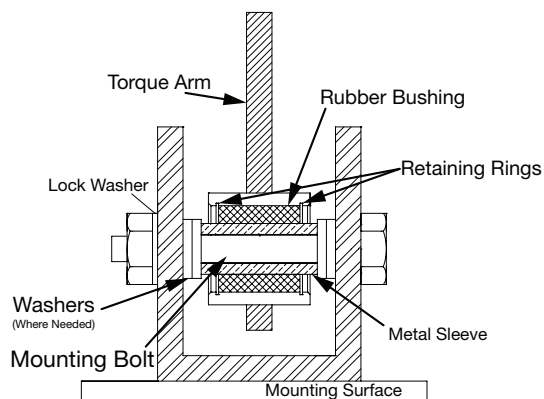

Figure 1 - Quantis Torque Arm Mounted to Customer Bracket

Installation

1. Ensure the torque arm bracket and the mounting surface is rigid and does not deflect or vibrate under load.
2. Mount the torque arm to the reducer housing using the specified bolts to the torques listed in Table 1. All possible mounting positions are shown in Figure 2. Bolts used should be secured with a thread locking compound.
3. The mounting bolt in the torque arm bracket should be securely fixed with a second nut or lock washer to prevent it from loosening when the rubber bushing compresses. At least one bolt diameter length should protrude from the nut after tightening. Ensure the bolt is centered in the torque arm bracket.
4. Use washers to prevent the bracket from touching the torque arm. Use washers in between the bracket and torque arm to ensure clearance and a snug fit.
5. Position the torque arm to align with the bracket and washers. Insert the bolt and secure with a nut or lockwasher. Do NOT force the torque arm. If it does not align properly in the bracket, move the bracket.

NOTE: The only recommended bracket should be a U-shaped bracket shown in Figure 1 to hold both sides.

**Table 1 - Torque Values
Quantis Standard Torque Arm**

Unit Size	Bolt - 8.8 Property Class	Tightening Torque (Nm)	Tightening Torque (ft-lb)
38	M8	25	18
48	M10	50	37
58	M12	90	66
68	M12	90	66
88	M12	90	66
108	M16	210	155
128	M16	210	155
148	M20	500	369
168	M20	500	369

Quantis Stainless Steel Torque Arm

Unit Size	Bolt - A2 Stainless Steel	Tightening Torque (Nm)	Tightening Torque (ft-lb)
38	M8	21	16
48	M10	42	31

Table 2 - Recommended Mounting Bolt Size

Unit Size	Bolt Size
38	M10
48	M10
58	M10
68	M10
88	M16
108	M16
128	M24
148	M24
168	M24

Bushing Replacement

1. To replace the bushing, first remove the retaining rings on both sides of the bushing.
2. Press the bushing out of the torque arm. The bushing is press fit in the torque arm when first installed.
3. Re-install one of the retaining rings. Then press the new bushing up to the retaining ring.
4. Re-install the other retaining ring.

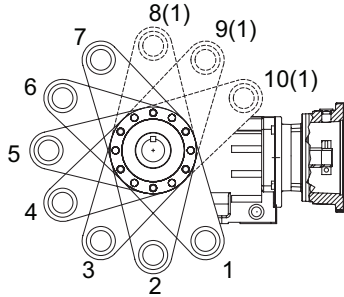

Standard Torque-Arm (KT) Possible Mounting Positions

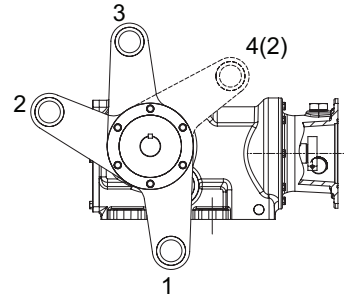

Stainless Steel Torque-Arm (KTS) Possible Mounting Positions

Notes:

1. Torque Arm can not be mounted in positions 8, 9, and 10 for washdown units because of interference with the washdown plug.
2. Stainless Steel Torque Arm can not be mounted in position 4 on size 48 reducers because of interference with the stainless steel plug.

Figure 2 - Torque-Arm Possible Mounting Positions

Dimensions

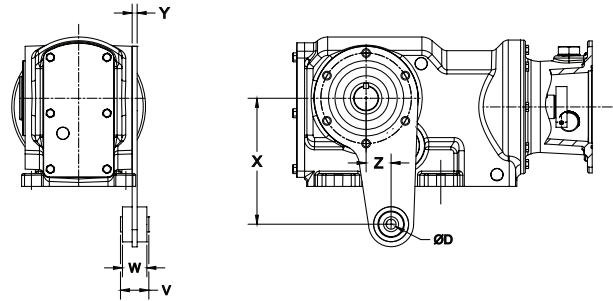
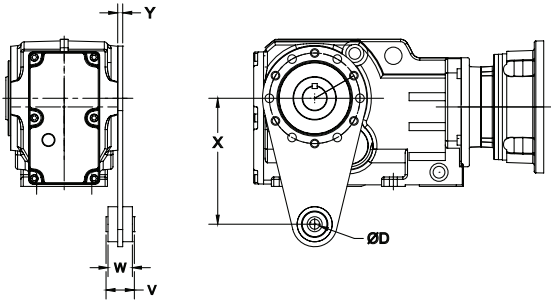

Standard Torque Arm						
Quantis Case Size	Part Number	V	W	X	Y	ØD
38	096720	1.42	1.22	5.12	0.25	10.4mm
48	096721	1.42	1.22	6.30	0.25	10.4mm
58	084544	1.42	1.22	7.56	0.375	10.4mm
68	096722	1.42	1.22	7.87	0.375	10.4mm
88	096723	2.36	2.13	9.84	0.375	16.4mm
108	096724	2.36	2.13	11.81	0.50	16.4mm
128	096725	3.15	2.83	13.78	0.50	25mm
148	096726	3.15	2.83	17.72	0.50	25mm
168	096727	3.15	2.83	21.65	0.50	25mm

Stainless Steel Torque Arm							
Quantis Case Size	Part Number	V	W	X	Y	Z	ØD
38	096710	1.42	1.22	5.12	0.25	0.85	10.4mm
48	096711	1.42	1.22	6.30	0.25	1.25	10.4mm

Dodge Industrial, Inc.
1061 Holland Road
Simpsonville, SC 29681
+1 864 297 4800

