



# Torque-Arm™ II Speed Reducer Backstop Assemblies

## Instruction Manual

These instructions must be read thoroughly before installation or operation. This instruction manual was accurate at the time of printing. Please see [dodgeindustrial.com](http://dodgeindustrial.com) for updated instruction manuals.

**WARNING:** To ensure the drive is not unexpectedly started, turn off and lock-out or tag power source before proceeding. Failure to observe these precautions could result in bodily injury.

**WARNING:** All products over 25 kg (55 lbs) are noted on the shipping package. Proper lifting practices are required for these products.

### INSTALLATION

1. Remove backstop shaft cover and gasket (Figure 1). These parts will not be reused. This cover is directly opposite the extended end of the input shaft.
2. Clean the face of the gearbox to remove any gasket material or contamination from the cover mounting surface. It is important that contamination not get into the gearbox or the backstop during the backstop installation/servicing process.
3. Face reducer looking at the side from which the cover was removed. Determine carefully the desired direction of free rotation. It is important that the direction be correctly determined because to reverse the direction after the backstop is installed, it is necessary to remove the backstop, turn it end-for-end and then reinstall it.
4. Match the arrow on the backstop inner race to the direction of free rotation for the desired direction of shaft rotation. Note that reversing the backstop end-for-end changes the direction of the arrow. The shaft will rotate in the same direction as the arrow on the backstop.
5. If the backstop kit has a spacer ring included, install it onto the shaft first, adjacent to the bearing inner ring.
6. Install the backstop inner race and sprag cage assembly onto the shaft. DO NOT remove the cage from the inner race or the shipping strap from the sprag set at this time. Insert the key into the inner race and mating shaft keyway. These parts should slip onto the shaft easily, a light coating of oil may assist in assembly. Do not use a hammer to force the installation, damage can occur to the shaft and/or the backstop. Slide the race against the spacer or the shaft shoulder and install the retaining ring into the groove in the shaft. Only use the supplied key, as it is specifically designed for each backstop.
7. Apply a thin coating of RTV silicone onto the gearbox mating surface for the outer race (same as the cover area). It is important to apply the sealant around the fastener holes to prevent leakage. Do not allow excessive amounts of silicone to enter the gearbox or to be applied to other parts.
8. Install the outer race by gently rotating it opposite the shaft rotation while pressing lightly inwards. Do not force the outer race into position as backstop damage may occur. Once the outer race is well piloted onto the sprag set, remove the shipping strap from the sprag set by cutting it, being careful not to let the outer race back off the sprags. The outer race should slide easily into position with a slight turning motion. A light coating of oil on the race inner diameter may ease installation.
9. Align the fastener holes in the outer race with the mating holes in the gearbox. Use the supplied grade 5 fasteners and lock washers only. Torque the fasteners in an alternating pattern per Table 1.

**WARNING:** Because of the possible danger to person(s) or property from accidents which may result from the improper use of products, it is important that correct procedures be followed. Products must be used in accordance with the engineering information specified in the catalog. Proper installation, maintenance and operation procedures must be observed. The instructions in the instruction manuals must be followed. Inspections should be made as necessary to assure safe operation under prevailing conditions. Proper guards and other suitable safety devices or procedures as may be desirable or as may be specified in safety codes should be provided, and are neither provided by Dodge® nor are the responsibility of Dodge. This unit and its associated equipment must be installed, adjusted and maintained by qualified personnel who are familiar with the construction and operation of all equipment in the system and the potential hazards involved. When risk to persons or property may be involved, a holding device must be an integral part of the driven equipment beyond the speed reducer output shaft. An additional warning label has been provided for the end user to place on speed reducer for convenience of easy visibility.

Table 1-Backstop Fastener Torque Values

Reducer Size	Fastener Size	Torque in ft-lbs
TA0107L	1/4-20	8 - 7
TA1107H	1/4-20	8 - 7
TA2115H	1/4-20	8 - 7
TA3203H	1/4-20	8 - 7
TA4207H	1/4-20	8 - 7
TA5215H	5/16-18	17 - 15
TA6307H	5/16-18	17 - 15
TA7315H	3/8-16	30 - 27
TA8407H	5/16-18	17 - 15
TA9415H	3/8-16	30 - 27
TA10507H	3/8-16	30 - 27
TA12608H	3/8-16	30 - 27

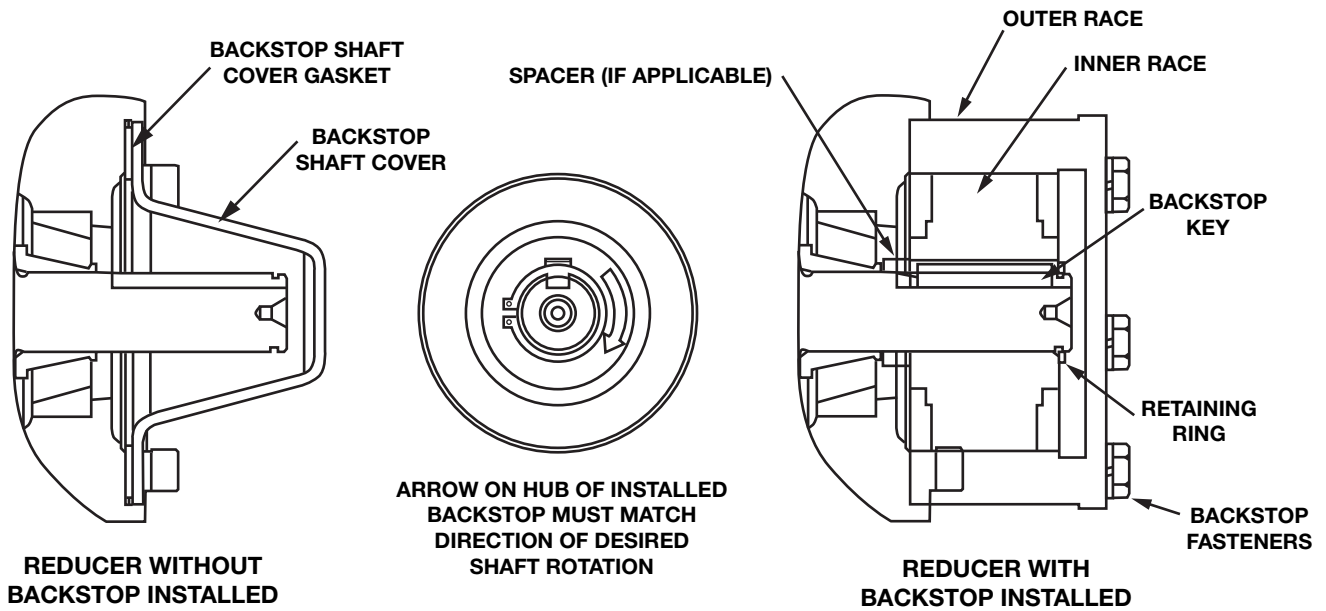

Figure 1 - Backstop Assembly

Dodge Industrial, Inc.  
 1061 Holland Road  
 Simpsonville, SC 29681  
 +1 864 297 4800

