



Hinged Cap Pillow Blocks with Tapered Roller Bearings Instruction Manual

These instructions must be read thoroughly before installation or operation. This instruction manual was accurate at the time of printing. Please see dodgeindustrial.com for updated instruction manuals.

WARNING: To ensure the drive is not unexpectedly started, turn off and lock-out or tag power source before proceeding. Failure to observe these precautions could result in bodily injury.

WARNING: All products over 25 kg (55 lbs) are noted on the shipping package. Proper lifting practices are required for these products.

INSTALLATION INSTRUCTIONS

NOTE: Hinged cap pillow blocks must be base loaded.

Installing Bearing on Shaft:

1. Install non-expansion bearing first.
2. Shaft should be within commercial tolerances, straight, smooth and clean. Apply a thin coat of light oil on the shaft.
3. Back off setscrews until they are stopped by deformed threads in end of adapter.
4. If necessary to expand adapter, loosen adapter nut and tap on end of this nut.
5. Slide bearing on shaft and locate where desired.
6. Do not bolt outer housing to support until bearing is tightened on shaft.
7. Block up shaft, if possible, to remove weight from bearing.
8. To keep adapter from turning on shaft, tap on large end opposite adapter nut. If large end of adapter is inaccessible, insert point of screwdriver between housing and adapter nut and twist screwdriver.
9. Tighten (turn clockwise) adapter nut with wrench.

WARNING: Because of the possible danger to person(s) or property from accidents which may result from the improper use of products, it is important that correct procedures be followed. Products must be used in accordance with the engineering information specified in the catalog. Proper installation, maintenance and operation procedures must be observed. The instructions in the instruction manuals must be followed. Inspections should be made as necessary to assure safe operation under prevailing conditions. Proper guards and other suitable safety devices or procedures as may be desirable or as may be specified in safety codes should be provided, and are neither provided by Dodge® nor are the responsibility of Dodge. This unit and its associated equipment must be installed, adjusted and maintained by qualified personnel who are familiar with the construction and operation of all equipment in the system and the potential hazards involved. When risk to persons or property may be involved, a holding device must be an integral part of the driven equipment beyond the speed reducer output shaft.

10. When considerable effort is required to turn adapter nut, hammer on end of nut using a soft steel or brass drift while turning with wrench. When adapter seems to be tight, also use a hammer on the wrench while hammering simultaneously on end of adapter nut.
11. Lock adapter nut by bending one prong of lockwasher into corresponding notch in back of the nut.

CAUTION: Never loosen adapter nut to next locking position.

12. Check hold-down bolts in outer housing to see that they are loose and free. (If too tight, an excessive thrust load could be imposed on bearing.) If bolts are very tight, it may be advisable to loosen adapter to move slightly on shaft.
13. Expansion Bearing: Inner unit should be located with unit housing in center of outer housing so unit can move freely in either direction. Loosen hand knob in outer housing a little so unit is free to align in outer housing. Tighten hold-down bolts. Retighten hand knob.
14. Non-Expansion Bearing: Loosen hand knob in outer housing a little so unit is free to align in outer housing. Tighten hold-down bolts. Retighten hand knob.
15. After a short run make sure adapter is tight as follows: loosen hold-down bolts and unlock adapter nut by bending out prong; perform steps 7, 9, 10 and 11. Tighten hold-down bolts.

Removing Bearing from Shaft:

1. Unlock adapter nut by bending out prong of adapter nut lock washer.
2. Loosen hold-down bolts. Block up shaft, if possible, to remove weight from bearing.
3. Loosen adapter nut about one turn, and tighten setscrews on opposite end of bearing until tapered roller bearing cone is free on adapter. Bearing can then be pushed off the shaft. If difficulty is encountered dislodging the cone, it is suggested to hammer simultaneously on end of adapter nut using a drift rod while tightening setscrews on opposite end of bearing.

LUBRICATION INSTRUCTIONS

Normal Operation—This bearing has been greased at the factory and is ready to run. The following table is a general guide for relubrication. However, certain conditions may require a change of lubricating periods as dictated by experience. See “High Speed Operation” and “Operation in Presence of Dust, Water or Corrosive Vapors.” When establishing a relubrication schedule, note that a small amount of grease at frequent intervals is preferable to a large amount at infrequent intervals.

Table 1 - Lubrication Guide								
Hours Run per Day	Suggested Lubrication Period in Weeks							
	1 to 250 RPM	251 to 500 RPM	501 to 750 RPM	751 to 1000 RPM	1001 to 1500 RPM	1501 to 2000 RPM	2001 to 2500 RPM	2501 to 3000 RPM
8	12	12	10	7	5	4	3	2
16	12	7	5	4	2	2	2	1
24	10	5	3	2	1	1	1	1

Operating Temperature—Bearing inner unit housing temperature at or above 175°F may indicate faulty lubrication. Bearing housing temperature at or above 175°F accompanied by excessive leakage of grease indicates too much grease. 175°F or higher temperature with no grease showing at the seals, particularly if the bearing seems noisy, usually indicates too little grease. Temperature below 175°F and a slight showing of grease at the seals indicate proper lubrication.

High Speed Operation—In the higher speed ranges too much grease will cause overheating. The amount of grease that the bearing will take for a particular high speed application can only be determined by experience—see “Operating Temperature.” If excess grease in the bearing causes overheating, it will be necessary to remove grease fitting (also drain plug when furnished) to permit excess grease to escape.

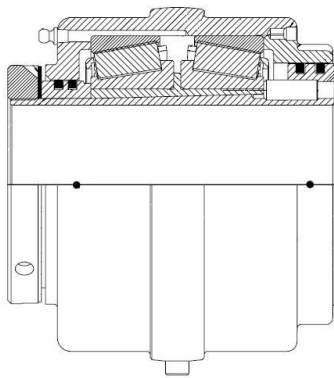

Figure 1 - Insert

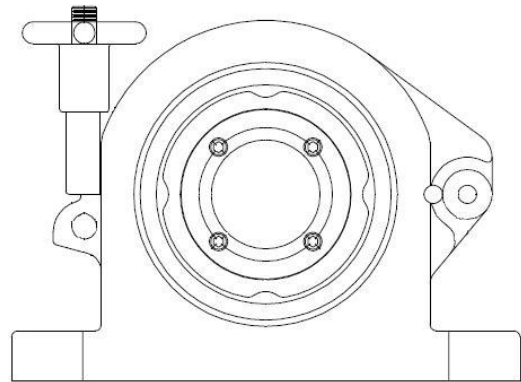

Figure 2 - Housing

Operation in Presence of Dust, Water or Corrosive Vapors—Under these conditions the bearing should contain as much grease as speed will permit, since a full bearing with consequent slight leakage is the best protection against entrance of foreign material. In the higher speed ranges too much grease will cause overheating—see “High Speed Operation.” In the lower speed ranges it is advisable to add extra grease to a new bearing before putting into operation. Bearings should be greased as often as necessary (daily if required) to maintain a slight leakage at the seals.

Special Operating Conditions—Refer acid, chemical, extreme or other special operating conditions to Dodge Application Engineering, 864-284-5700.

Storage or Special Shutdown—If exposed to wet or dusty conditions or to corrosive vapors, extra protection is necessary; Add grease until it shows at the seals; rotate the bearing to distribute grease; cover the bearing. After storage or idle period, add a little fresh grease before running.

Kind of Grease—Many ordinary cup greases will disintegrate at speeds far below those at which Dodge bearings will operate successfully if proper grease is used. Dodge bearings have been lubricated at the factory with No. 2 consistency Lithium complex-base grease. Relubricate with Lithium complex-base grease or a grease which is compatible with original lubricant and suitable for roller bearing service. In unusual or doubtful cases the recommendation of a reputable grease manufacturer should be secured.

Dodge Industrial, Inc.
1061 Holland Road
Simpsonville, SC 29681
+1 864 297 4800

