

Installation and Instruction Manual for Dodge TAIL Speed Reducer Belt Guard Assemblies

These instructions must be read thoroughly before installation or operation. This instruction manual was accurate at the time of printing. Please see dodgeindustrial.com for updated instruction manuals.

WARNING: To ensure the drive is not unexpectedly started, turn off and lock-out or tag power source before proceeding. Failure to observe these precautions could result in bodily injury.

WARNING: All products over 25 kg (55 lbs) are noted on the shipping package. Proper lifting practices are required for these products.

WARNING: Ensure that all guards are properly installed before proceeding. Exercise extreme care to avoid contacting rotating parts. Failure to observe these precautions could result in bodily injury.

WARNING: Because of the possible danger to person(s) or property from accidents which may result from the improper use of products, it is important that correct procedures be followed. Products must be used in accordance with the engineering information specified in the catalog. Proper installation, maintenance and operation procedures must be observed. The instructions in the instruction manuals must be followed. Inspections should be made as necessary to assure safe operation under prevailing conditions. Proper guards and other suitable safety devices or procedures as may be desirable or as may be specified in safety codes should be provided, and are neither provided by Dodge nor are the responsibility of Dodge. This unit and its associated equipment must be installed, adjusted and maintained by qualified personnel who are familiar with the construction and operation of all equipment in the system and the potential hazards involved. When risk to persons or property may be involved, a holding device must be an integral part of the driven equipment beyond the speed reducer output shaft.

Installation Instructions

1. Remove the belt guard components from the box and compare the contents to parts list to ensure all parts were included.

NOTE: These belt guards are designed to only be used on Dodge TAIL gearboxes and motors mounts, for Position B motor mount M2 shown in Figure 1.

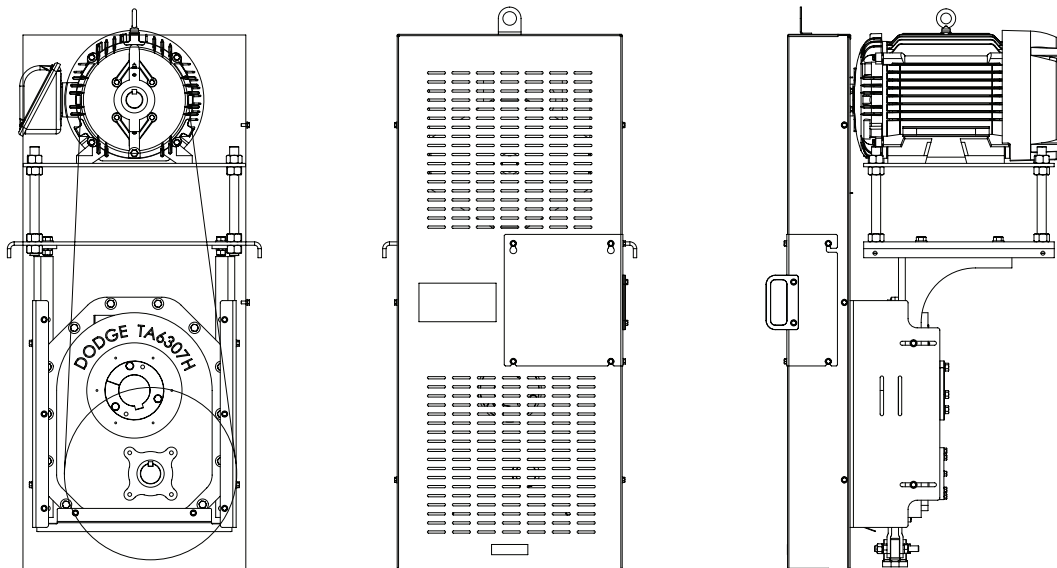

Figure 1 - For Position B Mounting

- Attach two front cover lifting handles to the front cover on small guards. On larger belt guards equipped with an inspection cover, attach one handle to the inspection cover as shown in Figure 2. Insert and tighten the two mounting screws on each lifting handle. If equipped with an inspection cover, attach the inspection cover to the front cover and insert and tighten the six screws.

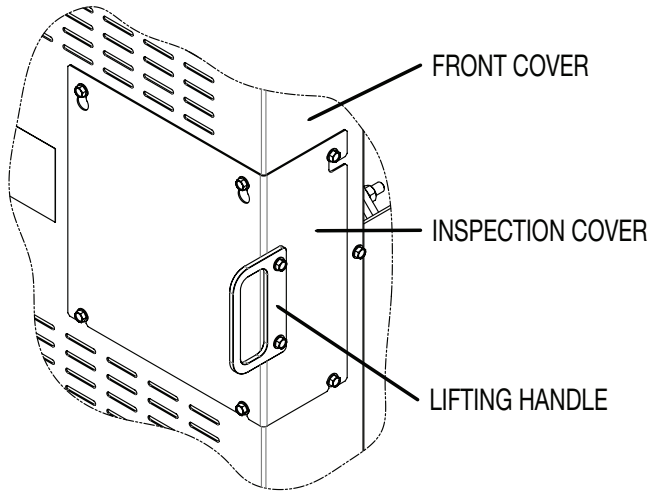

Figure 2 - Attach handle

- Assemble the mounting brackets & lower baffle to the back cover as shown in Figure 3. Insert and tighten the three screws on each mounting bracket & two screws on the lower baffle.

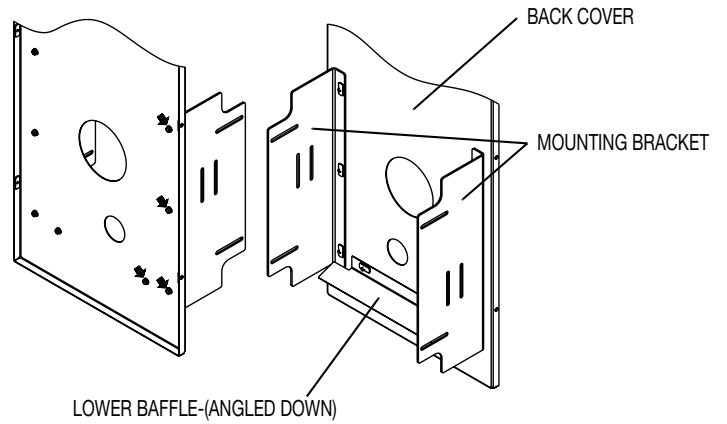

Figure 3 - Assemble the mounting bracket & lower baffle

Make sure the four screws that hold the moveable motor shaft guard in place have been loosened but not removed. Refer to Figure 4. Position the back cover assembly on the gearbox by lining up the hole in the moveable motor shaft guard with the motor shaft while lining up the lower hole with the gear reducer input shaft. Slide the moveable motor shaft guard as needed. Slide back cover assembly as close as possible to the gear reducer and motor, and line up the holes in the mounting brackets with the holes in the motor mount vertical supports. Insert and tighten the long screws and nuts on each mounting bracket.

- Install the v-belts and sheaves according to the manufacturer's instructions. Slide the motor shaft guard as needed during tensioning of the belts. After the motor has been moved to the final position during belt tensioning, slide the motor shaft guard to clear the motor shaft and key equally around the shaft opening in the motor shaft guard. Rotate the motor shaft if possible to ensure the key does not contact the guard. Tighten the four motor shaft guard mounting screws.

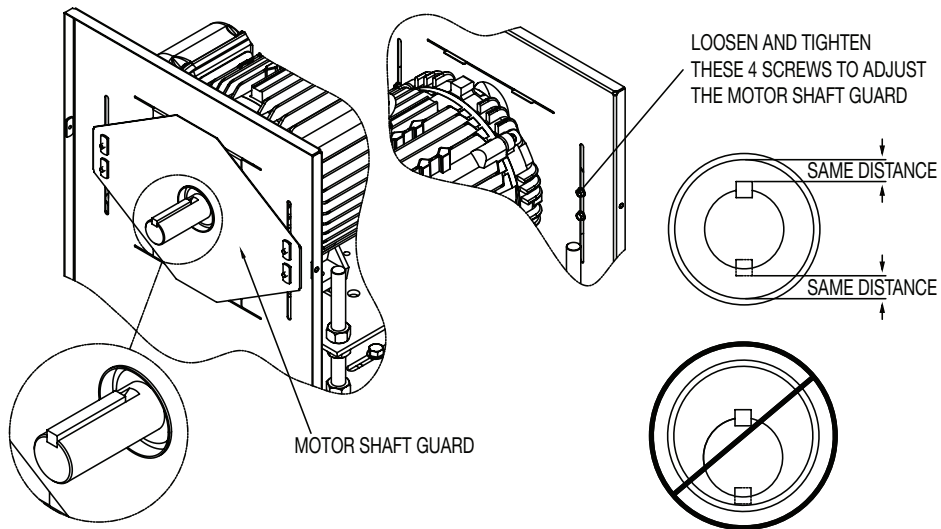

Figure 4 - Loosen motor shaft screws

5. Install the front cover by lifting the front cover higher than the top of the back cover using the lifting handles or lifting bracket, shown in Figure 6, attached to the front cover. Use an appropriate lifting device when using the lifting bracket. The lifting bracket is to be used to only lift the front cover. The lip on the front cover must go over the top of the back cover. Refer to Figure 5.

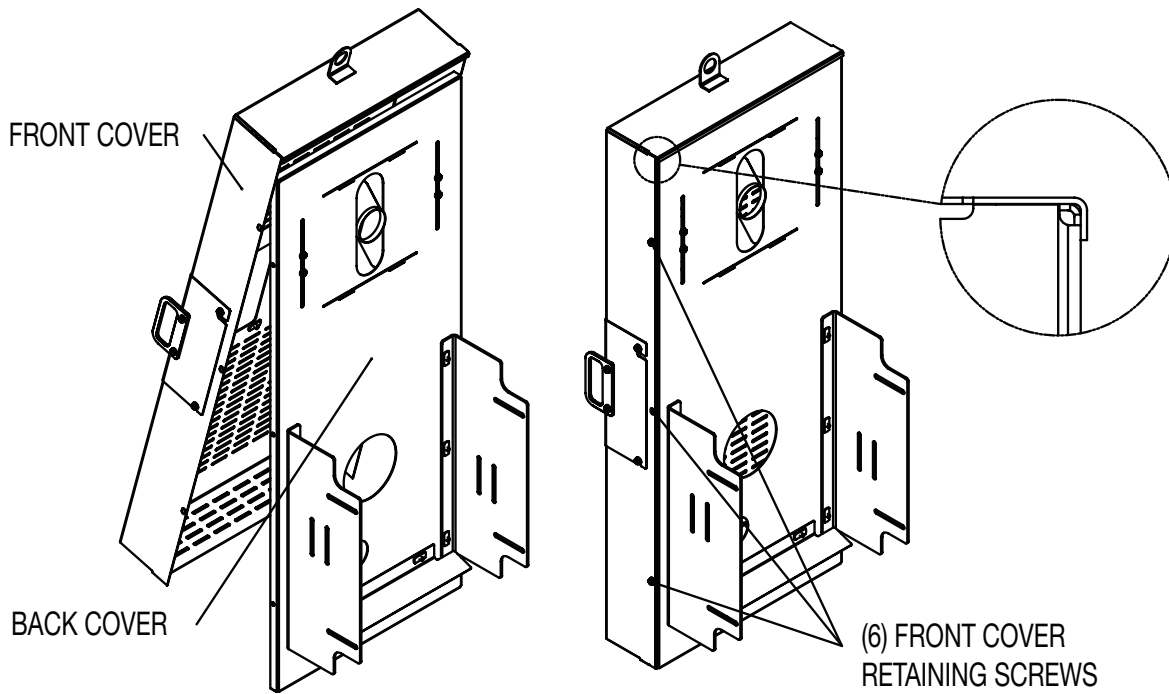

Figure 5 - Installation of the front cover

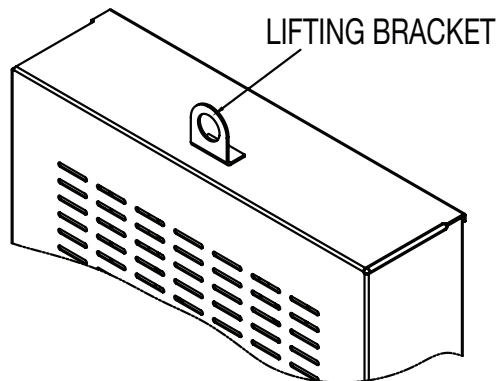

Figure 6 - Use of the lifting bracket

Checking V-Belt Tension on Units Equipped without Inspection Cover

1. To gain access to the v-belts on belt guards without an inspection cover, remove the six front cover screws. Use the lifting handles attached to the front cover to lift the front cover up slightly to clear the top of the back cover.
2. After the top of the back cover has been cleared, remove the front cover from the back cover by moving the front cover away from the back cover.
3. Reverse the procedure to install the front cover.

6. Lower the front cover into position and insert and tighten the six screws on the sides of the front cover.

Checking V-Belt Tension on Units Equipped with Inspection Cover

1. To gain access to the v-belts on belt guards with an inspection cover, loosen, but do NOT remove, the six screws that hold the inspection cover onto the front cover. Refer to Figure 7.
2. Slide the inspection cover up to align the larger holes in the slots with the screw heads and then slide the inspection cover away from the front cover. To temporarily store the inspection cover, hang the inspection cover on the lower screws. Refer to Figure 8.
3. To reinstall the inspection cover, line up the large holes on the front of the inspection cover with the screw heads in the front cover and slide the inspection cover onto the screws on the side of the front cover. Tighten the six screws after the inspection cover is in place.

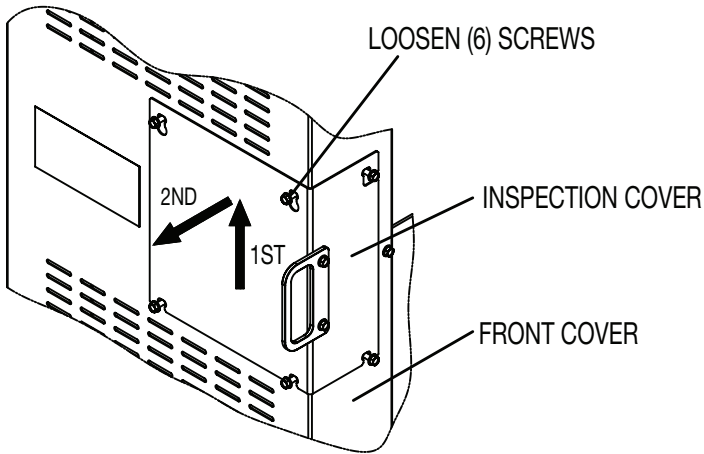

Figure 7 - Equipped with inspection cover

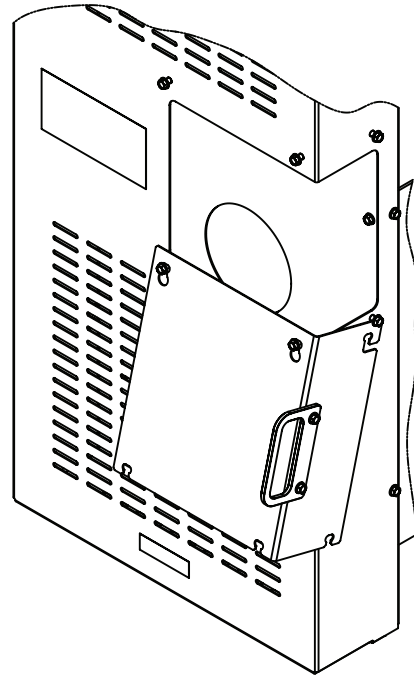

Figure 8

Dodge Industrial, Inc.
1061 Holland Road
Simpsonville, SC 29681
+1 864 297 4800

© DODGE INDUSTRIAL, INC.
AN RBC BEARINGS COMPANY



All Rights Reserved. Printed in USA.
MN16023 03/22