

# INSTRUCTION MANUAL FOR LD and HD TAKE-UP FRAME ASSEMBLIES

These instructions must be read thoroughly before installation or operation.

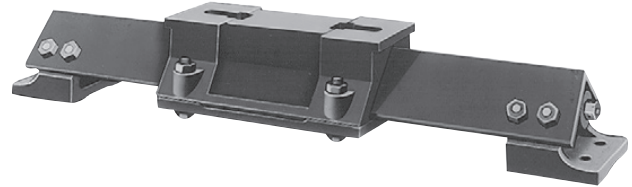

**LD TAKE-UP FRAME**



**HD TAKE-UP FRAME**

- 1) Make sure that the take-up frame will accommodate the required bearing.
- 2) Bolt frame to mounting structure using adequate bolts and under extreme loading, a stop bar should be welded to the mounting structure in the direction of load.
- 3) If two frame assemblies are used to support a shaft, make sure that the frame angles are parallel to each other to prevent binding and preloading of the bearing.
- 4) Mount bearing per the instruction manual supplied with the bearing.
- 5) Tighten hold down bolts to the recommended torque values shown on the tables.
- 6) When tensioning the belt of a conveyor system—insure that the two take-up frames move in tandem.

**Note:** LD Frames are welded together and must be replaced as a unit.

Adjusting screws on each take-up should be turned simultaneously in small increments to prevent excessive misalignment loads on the bearings.

**Bearing Mounting Bolt  
Torque Recommendations**

Bolt Dia.	Torque Ft.-Lbs.
3/8-16	20
1/2-13	50
5/8-11	100
3/4-10	175
7/8-9	170
1-8	250
1-1/8-7	350

**WARNING:** Because of the possible danger to person(s) or property from accidents which may result from the improper use of products, it is important that correct procedures be followed. Products must be used in accordance with the engineering information specified in the catalog. Proper installation, maintenance and operation procedures must be observed. The instructions in the instruction manuals must be followed. Inspections should be made as necessary to assure safe operation under prevailing conditions. Proper guards and other suitable safety devices or procedures, as may be desirable, or as may be specified in safety codes should be provided, and are neither provided by Dodge, nor are the responsibility of Dodge. This unit and its associated equipment must be installed, adjusted and maintained by qualified personnel who are familiar with the construction and operation of all equipment in the system and the potential hazards involved. When risks to persons or property may be involved, a holding device must be an integral part of the driven equipment beyond the speed reducer output shaft.



## HD TAKE-UP FRAME ASSEMBLIES

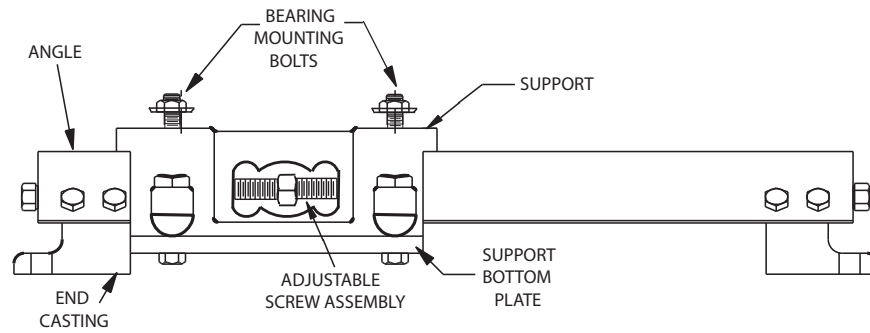

Frame Size and Travel	Adj. Screw Assembly	Support	Support Bottom Plate	Angle	End Casting (2/Frame)	Brg. Mounting Bolts (2/Frame)
200 × 12	089084	089001	089005	089050	089009	416173
200 × 18	089085	089001	089005	089051	089009	416173
200 × 24	089087	089001	089005	089052	089009	416173
200 × 30	089089	089001	089005	089053	089009	416173
200 × 36	089109	089001	089005	089142	089009	416173
200 × 48	089137	089001	089005	089138	089009	416173
250 × 12	089163	089002	089006	089165	089010	416229
250 × 18	089086	089002	089006	089054	089010	416229
250 × 24	089088	089002	089006	089055	089010	416229
250 × 30	089090	089002	089006	089056	089010	416229
250 × 36	089091	089002	089006	089057	089010	416229
250 × 48	089189	089002	089006	089191	089010	416229
300 × 12	089144	089003	089007	089139	089011	416231
300 × 18	089092	089003	089007	089058	089011	416231
300 × 24	089094	089003	089007	089060	089011	416231
300 × 30	089096	089003	089007	089062	089011	416231
300 × 36	089098	089003	089007	089064	089011	416231
300 × 48	089147	089003	089007	089145	089011	416231
350 × 12	089192	089004	089008	089194	089011	416275
350 × 18	089093	089004	089008	089059	089011	416275
350 × 24	089095	089004	089008	089061	089011	416275
350 × 30	089097	089004	089008	089063	089011	416275
350 × 36	089099	089004	089008	089065	089011	416275
350 × 48	089254	089004	089008	089253	089011	416275
400 × 12	089160	089018	089019	089158	089011	+
400 × 18	089100	089018	089019	089066	089011	+
400 × 24	089216	089018	089019	089217	089011	+
400 × 30	089238	089018	089019	089237	089011	+
400 × 36	089185	089018	089019	089184	089011	+
400 × 48	089149	089018	089019	089148	089011	+
500 × 12	089195	089101	089102	089197	089049	+
500 × 18	089110	089101	089102	089140	089049	+
500 × 24	†	089101	089102	†	089049	+
500 × 30	†	089101	089102	†	089049	+
500 × 36	089111	089101	089102	089141	089049	+
500 × 48	089176	089101	089102	089174	089049	+

† Consult DODGE for Availability  
+ Not Applicable

**Dodge Industrial, Inc.**  
1061 Holland Road  
Simpsonville, SC 29681  
+1 864 297 4800



\* 3 0 4 6 - 0 2 2 2 \*