

# INSTRUCTION MANUAL for 1-7/16" SLEEVOIL® Plain Pillow Block

These instructions must be read thoroughly before installing or operating this product. This instruction manual was accurate at the time of printing. Please see [dodgeindustrial.com](http://dodgeindustrial.com) for updated instruction manuals.

**WARNING: All products over 25 kg (55 lbs) are noted on the shipping package. Proper lifting practices are required for these products.**

**WARNING: To ensure that drive is not unexpectedly started, turn off and lock out or tag power source before proceeding. Failure to observe these precautions could result in bodily injury.**

**CAUTION: Do not scrape, rebabbitt or otherwise alter this product. Such action adversely affects bearing performance and may result in damage to or destruction of equipment.**

## INSTALLATION

Check mounting structure making sure it is rigid, level and well supported. Inspect shaft to ensure it is smooth (32 micro-inch finish or better), within commercial tolerances and free of burrs or rough spots.

1. Disassemble and thoroughly clean all parts of the pillow block. Housing caps and liner caps are matched to their bases and are not interchangeable. Housing and liners should be interchanged as assemblies only.

**WARNING: Rust preventives and solvents can be toxic and/or flammable. Follow directions and safety procedures recommended by their manufacturers.**

**CAUTION: Liner assembly has critical machined surfaces which are easily damaged. Use care in handling to protect these surfaces. Liner parts should be placed on a soft, CLEAN surface.**

2. Position housing base on pedestal so that oil gauge is in the position specified on the construction drawing. **Do not tighten housing base to pedestal.** Apply oil to the spherical seats in the housing base.
3. Set liner base in housing base and apply oil to liner bearing surface.
4. Apply oil to shaft in the bearing area and set shaft in place.

**WARNING: Because of the possible danger to persons(s) or property from accidents which may result from the improper use of products, it is important that correct procedures be followed. Products must be used in accordance with the engineering information specified in the catalog. Proper installation, maintenance and operation procedures must be observed. The instructions in the instruction manuals must be followed. Inspections should be made as necessary to assure safe operation under prevailing conditions. Proper guards and other suitable safety devices or procedures as may be desirable or as may be specified in safety codes should be provided, and are neither provided by Dodge nor are the responsibility of Dodge. This unit and its associated equipment must be installed, adjusted and maintained by qualified personnel who are familiar with the construction and operation of all equipment in the system and the potential hazards involved. When risk to persons or property may be involved, a holding device must be an integral part of the driven equipment beyond the speed reducer output shaft.**

5. Check alignment of pillow block by noting clearance between housing and shaft at each end of the housing. Clearance should be uniform within 1/32". Shim bearing pedestal where possible, otherwise use full length shims under base as required. Alignment of pillow block should be as accurate as possible. The self-alignment feature of the unit is to compensate for normal shaft deflection and possible setting of the supports.
6. Place oil rings around outside of lower liner and over shaft. Peen screws to ensure that they are secure. Make sure rings rotate freely on shaft.
7. Thrust Collars, in a fixed unit, should now be installed. Remove clamp screws from thrust collars and clean cracked joint with wire brush. Back off set screws to clear inside of collar. Place one collar half on shaft so shaft flinger groove is next to liner base in the non-expansion (fixed) bearing. Rotate collar half around shaft and place other half in position. Bring halves together at joint, making sure match at joint is perfect and insert clamp screws. There should be no offset at collar face. Tap halves together and tighten 1/4-20 NC (Soc. Hex) clamp screws to recommended torque of 160 in-lb.. Repeat above operation for opposite end of bearing. Assemble two collars on one bearing only. Tap collar up to face of lower liner allowing a total running clearance of .006"-.012", then tighten 5/16-18 NC (Soc. Hex) set-screws to recommended torque of 140 in-lb. Collar should run parallel to end face of liner within .002".
8. Apply oil to bearing surface of liner cap. Locate cap in place on lower liner making sure oil ring is free to rotate. The 1-7/16" SLEEVOIL liners have upper halves that are normally reversible on the lower half. By design, they are not doweled together and therefore not match-marked.

Two modifications which require match-marking of these small PLAIN liners, 1-7/16" are:

- a. **When using full (Type II) Bronze Thrust Plates:** Since liners are doweled together and machined as an assembly, care must be used to ensure match marks are adjacent to each other and identical. The match marks will be on the Bronze Thrust Plate halves for face squareness after machining. A liner with Type II Bronze Thrust Plates is rigid and does not allow the upper half to self-align to the plunger screw. **To compensate for loss of self-alignment, a special plunger screw and plunger screw washer are required.** The special loose washer must be positioned on the upper liner plunger screw seat and under the plunger screw. This ensures proper alignment of the liner bore to shaft during operation.
  - b. **When Liners Have a Cylindrical Bore:** The liners are doweled together and match marked. Rotating liner halves, or switching liner halves from one liner to another, can change the clearances within the liner. These actions can change operating clearances within the liner and adverse machine response can occur.
9. Tighten housing base to pedestal. Torque 5/8" bolts to 1200 in-lb.



## LUBRICATION and OPERATION

10. Thread dust seal and seal spring into groove at end of housing base and around shaft. Hook ends of spring together; taking care not to overstress spring when stretching. Permanent set can cause loss or working load and looseness on shaft; resulting in oil leakage during operation. If unit is furnished with auxiliary seals, install a second seal on each end. If using End Closure, neoprene discs should be installed at this time. Consult construction drawing for type of seal recommended.
11. Apply Gasket Eliminator to Sleeve housing base along outer contour of joint. **Loosen plunger screw** and locate housing cap on base taking care not to damage dust seals or gasket material. To reduce chances for leakage, a non-hardening sealant must be used under cap bolts. Tighten housing bolts to 240 in-lb. **The plunger screw must be loose until the housing bolts have been tightened.** These SLEEVOIL plain housings have match marks permanently stamped on them beginning June 1988. These match marks permanently ensure that parts stay paired and critical orientation of assemblies is maintained.

**Cap Loaded Bearings:** The shaft must be held down to install cap. Tighten plunger screw to recommended torque of 250 in-lb. with shaft held down. Mark position of plunger screw. Loosen plunger screw one complete turn and loosen shaft hold down. Then tighten plunger screw while tightening shaft hold-down until plunger screw is tightened to the mark. Do not over-tighten shaft hold-down as this can misalign the bearing. Remove shaft hold-down and tighten plunger screw locknut. Note: Do not tighten plunger screw on accompanying base loaded bearing until cap loaded bearing has been installed and hold-down removed.

**Base Loaded Bearings:** Tighten plunger screw to recommended torque of 250 in-lb. and tighten locknut.

**IMPORTANT: Check and re-torque plunger screw to the specified torque after 24 hours of initial start-up, and then check periodically as required.**

12. The oil level gauge may be located any distance from the pillow block by the use of a coupling and pipe of the desired length. The extended pipe must be supported so that it remains straight and perfectly level. Use a spirit level, do not guess. Use pipe sealer on all connections.
13. Remove all pipe plugs and flush liner bore and housing thoroughly with solvent or cleaner. Reinstall pipe plugs using pipe sealer. Tighten securely.
14. Each housing base has predrilled holes for doweling bearing to base plate.

Since the satisfactory operation of the pillow block depends almost entirely on the oil film being maintained between the shaft and liner bearing surface, it is recommended that a high grade straight mineral oil with rust and oxidation (R & O) inhibitors and anti-foam agents be used. Check equipment specifications for specific recommendations of oil viscosity by equipment manufacturer. Oil viscosity is determined by the equipment manufacturer and normally specified on the construction drawing.

Fill the pillow block with oil to the top of the center circle in the oil gauge. After placing into operation, remove inspection covers and check to make sure oil rings are bringing up oil. Operation should be checked frequently during the first few days. After some running of base loaded bearings only, loosen plunger screw 1/4 turn, then retighten. This will allow the liner to align with the shaft. For cap loaded bearings, follow installation procedure. If noise develops, check alignment of housing, collar runout, plunger screw and all operating parts. Check all points and make sure all screws and nuts are tightened after several days operation.

### Oil Maintenance Schedule

Drain, flush, and refill with oil after 2 to 3 weeks of initial break-in operation. Since the satisfactory operation of the bearing depends entirely on an oil film being maintained between the shaft and the bearing liner surface, it is recommended that an oil analysis be performed at these regular intervals.

- Every 3 months for 24 hour/day service
- Every 6 months for 8 hour/day service

Acceptability of oil should be referred to the lubricant manufacturer. If oil quality is acceptable then repeat this procedure in three month intervals. Visually check oil for contamination between oil analysis checks. Oil service life depends upon several factors such as ambient conditions, operating temperature and frequency of bearing starts and stops. It is recommended that the oil be changed at least once per year for unfiltered static applications. Removing contaminants through the use of either the OLF-2 (Oil Level and Filtration) unit, Cool Lube 2, or a circulating oil system can extend oil service life. Consult equipment manufacturer for more information. Maintain oil level above bottom of center circle at all times while unit is in operation.

**NOTE: The MINIMUM oil temperature at start-up is 70°F.**

Oil film temperature in liner during operation should not exceed 180°F. If in doubt, consult equipment manufacturer.

Any question on installation, maintenance, or arrangement of should be referred to the original equipment manufacturer.

## Pillow Block Material Details

Housing:	Class 30 Gray Cast Iron
Liner:	Class 30 Gray Cast Iron
Babbitt:	Lead or Tin Based Babbitt
Oil Rings:	Bronze
Aux. Seal:	HNBR with Stainless Steel Retainer
Grommet:	Synthetic Rubber
Grommet Plate:	Carbon Steel
Pipe Nipple:	Carbon Steel
Oil Gauge:	Stainless Steel, Polypropylene
Hardware:	Carbon Steel
Plunger Screw:	Carbon Steel
Gasket Eliminator:	LOCTITE 515 Sealant

This Sleeveoil pillow block could contain lead in the bearing Babbitt material, please exercise proper precautions in the use, installation, dismantling and recycling of this unit.

## Other Notes:

**CAUTION:** This product is not to be used for person moving applications.

**NOTE:** Care has been taken to keep instruction manuals accurate and timely. The most recent version of the instruction manual can be found on our website: [www.dodgeindustrial.com](http://www.dodgeindustrial.com)

R-series shaft size	Approximate Weight (lbs.)		
	Non-Expansion Pillow Block	Expansion Pillow Block	Liner Assembly
1-7/16	22	21	4

## Parts for 1-7/16" SLEEVOIL Plain Pillow Blocks

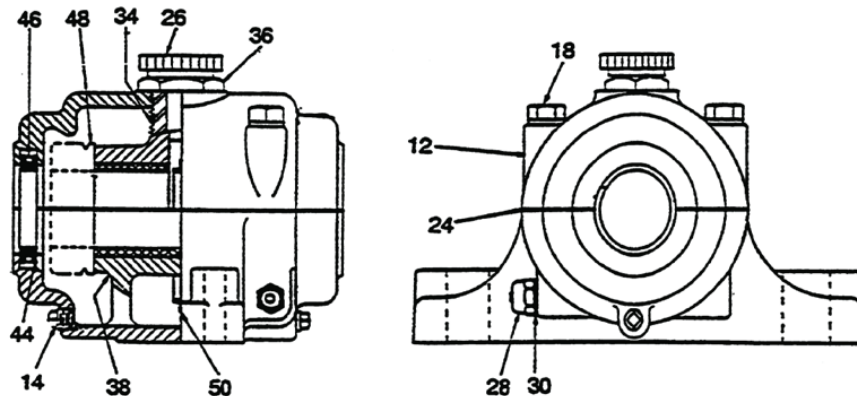

Order parts by the six-digit part numbers in the Parts list. Each six-digit number is complete identification of the part or assembly.

These SLEEVOIL plain housings and SLEEVOIL liners have nameplates attached containing a six-digit part number which fully identifies the housing and/or liner. Liner nameplates are pinned to the SLEEVOIL liner cap near an oil ring inspection hole. Housing nameplates are pinned to the housing foot parallel to the shaft. Refer to these part numbers when ordering replacement parts.

Ref	Name of Part	Number Required	Part Number	Ref	Name of Part	Number Required	Part Number	Ref	Name of Part	Number Required	Part Number
12	Exp Pillow Block	1	132983	28	② Oil Gauge	1	430139	46	② Seal Retainer	2	-
②	Modular Housing	1	132940	30	② Oil Gauge Gasket	1	418110	48	Thrust Collar	2	133245
18	② Housing Bolt	4	411079	34	② Plunger Screw	1	422392	50	Oil Ring	1	135700
14	② Drain Plug	2	430008	36	② Plunger Screw Nut	1	133368	①	End Cover ③	1	133980
①	② Oil Level Plug	1	430012	② 38	Liner Assembly ④	1	133203	①	② Split End Plate	④	133123
24	② Gasket Eliminator	2	427359	②	Dust Seal Kit	1	389820	①	② End Plate Cap Screw	4	417041
②	② Inspection Cover	1	405005	44	② Dust Seal	2	-				
26	② Nameplate	1	404550								

① Not shown on drawing

② Parts marked are furnished with the assemblies under which they are listed

③ Neoprene disc for use, when desired, on installations where shaft does not extend through housing

④ Auxiliary plate for bolting to one or both ends of housing where conditions are extremely dirty and in outdoor installations. Requires one additional dust seal and seal spring per end plate.

## Sleevoil Accessories

The following accessories are available for Sleeveoil bearing to enhance operation and extend bearing life. For compatibility and technical information contact DODGE product support.



### OIL LEVEL AND FILTRATION (OLF-2) SYSTEM

- Increase bearing longevity and reliability.
- One OLF-2 system supplies two bearings with a continuous flow of filtered oil.
- The oil is supplied directly to the circulating oil inlets on the bearings, which helps minimize wear during startups and shutdowns.



### DODGE SLEEVOIL BEARING ISOLATOR

- Fully split multi-labyrinth sealing system.
- Provides outstanding protection in harsh and dirty environments.
- IP56 rated



### RTD KIT

- Prevent catastrophes by accurately measuring bearing temperature.
- Features a field-cuttable stainless steel probe, a platinum sensing element and a spring-loaded fitting with an oil seal.

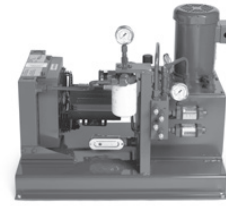

### COOL LUBE 2

- All the features of the OLF-2 system plus a built-in heat exchanger for continuous oil cooling and adjustable oil flow controls.
- Particularly well suited in applications where bearing operating temperatures and speeds approach the maximum permissible levels.



### HEATER/THERMOSTAT

- The bearing sump heater and thermostat have been combined into one user-friendly unit.
- Sump heaters are a necessity to ensure safe startups when bearings are exposed to ambient temperatures below 70°F.



### THERMOMETER

- Dial thermometer for convenient monitoring of the oil sump temperature
- All stainless steel construction with glass face



### COOLANT HOSE KIT

- An easy to install solution for connecting coolant lines to your Sleeveoil bearing.
- Durable flexible hoses are composed of a synthetic rubber inner tube reinforced with fiber and steel braids.

Dodge Industrial, Inc.  
1061 Holland Road  
Simpsonville, SC 29681  
+1 864 297 4800



\* 3 0 5 4 - 0 2 2 2 \*