

MECHANICAL POWER TRANSMISSION

Tigear-2®

Right angle gear reducers

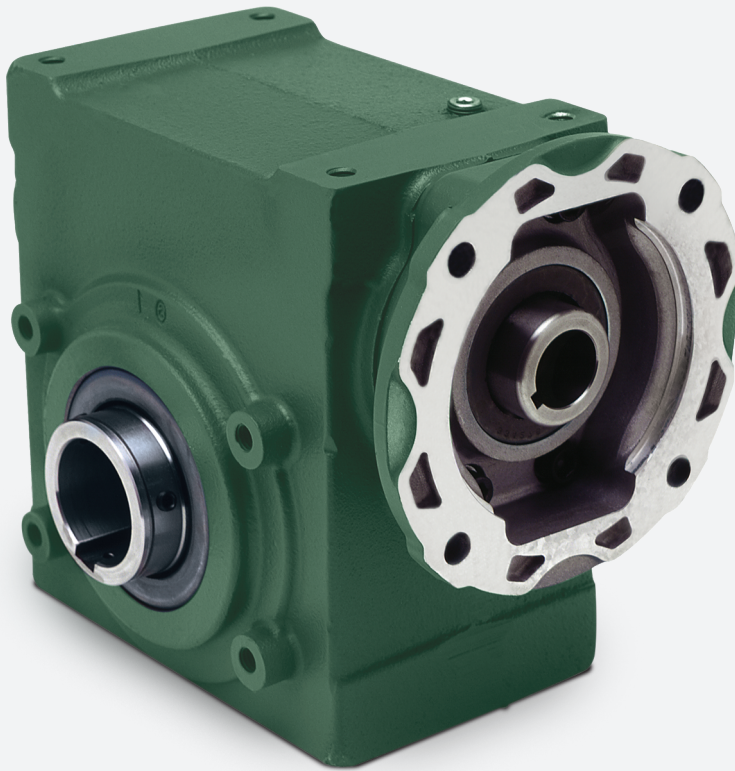

- Market-leading worm gear reducer in material handling
- Lowers your total cost of ownership
- Offered in 12 sizes

Tigear-2 speed reducers

Engineering that raises the bar

The Tigear-2 reducer is designed with a totally enclosed ventless sealing system that contains a factory-filled food grade synthetic lubricant that runs cooler and eliminates the need for routine oil changes.

Ready to install

- Factory-filled with oil
- One oil level for all mounting positions
- No breather to install

Long life

- Precision-cut gearing with fine-grain bronze
- Class 30 gray iron gearcase housings
- Factory-filled food grade synthetic lube
- Hydrogenated nitrile rubber sealing

Comprehensive offering

- 12 case sizes covering center distances from 1.33" to 4.75" and up to 6,800lb-in of torque
- Sanitary designs for food and beverage industry applications
 - E-Z Kleen® painted washdown
 - Food Safe stainless steel rounded top housing
- Flexible mounting options and accessories

Excellent availability

- Same-day shipment available from stock
- Short transit times from 3 stocking locations in Crossville, TN, Dallas, TX and Reno, NV
- Made-to-order capabilities

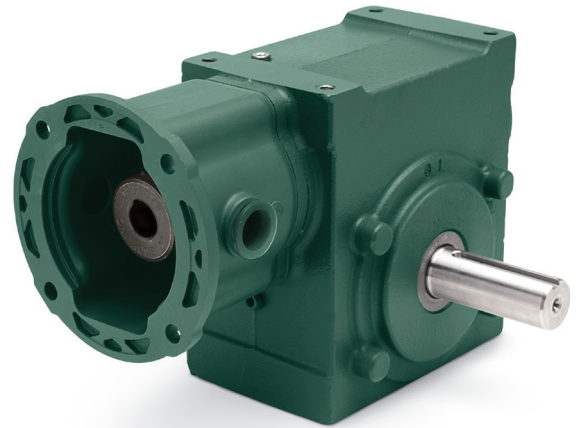

Extreme flexibility

For a wide range of applications

The advanced design concept of the Tigear-2 reducer product line provides extreme flexibility for applications that require from 100 up to 6,800 lb.-in. of torque. Whether the application requires the compactness of a quill-style input, the durability of a 3-piece coupled input, or a separate keyed input shaft for belt-driven equipment, Tigear-2 is the answer. With six basic reducer configurations and stock bolt-on accessories, the Tigear-2 reducer can offer a solution to almost any customer need.

Quill input

Space-saving quill-style input reducers for NEMA C-face motors in both solid and hollow output designs.



3-piece coupled input

A 3-piece coupled input for NEMA C-face motors creates a durable drive package that facilitates easy motor removal and provides protection against shock loads and other unpredictable vibrations.

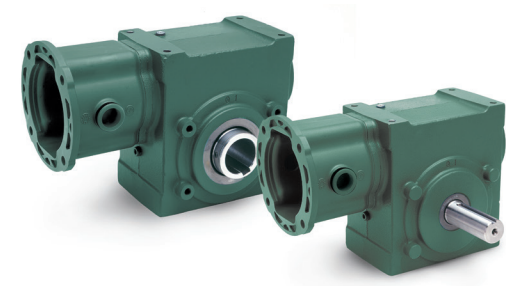

Separate input

Separate style input reducers with solid or hollow output shafts are suitable for either belted or direct-coupled motor connections. A 3-piece coupled adapter kit can be added to a separate input for maximum inventory flexibility.

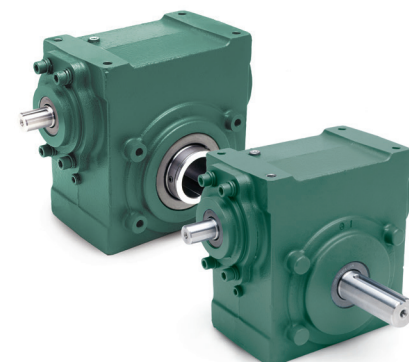

Reliability

Innovative features that reduce maintenance

Ventless Design

Eliminates potential oil contamination

Tapered roller bearings

Provides industry leading overhung load ratings for long life in belted applications

HNBR seals

Compatible with synthetic oil and a greater operating temperature range than Viton

Bronze gear material

Provides maximum durability and minimum wear

Factory filled with food grade synthetic lubricant

Allows greater efficiency and cooler operating temperatures

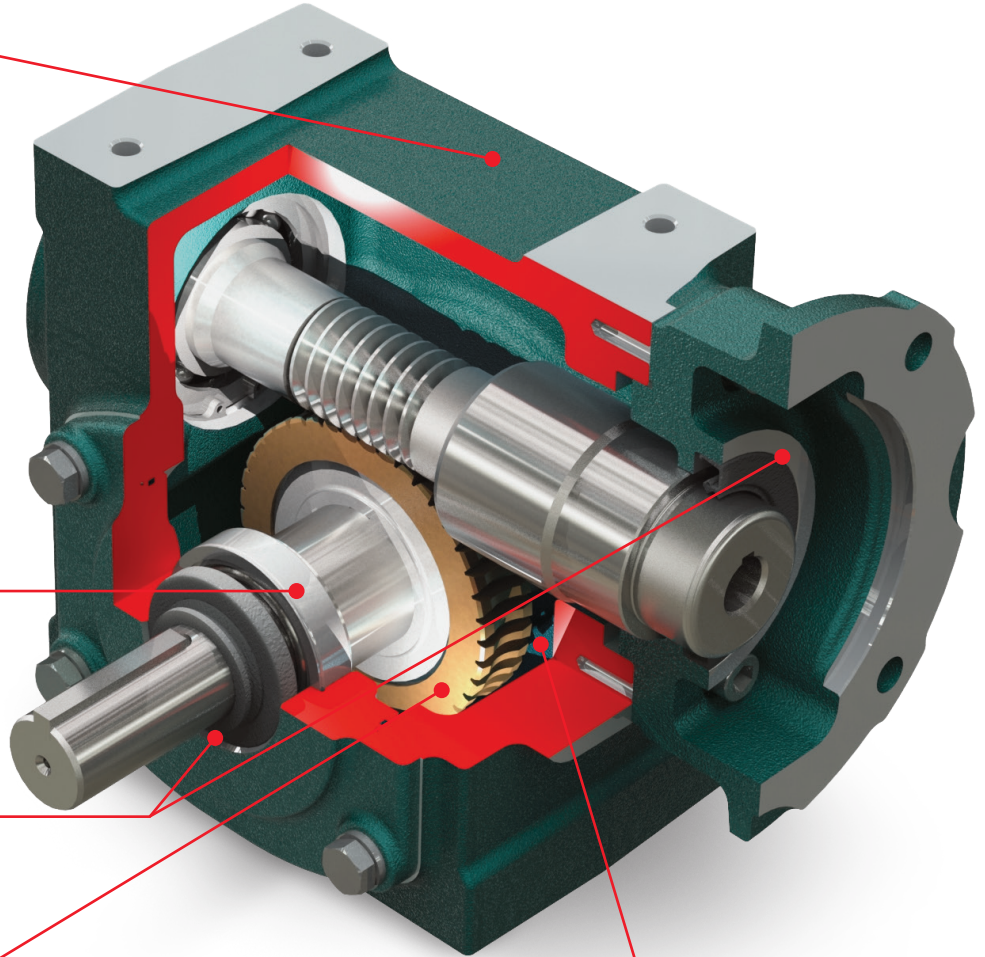

Safety

The safest product is one that is designed to operate reliably with minimal human interaction

Routine maintenance introduces safety hazards as employees must closely interact with equipment that is difficult to access or located in dangerous areas. Safety is always a top priority, which is why the Tigear-2 is designed with features that increase productivity, reduce maintenance, and operate safely.

Designed and manufactured for safety and reliability

- Tapered roller bearings that feature best in class OHL ratings, resulting in longer service life
- Synthetic, food grade lubrication extends life and provides safe operation
- Sanitary design reduces potential contamination locations in food applications

Easy to install

- Pre-assembled gearmotor packages eliminate motor assembly
- Factory-filled and suitable for all mounting positions, resulting in no on-site oil level adjustments
- Easy to install shaft covers, available in standard or metal detectable

Easy to maintain

- Maintenance-free design reduces contact with equipment and protects workers.
- Harsh duty sealing system with IP69 rating (for water) extends life in severe washdown applications
- Smart sensor availability allows for remote monitoring from a safe location.

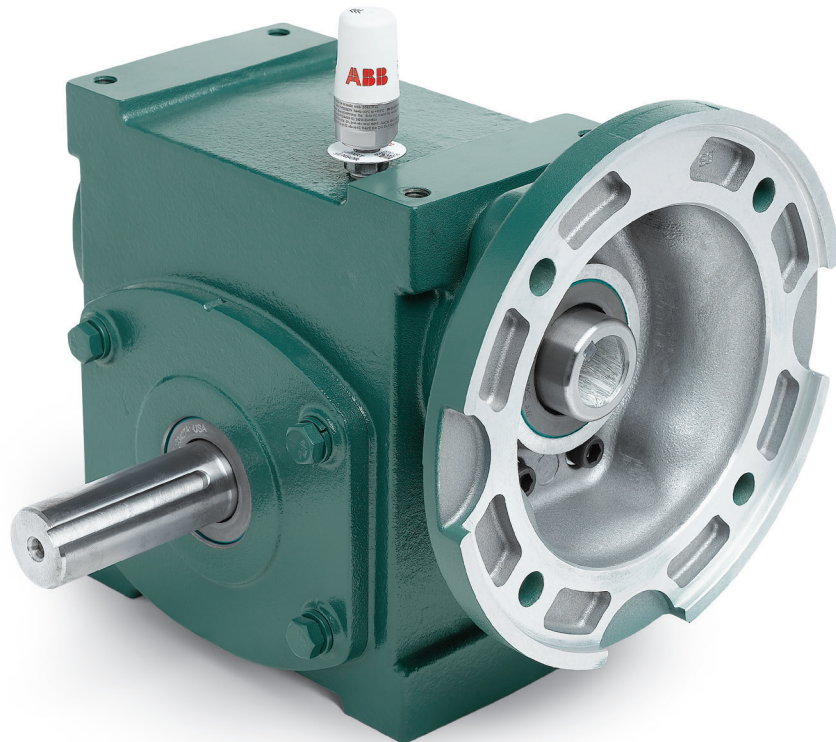

Washdown applications

Food safety and reliability

Consumers and stringent health regulations increasingly challenge food manufacturers to guarantee higher food safety and hygiene standards. However, harsh chemicals and high-pressure sprays used in clean-in-place (CIP) procedures can quickly deteriorate product reliability. Having the right processes in place and equipment that is designed around food safety principles is critical. Dodge Tigeer-2 washdown gear reducers are designed to perform reliably in the toughest washdown applications.

IP69 rated for extended life

Products rated for IP69 (for water) are protected against high temperature, high pressure spray at close proximity. Industry guidelines recommend limiting cleaning pressures to 200 psi to prevent atomizing bacteria, our testing is conducted at 7 times this pressure to demonstrate the robustness of our sealing system. To meet the IP69 rating (for water), a reducer cannot allow any water past the seal under the extreme test parameters outlined below.

IP69 test procedures

- High pressure (1,450 psi)
- High temperature (185F)
- Close range (4-6 inches)



Backed by an unprecedented 1-year warranty against failure due to water ingress

We are confident in our testing and simulations of real life clean-in-place procedures and have backed washdown Tigeer-2 reducers with an unprecedented 1-year warranty against failures due to water ingress. Unlike traditional warranties that only cover materials and workmanship, washdown Tigeer-2 reducers carry a 1-year warranty when products are registered upon installation.



Two-piece harsh duty sealing system

Protects against high-pressure sprays and sanitizing solutions in harsh washdown applications.

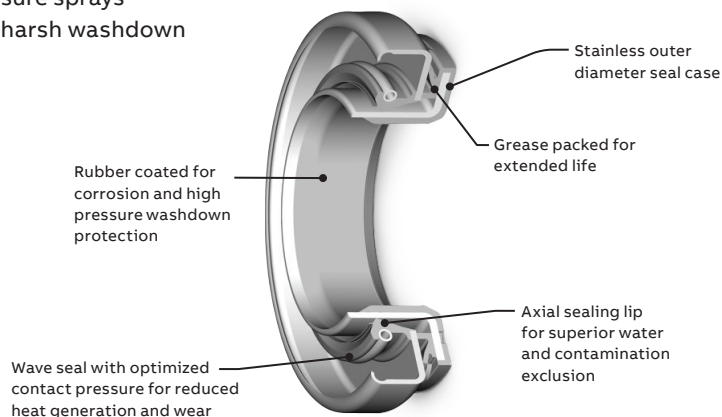

Food Safe

Tigear-2 stainless steel reducer

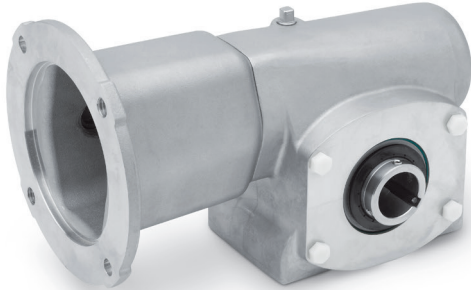

Food Safe Tigear-2 reducer

The Food Safe Tigear-2 reducer is the new standard in washdown gearing. A smooth, rounded design and laser marked nameplate reduce potential harboring or pooling locations.

Food Safe ready

- One year water ingress warranty
- IP69 rated for extended life
- Two-piece harsh duty sealing system keeps water and contaminants out and stands up to regular clean in place operations.
- All exposed surfaces are stainless steel to ensure corrosion resistance.
- Comes factory filled with food grade synthetic lube and is designed to be maintenance free.
- Center distances: 1.75", 2.00", 2.31", 2.62", and 3.00"
- Torque up to 2,400 lb.-in.
- Ratios from 5 to 60:1

Stainless steel accessories include:

- Mounting base kit
- Output flange kit
- Torque-Arm kit
- Bushing kits
- Metal detectable end covers

E-Z Kleen

Tigear-2 reducer

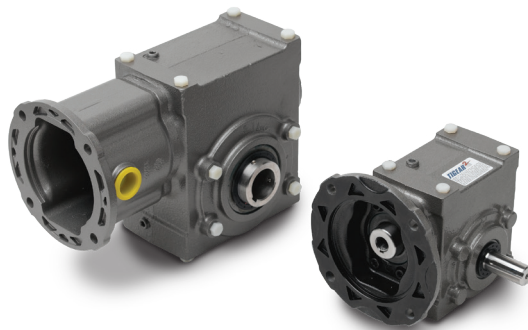

E-Z Kleen reducers are washdown ready and corrosion resistant. The totally enclosed ventless sealing system contains a factory-filled food grade synthetic lubricant that eliminates the need for routine oil changes.

Washdown ready:

- One year water ingress warranty
- IP69 rated for extended life
- Two-piece harsh duty output seals
- Tough three layer coating system has been salt fog tested to ASTM117, USDA approved for use in food applications
- 300 series stainless steel solid and hollow output shafts and stainless hardware
- Food grade lube
- Offered in sizes 13 through 35 in quill and 3-piece coupled input
- Torque up to 3,700 lb.-in.

Washdown accessories include:

- Metal detectable end covers
- Bolt-on base
- Riser block kit
- J-mount kit
- Output flange kit
- Torque-Arm kits
- Bushing kits



Dodge Industrial, Inc.

1061 Holland Road, Simpsonville, SC 29681

+1 864 297 4800

dodgeindustrial.com

Dodge Industrial, Inc. reserves all rights in this document and in the subject matter and illustrations contained therein. We reserve the right to modify contents without prior notice and do not accept responsibility for potential errors or possible lack of information in this document. Any reproduction, disclosure to third parties or utilization of its contents—in whole or in parts—is forbidden without prior written consent of Dodge Industrial, Inc.

© Copyright Dodge Industrial, Inc. All rights reserved. Specifications subject to change without notice.
An RBC Bearings company.